



OM-237519G

2019-03

Processes

Induction Heating

Description

Induction Heating Pipe Blanket

Flexible Induction Blanket

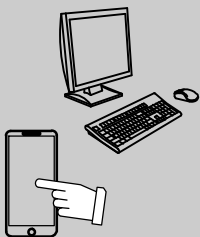
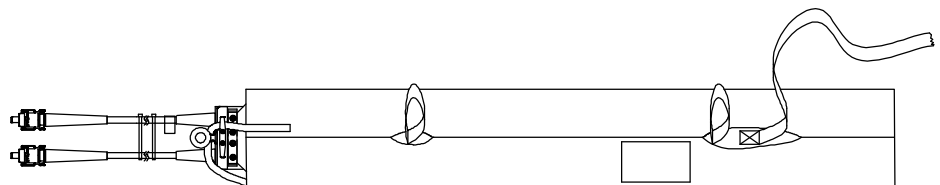

For product information,
Owner's Manual translations,
and more, visit

www.MillerWelds.com

OWNER'S MANUAL

From Miller to You

Thank you and congratulations on choosing Miller. Now you can get the job done and get it done right. We know you don't have time to do it any other way.

That's why when Niels Miller first started building arc welders in 1929, he made sure his products offered long-lasting value and superior quality. Like you, his customers couldn't afford anything less. Miller products had to be more than the best they could be. They had to be the best you could buy.

Today, the people that build and sell Miller products continue the tradition. They're just as committed to providing equipment and service that meets the high standards of quality and value established in 1929.

This Owner's Manual is designed to help you get the most out of your Miller products. Please take time to read the Safety Precautions. They will help you protect yourself against potential hazards on the worksite.



ISO 9001
Quality

Miller is the first welding equipment manufacturer in the U.S.A. to be registered to the ISO 9001 Quality System Standard.

We've made installation and operation quick and easy. With Miller, you can count on years of reliable service with proper maintenance. And if for some reason the unit needs repair, there's a Troubleshooting section that will help you figure out what the problem is, and our extensive service network is there to help fix the problem. Warranty and maintenance information for your particular model are also provided.



Miller Electric manufactures a full line of welders and welding-related equipment. For information on other quality Miller products, contact your local Miller distributor to receive the latest full line catalog or individual specification sheets. **To locate your nearest distributor or service agency call 1-800-4-A-Miller, or visit us at www.MillerWelds.com on the web.**



Working as hard as you do – every power source from Miller is backed by the most hassle-free warranty in the business.



TABLE OF CONTENTS

SECTION 1 – SAFETY PRECAUTIONS – READ BEFORE USING	1
1-1. Symbol Usage	1
1-2. Induction Heating Hazards	1
1-3. Additional Symbols for Installation, Operation, and Maintenance	2
1-4. California Proposition 65 Warnings	3
1-5. Principal Safety Standards	3
1-6. EMF Information	3
SECTION 2 – CONSIGNES DE SÉCURITÉ – LIRE AVANT UTILISATION	4
2-1. Signification des symboles	4
2-2. Dangers relatifs au soudage à l'arc	4
2-3. Dangers supplémentaires en relation avec l'installation, le fonctionnement et la maintenance	5
2-4. Proposition californienne 65 Avertissements	6
2-5. Principales normes de sécurité	6
2-6. Informations relatives aux CEM	6
SECTION 3 – SPECIFICATIONS	7
3-1. Specifications	7
SECTION 4 – INSTALLATION	8
4-1. Installation And Removal Of Replacement Induction Blanket Sleeve	8
4-2. Installation Of Replacement Induction Blanket Sleeve (Continued)	9
4-3. Connecting Blanket To Extension Cable Connectors	10
4-4. Installing Blanket On Flat Applications	11
4-5. Installing Blanket Around Pipe	12
SECTION 5 – OPERATION	13
5-1. Operating Procedure	13
5-2. Duty Cycle For Air-Cooled Blankets	13
SECTION 6 – MAINTENANCE	18
6-1. Precautionary Labels	18
SECTION 7 – STORAGE AND HANDLING	19
7-1. Storage And Handling	19
SECTION 8 – PARTS LIST	20
WARRANTY	
COMPLETE PARTS LIST – Available at www.MillerWelds.com	

SECTION 1 – SAFETY PRECAUTIONS – READ BEFORE USING

ihom_2018-01

⚠ Protect yourself and others from injury — read, follow, and save these important safety precautions and operating instructions.

1-1. Symbol Usage



DANGER! – Indicates a hazardous situation which, if not avoided, will result in death or serious injury. The possible hazards are shown in the adjoining symbols or explained in the text.



Indicates a hazardous situation which, if not avoided, could result in death or serious injury. The possible hazards are shown in the adjoining symbols or explained in the text.

NOTICE – Indicates statements not related to personal injury.

 Indicates special instructions.



This group of symbols means Warning! Watch Out! ELECTRIC SHOCK, MOVING PARTS, and HOT PARTS hazards. Consult symbols and related instructions below for necessary actions to avoid the hazards.

1-2. Induction Heating Hazards



The symbols shown below are used throughout this manual to call attention to and identify possible hazards. When you see the symbol, watch out, and follow the related instructions to avoid the hazard. The safety information given below is only a summary of the more complete safety information found in the Safety Standards listed in Section 1-5. Read and follow all Safety Standards.



Only qualified persons should install, operate, maintain, and repair this equipment. A qualified person is defined as one who, by possession of a recognized degree, certificate, or professional standing, or who by extensive knowledge, training and experience, has successfully demonstrated ability to solve or resolve problems relating to the subject matter, the work, or the project and has received safety training to recognize and avoid the hazards involved.



During operation, keep everybody, especially children, away.



ELECTRIC SHOCK can kill.

Touching live electrical parts can cause fatal shocks or severe burns. The power circuit and output bus bars or connections are electrically live whenever the output is on. The input power circuit and machine internal circuits are also live when power is on. Incorrectly installed or improperly grounded equipment is a hazard.

- Do not touch live electrical parts.
- Enclose any connecting bus bars and coolant fittings to prevent unintentional contact.
- Wear dry, hole-free insulating gloves and body protection.
- Insulate yourself from work and ground using dry insulating mats or covers big enough to prevent any physical contact with the work or ground.
- Additional safety precautions are required when any of the following electrically hazardous conditions are present: in damp locations or while wearing wet clothing; on metal structures such as floors, gratings, or scaffolds; when in cramped positions such as sitting, kneeling, or lying; or when there is a high risk of unavoidable or accidental contact with the workpiece or ground. For these conditions, see ANSI Z49.1 listed in Safety Standards. And, do not work alone!
- Disconnect input power before installing or servicing this equipment. Lockout/tagout input power according to OSHA 29 CFR 1910.147 (see Safety Standards).
- Use only nonconductive coolant hoses with a minimum length of 18 inches (457 mm) to provide isolation.
- Properly install, ground, and operate this equipment according to its Owner's Manual and national, state, and local codes.
- Always verify the supply ground – check and be sure that input power cord ground wire is properly connected to ground terminal in disconnect box or that cord plug is connected to a properly grounded receptacle outlet.

- When making input connections, attach proper grounding conductor first – double-check connections.
- Keep cords dry, free of oil and grease, and protected from hot metal and sparks.
- Frequently inspect input power cord and ground conductor for damage or bare wiring – replace immediately if damaged – bare wiring can kill.
- Turn off all equipment when not in use.
- Do not use worn, damaged, undersized, or repaired cables.
- Do not drape cables over your body.
- Do not touch power circuit if you are in contact with the work, ground, or another power circuit from a different machine.
- Use only well-maintained equipment. Repair or replace damaged parts at once. Maintain unit according to manual.
- Wear a safety harness if working above floor level.
- Keep all panels and covers securely in place.
- Use GFCI protection when operating auxiliary equipment in damp or wet locations.

SIGNIFICANT DC VOLTAGE exists in inverter power sources AFTER removal of input power.

- Turn off unit, disconnect input power, and discharge input capacitors according to instructions in Manual before touching any parts.

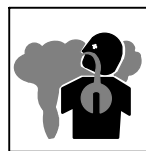

FUMES AND GASES can be hazardous.

Induction Heating of certain materials, adhesives, and fluxes can produce fumes and gases. Breathing these fumes and gases can be hazardous to your health.

- Keep your head out of the fumes. Do not breathe the fumes.
- Ventilate the work area and/or use local forced ventilation at the arc to remove welding fumes and gases. The recommended way to determine adequate ventilation is to sample for the composition and quantity of fumes and gases to which personnel are exposed.
- If ventilation is poor, wear an approved air-supplied respirator.
- Read and understand the Safety Data Sheets (SDSs) and the manufacturer's instructions for adhesives, coatings, cleaners, consumables, coolants, degreasers, fluxes, and metals.
- Work in a confined space only if it is well ventilated, or while wearing an air-supplied respirator. Always have a trained watchperson nearby. Fumes and gases from heating can displace air and lower the oxygen level causing injury or death. Be sure the breathing air is safe.
- Do not heat in locations near degreasing, cleaning, or spraying operations. The heat can react with vapors to form highly toxic and irritating gases.
- Do not overheat coated metals, such as galvanized, lead, or cadmium plated steel, unless the coating is removed from the heated area, the area is well ventilated, and while wearing an air-supplied respirator. The coatings and any metals containing these elements can give off toxic fumes if overheated. See coating SDS for temperature information.



FIRE OR EXPLOSION hazard.

- Do not overheat parts.
- Watch for fire; keep extinguisher nearby.
- Keep flammables away from work area.
- Do not locate unit on, over, or near combustible surfaces.
- Do not install unit near flammables.
- Do not cover an air-cooled blanket with any material that will cause the blanket to overheat.
- Do not operate where the atmosphere can contain flammable dust, gas, or liquid vapors (such as gasoline).
- After completion of work, inspect area to ensure it is free of sparks, glowing embers, and flames.
- Use only correct fuses or circuit breakers. Do not oversize or bypass them.
- Read and understand the Safety Data Sheets (SDSs) and the manufacturer's instructions for adhesives, coatings, cleaners, consumables, coolants, degreasers, fluxes, and metals.
- Wear body protection made from durable, flame-resistant material (leather, heavy cotton, wool). Body protection includes oil-free clothing such as leather gloves, heavy shirt, cuffless trousers, high shoes, and a cap.

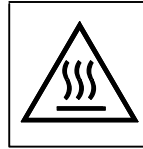

INDUCTION HEATING can burn.

- Do not touch hot parts bare-handed.
- Allow cooling period before handling parts or equipment.
- Do not touch or handle induction head/coil during operation unless the equipment is designed and intended to be used in this manner as specified in the owner's manual.
- Keep metal jewelry and other metal personal items away from head/coil during operation.
- To handle hot parts, use proper tools and/or wear heavy, insulated welding gloves and clothing to prevent burns.

1-3. Additional Symbols for Installation, Operation, and Maintenance



FALLING EQUIPMENT can injure.

- Use handle and have person of adequate physical strength lift unit.
- Move unit with hand cart or similar device.
- For units without a handle, use correct procedures and equipment of adequate capacity to lift and support unit.
- Keep equipment (cables and cords) away from moving vehicles when working from an aerial location.
- If using lift forks to move unit, be sure forks are long enough to extend beyond opposite side of unit.
- Follow the guidelines in the Applications Manual for the Revised NIOSH Lifting Equation (Publication No. 94-110) when manually lifting heavy parts or equipment.



STEAM AND HOT COOLANT can burn.

Hose may rupture if coolant overheats.

- Never disconnect both ends of hose when installed on hot workpiece.
- If coolant flow stops, leave one end of hose connected to allow coolant to return to cooler and relieve pressure.
- Remove hose from hot workpiece to prevent damage.
- Visually inspect condition of hoses, cords, and cables before each use. Do not use damaged hoses, cords, or cables.
- Allow cooling period before working on equipment.

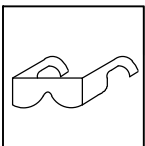

FLYING METAL OR DIRT can injure eyes.

- Wear approved safety glasses with side shields or wear face shield.



HIGH PRESSURE FLUIDS can injure or kill.

- Coolant can be under high pressure.
- Release pressure before working on cooler.
- If ANY fluid is injected into the skin or body seek medical help immediately.



MOVING PARTS can injure.

- Keep away from moving parts such as fans.
- Keep all doors, panels, covers, and guards closed and securely in place.
- Have only qualified persons remove doors, panels, covers, or guards for maintenance and troubleshooting as necessary.
- Reinstall doors, panels, covers, or guards when maintenance is finished and before reconnecting input power.

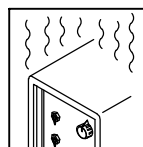

OVERUSE can cause OVERHEATING

- Allow cooling period.
- Reduce output or reduce duty cycle before starting to heat again.
- Follow rated duty cycle.

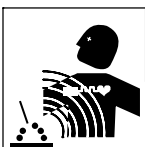

ELECTRIC AND MAGNETIC FIELDS (EMF) can affect Implanted Medical Devices.

- Wearers of Pacemakers and other Implanted Medical Devices should keep away.
- Implanted Medical Device wearers should consult their doctor and the device manufacturer before going near arc welding, spot welding, gouging, plasma arc cutting, or induction heating operations.

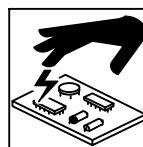

STATIC (ESD) can damage PC boards.

- Put on grounded wrist strap BEFORE handling boards or parts.
- Use proper static-proof bags and boxes to store, move, or ship PC boards.

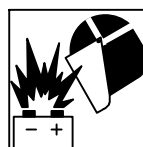

BATTERY EXPLOSION can injure.

- Do not use induction equipment to charge batteries or jump start vehicles unless it has a battery charging feature designed for this purpose.



H.F. RADIATION can cause interference.

- High-frequency (H.F.) can interfere with radio navigation, safety services, computers, and communications equipment.
- Have only qualified person familiar with electronic equipment perform this installation.
- The user is responsible for having a qualified electrician promptly correct any interference problem resulting from the installation.
- If notified by the FCC about interference, stop using the equipment at once.
- Have the installation regularly checked and maintained.
- Keep high-frequency source doors and panels tightly shut.

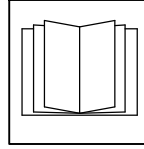

READ INSTRUCTIONS.

- Read and follow all labels and the Owner's Manual carefully before installing, operating, or servicing unit. Read the safety information at the beginning of the manual and in each section.
- Use only genuine replacement parts from the manufacturer.
- Perform installation, maintenance, and service according to the Owner's Manuals, industry standards, and national, state, and local codes.

1-4. California Proposition 65 Warnings

⚠ WARNING: This product can expose you to chemicals including lead, which are known to the state of California to cause cancer and birth defects or other reproductive harm.

For more information, go to www.P65Warnings.ca.gov.

1-5. Principal Safety Standards

Safety in Welding, Cutting, and Allied Processes, ANSI Standard Z49.1, is available as a free download from the American Welding Society at <http://www.aws.org> or purchased from Global Engineering Documents (phone: 1-877-413-5184, website: www.global.ihs.com).

Safety in Welding, Cutting, and Allied Processes, CSA Standard W117.2, from Canadian Standards Association, Standards Sales, 5060 Spectrum Way, Suite 100, Mississauga, Ontario, Canada L4W 5N5 (phone: 800-463-6727, website: www.csa-international.org).

OSHA, Occupational Safety and Health Standards for General Industry, Title 29, Code of Federal Regulations (CFR), Part 1910.177 Subpart N, Part 1910 Subpart Q, and Part 1926, Subpart J, from U.S. Government Printing Office, Superintendent of Documents, P.O. Box 371954, Pittsburgh, PA 15250-7954 (phone: 1-866-512-1800) (there are 10 OSHA Regional Offices—phone for Region 5, Chicago, is 312-353-2220, website: www.osha.gov).

National Electrical Code, NFPA Standard 70, from National Fire Protection Association, Quincy, MA 02169 (phone: 1-800-344-3555, website: www.nfpa.org and www.sparky.org).

Canadian Electrical Code Part 1, CSA Standard C22.1, from Canadian Standards Association, Standards Sales, 5060 Spectrum Way, Suite 100, Mississauga, Ontario, Canada L4W 5N5 (phone: 800-463-6727, website: www.csagroup.org).

Safe Practice For Occupational And Educational Eye And Face Protection, ANSI Standard Z87.1, from American National Standards Institute, 25 West 43rd Street, New York, NY 10036 (phone: 212-642-4900, website: www.ansi.org).

Applications Manual for the Revised NIOSH Lifting Equation, The National Institute for Occupational Safety and Health (NIOSH), 1600 Clifton Rd, Atlanta, GA 30329-4027 (phone: 1-800-232-4636, website: www.cdc.gov/NIOSH).

1-6. EMF Information

Electric current flowing through any conductor causes localized electric and magnetic fields (EMF). The current from arc welding (and allied processes including spot welding, gouging, plasma arc cutting, and induction heating operations) creates an EMF field around the welding circuit. EMF fields can interfere with some medical implants, e.g. pacemakers. Protective measures for persons wearing medical implants have to be taken. For example, restrict access for passers-by or conduct individual risk assessment for welders. All welders should use the following procedures in order to minimize exposure to EMF fields from the welding circuit:

1. Keep cables close together by twisting or taping them, or using a cable cover.
2. Do not place your body between welding cables. Arrange cables to one side and away from the operator.
3. Do not coil or drape cables around your body.

4. Keep head and trunk as far away from the equipment in the welding circuit as possible.
5. Connect work clamp to workpiece as close to the weld as possible.
6. Do not work next to, sit or lean on the welding power source.
7. Do not weld whilst carrying the welding power source or wire feeder.

About Implanted Medical Devices:

Implanted Medical Device wearers should consult their doctor and the device manufacturer before performing or going near arc welding, spot welding, gouging, plasma arc cutting, or induction heating operations. If cleared by your doctor, then following the above procedures is recommended.

SECTION 2 – CONSIGNES DE SÉCURITÉ – LIRE AVANT UTILISATION

ihom_2018-01_fre

⚠ Pour écarter les risques de blessure pour vous-même et pour autrui — lire, appliquer et ranger en lieu sûr ces consignes relatives aux précautions de sécurité et au mode opératoire.

2-1. Signification des symboles



DANGER! – Indique une situation dangereuse qui si on l'évite pas peut donner la mort ou des blessures graves. Les dangers possibles sont montrés par les symboles joints ou sont expliqués dans le texte.



Indique une situation dangereuse qui si on l'évite pas peut donner la mort ou des blessures graves. Les dangers possibles sont montrés par les symboles joints ou sont expliqués dans le texte.

AVIS – Indique des déclarations pas en relation avec des blessures personnelles.

2-2. Dangers relatifs au soudage à l'arc



Les symboles présentés ci-après sont utilisés tout au long du présent manuel pour attirer votre attention et identifier les risques de danger. Lorsque vous voyez un symbole, soyez vigilant et suivez les directives mentionnées afin d'éviter tout danger. Les consignes de sécurité présentées ci-après ne font que résumer l'information contenue dans les normes de sécurité énumérées à la section 2-5. Veuillez lire et respecter toutes ces normes de sécurité.



L'installation, l'utilisation, l'entretien et les réparations ne doivent être confiés qu'à des personnes qualifiées. Une personne qualifiée est définie comme celle qui, par la possession d'un diplôme reconnu, d'un certificat ou d'un statut professionnel, ou qui, par une connaissance, une formation et une expérience approfondies, a démontré avec succès sa capacité à résoudre les problèmes liés à la tâche, le travail ou le projet et a reçu une formation en sécurité afin de reconnaître et d'éviter les risques inhérents.



Au cours de l'utilisation, tenir toute personne à l'écart et plus particulièrement les enfants.



UNE DÉCHARGE ÉLECTRIQUE peut entraîner la mort.

Le contact de composants électriques peut provoquer des accidents mortels ou des brûlures graves. Le circuit électrique et les barres collectrices ou les connexions de sortie sont sous tension lorsque l'appareil fonctionne. Le circuit d'alimentation et les circuits internes de la machine sont également sous tension lorsque l'alimentation est sur marche. Des équipements installés ou reliés à la borne de terre de manière incorrecte sont dangereux.

- Ne pas toucher aux pièces électriques sous tension.
- Protéger toutes les barres collectrices et les raccords de refroidissement pour éviter de les toucher par inadvertance.
- Porter des gants isolants et des vêtements de protection secs et sans trous.
- S'isoler de la pièce à couper et du sol en utilisant des housses ou des tapis assez grands afin d'éviter tout contact physique avec la pièce à couper ou le sol.
- D'autres consignes de sécurité sont nécessaires dans les conditions suivantes : risques électriques dans un environnement humide ou si l'on porte des vêtements mouillés ; sur des structures métalliques telles que sols, grilles ou échafaudages ; en position coincée comme assise, à genoux ou couchée ; ou si l'y a un risque élevé de contact inévitable ou accidentel avec la pièce à souder ou le sol. Dans ces conditions, voir ANSI Z49.1 énuméré dans les normes de sécurité. En outre, ne pas travailler seul !
- Couper l'alimentation d'entrée avant d'installer l'appareil ou d'effectuer l'entretien. Verrouiller ou étiqueter la sortie d'alimentation selon la norme OSHA 29 CFR 1910.147 (se reporter aux Principales normes de sécurité).

 Indique des instructions spécifiques.



Ce groupe de symboles veut dire Avertissement! Attention! DANGER DE CHOC ÉLECTRIQUE, PIÈCES EN MOUVEMENT, et PIÈCES CHAUDES. Consulter les symboles et les instructions ci-dessous y afférant pour les actions nécessaires afin d'éviter le danger.

- N'utiliser que des tuyaux de refroidissement non conducteurs ayant une longueur minimale de 457 mm pour garantir l'isolation.
- Installer le poste correctement et le mettre à la terre convenablement selon les consignes du manuel de l'opérateur et les normes nationales, provinciales et locales.
- Toujours vérifier la terre du cordon d'alimentation. Vérifier et s'assurer que le fil de terre du cordon d'alimentation est bien raccordé à la borne de terre du sectionneur ou que la fiche du cordon est raccordée à une prise correctement mise à la terre.
- En effectuant les raccordements d'entrée, fixer d'abord le conducteur de mise à la terre approprié et revérifier les connexions.
- Les câbles doivent être exempts d'humidité, d'huile et de graisse; protégez-les contre les étincelles et les pièces métalliques chaudes.
- Vérifier fréquemment le cordon d'alimentation et le conducteur de mise à la terre afin de s'assurer qu'il n'est pas altéré ou dénudé. Le remplacer immédiatement s'il l'est. Un fil dénudé peut entraîner la mort.
- L'équipement doit être hors tension lorsqu'il n'est pas utilisé.
- Ne pas utiliser des câbles usés, endommagés, de grosseur insuffisante ou mal épissés.
- Ne pas enrouler les câbles autour du corps.
- Ne pas toucher le circuit électrique si l'on est en contact avec la pièce, la terre ou le circuit électrique d'une autre machine.
- N'utiliser qu'un matériel en bon état. Réparer ou remplacer sur-le-champ les pièces endommagées. Entretien l'appareil conformément à ce manuel.
- Porter un harnais de sécurité si l'on doit travailler au-dessus du sol.
- S'assurer que tous les panneaux et couvercles sont correctement en place.
- Utiliser une protection différentielle lors de l'utilisation d'un équipement auxiliaire dans des endroits humides ou mouillés.

Il reste une TENSION DC NON NÉGLIGEABLE dans les sources de soudage onduleur UNE FOIS le moteur coupé.

- Éteignez l'unité, débranchez le courant électrique, et déchargez les condensateurs d'alimentation selon les instructions indiquées dans le manuel avant de toucher les pièces.

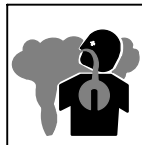

LES FUMÉES ET LES GAZ peuvent être dangereux.

Le chauffage à induction de certains matériaux, adhésifs et flux génère des fumées et des gaz. Leur inhalation peut être dangereuse pour votre santé.

- Ne pas mettre sa tête au-dessus des vapeurs. Ne pas respirer ces vapeurs.
- À l'intérieur, ventiler la zone et/ou utiliser une ventilation forcée au niveau de l'arc pour l'évacuation des fumées et des gaz de soudage. Pour déterminer la bonne ventilation, il est recommandé de procéder à un prélèvement pour la composition et la quantité de fumées et de gaz auxquelles est exposé le personnel.

- Si la ventilation est médiocre, porter un respirateur anti-vapeurs approuvé.
- Lire et comprendre les fiches de données de sécurité et les instructions du fabricant concernant les adhésifs, les revêtements, les nettoyeurs, les consommables, les produits de refroidissement, les dégraisseurs, les flux et les métaux.
- Travailler dans un espace fermé seulement s'il est bien ventilé ou en portant un respirateur. Demander toujours à un surveillant dûment formé de se tenir à proximité. Des fumées et des gaz provenant du chauffage peuvent déplacer l'air, abaisser le niveau d'oxygène et provoquer des lésions ou des accidents mortels. S'assurer que l'air ambiant ne présente aucun danger.
- Ne pas chauffer dans des endroits se trouvant à proximité d'opérations de dégraissage, de nettoyage ou de pulvérisation. La chaleur peut réagir en présence de vapeurs et former des gaz hautement toxiques et irritants.
- Ne pas surchauffer des métaux munis d'un revêtement tels que l'acier galvanisé, plaqué au plomb ou au cadmium, à moins que le revêtement ne soit enlevé de la zone chauffée, que la zone soit bien ventilée et, si nécessaire, en portant un respirateur. Les revêtements et tous les métaux contenant ces éléments peuvent dégager des fumées toxiques s'ils sont surchauffés. Voir les informations concernant la température dans les spécifications de revêtement SDS.



Risque D'INCENDIE OU D'EXPLOSION.

- Ne pas surchauffer les composants .
- Attention aux risques d'incendie: tenir un extincteur à proximité.
- Stocker des produits inflammables hors de la zone de travail.
- Ne pas placer l'appareil sur, au-dessus ou à proximité de surfaces inflammables.
- Ne pas installer l'appareil à proximité de produits inflammables.

- Ne pas couvrir les protections isolantes refroidies par air avec un matériau pouvant entraîner leur surchauffe.
- Ne pas souder là où l'air ambiant pourrait contenir des poussières, gaz ou émanations inflammables (vapeur d'essence, par exemple).
- Une fois le travail achevé, assurez-vous qu'il ne reste aucune trace d'étincelles incandescentes ni de flammes.
- Utiliser exclusivement des fusibles ou coupe-circuits appropriés. Ne pas augmenter leur puissance; ne pas les pointer.
- Lire et comprendre les fiches de données de sécurité et les instructions du fabricant concernant les adhésifs, les revêtements, les nettoyeurs, les consommables, les produits de refroidissement, les dégraisseurs, les flux et les métaux.
- Porter un équipement de protection pour le corps fait d'un matériau résistant et ignifuge (cuir, coton robuste, laine). La protection du corps comporte des vêtements sans huile comme par ex. des gants de cuir, une chemise solide, des pantalons sans revers, des chaussures hautes et une casquette.



LE CHAUFFAGE PAR INDUCTION peut provoquer des brûlures.

- Ne pas toucher des parties chaudes à mains nues.
- Laisser refroidir les composants ou équipements avant de les manipuler.
- Ne pas toucher ou manipuler les câbles/enroulements d'induction durant l'opération à moins que l'équipement soit conçu à cet effet comme indiqué dans le manuel d'utilisateur.
- Tenir les bijoux et autres objets personnels en métal éloignés de la tête/de l'enroulement pendant le fonctionnement.
- Ne pas toucher aux pièces chaudes, utiliser les outils recommandés et porter des gants de soudage et des vêtements épais pour éviter les brûlures.

2-3. Dangers supplémentaires en relation avec l'installation, le fonctionnement et la maintenance



LA CHUTE DE L'ÉQUIPEMENT peut provoquer des blessures.

- Utiliser la poignée et demander à une personne ayant la force physique nécessaire pour soulever l'appareil.
- Déplacer l'appareil à l'aide d'un chariot ou d'un engin similaire.
- Pour les unités sans poignée, utilisez les procédures correctes et un équipement de levage de capacité suffisante pour lever l'appareil.
- Tenir l'équipement (câbles et cordons) à distance des véhicules mobiles lors de toute opération en hauteur.
- En utilisant des fourches de levage pour déplacer l'unité, s'assurer que les fourches sont suffisamment longues pour dépasser du côté opposé de l'appareil.
- Suivre les consignes du Manuel des applications pour l'équation de levage NIOSH révisée (Publication N°94-110) lors du levage manuelle de pièces ou équipements lourds.

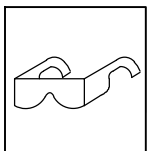

DES PIÈCES DE METAL ou DES SALETES peuvent provoquer des blessures dans les yeux.

- Porter des lunettes de sécurité à coques latérales ou un écran facial.



DES ORGANES MOBILES peuvent provoquer des blessures.

- S'abstenir de toucher des organes mobiles tels que des ventilateurs.
- Maintenir fermés et verrouillés les portes, panneaux, recouvrements et dispositifs de protection.

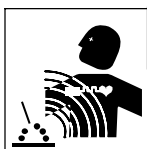

Les CHAMPS ÉLECTROMAGNÉTIQUES (CEM) peuvent affecter les implants médicaux.

- Les porteurs de stimulateurs cardiaques et autres implants médicaux doivent rester à distance.

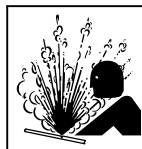

LE LIQUIDE DE REFROIDISSEMENT CHAUD ET LA VAPEUR peuvent causer des brûlures.

Si le liquide de refroidissement est en surchauffe, un boyau pourrait se sectionner.

- Ne jamais débrancher les deux extrémités du tuyau lorsque l'appareil est installé sur une pièce de travail chaude.
- Si le liquide de refroidissement cesse de s'écouler, laisser une extrémité du tuyau branchée pour permettre au liquide de refroidissement chaud de revenir au refroidisseur et dépressuriser.
- Pour éviter tout risque de dommage, retirer le tuyau de la pièce de travail chaude.
- Effectuer une inspection visuelle des boyaux, cordons et câbles avant chaque utilisation. Ne pas utiliser des boyaux, cordons ou câbles endommagés.
- Laissez refroidir avant d'intervenir sur l'équipement.



LES LIQUIDES SOUS HAUTE PRESSION peuvent provoquer des blessures ou la mort.

- Liquide de refroidissement sous haute pression.
- Libérez la pression avant d'intervenir sur le refroidisseur.
- En cas d'injection d'un liquide QUELCONQUE dans la peau ou le corps, consultez immédiatement un médecin.

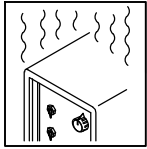

L'EMPLOI EXCESSIF peut SURCHAUFFER L'ÉQUIPEMENT.

- Prévoir une période de refroidissement
- Réduire le courant de sortie ou le facteur de marche avant de recommencer le chauffage.

- Respecter le cycle opératoire nominal.

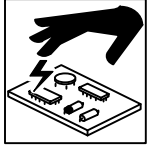

LES CHARGES ÉLECTROSTATIQUES peuvent endommager les circuits imprimés.

- Établir la connexion avec la barrette de terre AVANT de manipuler des cartes ou des pièces.

- Utiliser des pochettes et des boîtes antistatiques pour stocker, déplacer ou expédier des cartes PC.



L'EXPLOSION DE LA BATTERIE peut provoquer des blessures.

- Ne pas utiliser l'appareil de soudage pour charger des batteries ou faire démarrer des véhicules à l'aide de câbles de démarrage, sauf si l'appareil dispose d'une fonctionnalité de charge de batterie destinée à cet usage.

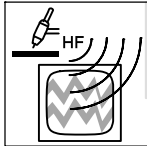

LE RAYONNEMENT HAUTE FRÉQUENCE (HF) risque de provoquer des interférences.

- Le rayonnement haute fréquence (HF) peut provoquer des interférences avec les équipements de radio-navigation et de communication, les services de sécurité et les ordinateurs.

- Demander seulement à des personnes qualifiées familiarisées avec des équipements électroniques de faire fonctionner l'installation.
- L'utilisateur est tenu de faire corriger rapidement par un électricien qualifié les interférences résultant de l'installation.
- Si le FCC signale des interférences, arrêter immédiatement l'appareil.
- Effectuer régulièrement le contrôle et l'entretien de l'installation.
- Maintenir soigneusement fermés les portes et les panneaux des sources de haute fréquence.

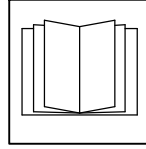

LIRE LES INSTRUCTIONS.

- Lire et appliquer les instructions sur les étiquettes et le Mode d'emploi avant l'installation, l'utilisation ou l'entretien de l'appareil. Lire les informations de sécurité au début du manuel et dans chaque section.
- N'utiliser que les pièces de rechange recommandées par le constructeur.
- Effectuer l'installation, l'entretien et toute intervention selon les manuels d'utilisateurs, les normes nationales, provinciales et de l'industrie, ainsi que les codes municipaux.

2-4. Proposition californienne 65 Avertissements

AVERTISSEMENT : ce produit peut vous exposer à des produits chimiques tels que le plomb, reconnus par l'État de Californie comme cancérigènes et sources de malformations ou d'autres troubles de la reproduction.

Pour plus d'informations, consulter www.P65Warnings.ca.gov.

2-5. Principales normes de sécurité

Safety in Welding, Cutting, and Allied Processes, ANSI Standard Z49.1, from Global Engineering Documents (phone: 1-877-413-5184, website: www.global.ihs.com).

Safety in Welding, Cutting, and Allied Processes, CSA Standard W117.2, from Canadian Standards Association, Standards Sales, 5060 Spectrum Way, Suite 100, Mississauga, Ontario, Canada L4W 5N5 (phone: 800-463-6727, website: www.csagroup.org).

OSHA, Occupational Safety and Health Standards for General Industry, Title 29, Code of Federal Regulations (CFR), Part 1910, Subpart Q, and Part 1926, Subpart J, auprès du U.S. Government Printing Office, Superintendent of Documents, P.O. Box 371954, Pittsburgh, PA 15250-7954 (téléphone : 1-866-512-1800) (il y a 10 bureaux régionaux—le téléphone de la région 5, Chicago, est 3123532220, site Internet : www.osha.gov).

National Electrical Code, NFPA Standard 70, from National Fire Protection Association, Quincy, MA 02169 (phone: 1-800-344-3555, website: www.nfpa.org and www.sparky.org).

Canadian Electrical Code Part 1, CSA Standard C22.1, from Canadian Standards Association, Standards Sales, 5060 Spectrum Way, Suite 100, Mississauga, Ontario, Canada L4W 5N5 (phone: 800-463-6727, website: www.csagroup.org).

Safe Practice For Occupational And Educational Eye And Face Protection, ANSI Standard Z87.1, from American National Standards Institute, 25 West 43rd Street, New York, NY 10036 (phone: 212-642-4900, website: www.ansi.org).

Applications Manual for the Revised NIOSH Lifting Equation, The National Institute for Occupational Safety and Health (NIOSH), 1600 Clifton Rd, Atlanta, GA 30329-4027 (phone: 1-800-232-4636, website: www.cdc.gov/NIOSH).

2-6. Informations relatives aux CEM

Le courant électrique qui traverse tout conducteur génère des champs électromagnétiques (CEM) à certains endroits. Le courant issu d'un soudage à l'arc (et de procédés connexes, y compris le soudage par points, le gougeage, le découpage plasma et les opérations de chauffage par induction) crée un champ électromagnétique (CEM) autour du circuit de soudage. Les champs électromagnétiques produits peuvent causer interférence à certains implants médicaux, p.ex. les stimulateurs cardiaques. Des mesures de protection pour les porteurs d'implants médicaux doivent être prises: Limiter par exemple tout accès aux passants ou procéder à une évaluation des risques individuels pour les soudeurs. Tous les soudeurs doivent appliquer les procédures suivantes pour minimiser l'exposition aux CEM provenant du circuit de soudage:

1. Rassembler les câbles en les torsadant ou en les attachant avec du ruban adhésif ou avec une housse.
2. Ne pas se tenir au milieu des câbles de soudage. Disposer les câbles d'un côté et à distance de l'opérateur.

3. Ne pas courber et ne pas entourer les câbles autour de votre corps.
4. Maintenir la tête et le torse aussi loin que possible du matériel du circuit de soudage.
5. Connecter la pince sur la pièce aussi près que possible de la soudure.
6. Ne pas travailler à proximité d'une source de soudage, ni s'asseoir ou se pencher dessus.
7. Ne pas souder tout en portant la source de soudage ou le dévidoir.

En ce qui concerne les implants médicaux :

Les porteurs d'implants doivent d'abord consulter leur médecin avant de s'approcher des opérations de soudage à l'arc, de soudage par points, de gougeage, du coupage plasma ou de chauffage par induction. Si le médecin approuve, il est recommandé de suivre les procédures précédentes.

SECTION 3 – SPECIFICATIONS

3-1. Specifications

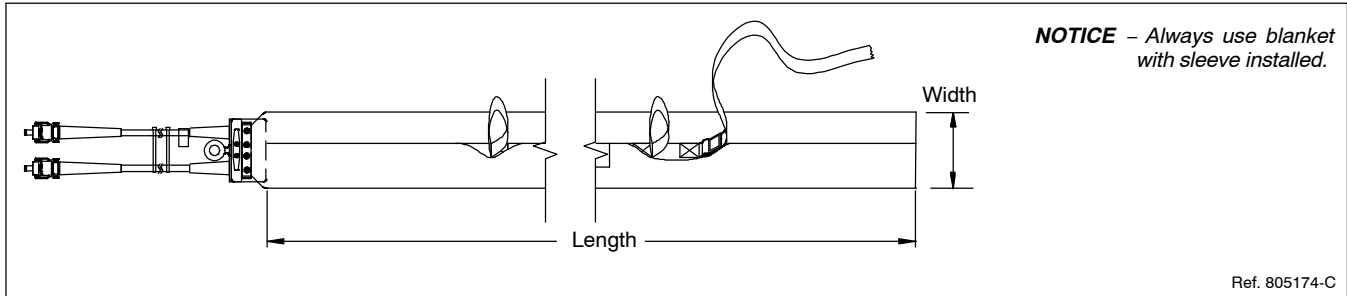

Maximum blanket preheat temperature: 400° F (204° C)

NOTICE – Blanket life will be shortened and damage will occur if exposed to temperatures above 400 °F (204 °C).

Blanket Part No.	Dimensions	Pipe Fit Diameter (w/Induction Blanket Sleeve)
300080	Length: 40 in. (1016 mm); Width: 13-7/64 in. (333 mm)	8-5/8 in. (219 mm) Dia
300079	Length: 44 in. (1118 mm); Width: 11-19/64 (490 mm)	10-3/4 in. (273 mm) Dia
300078	Length: 47 in. (1194 mm); Width: 10-7/64 (257 mm)	12 in. (305 mm) Dia
300077	Length: 53 in. (1346 mm); Width: 10-7/64 (257 mm)	14 in. (356 mm) Dia
300075	Length: 60 in. (1524 mm); Width: 10-7/64 (257 mm)	16 in. (406 mm) Dia
300074	Length: 66 in. (1676 mm); Width: 9 in. (229 mm)	18 in. (457 mm) Dia
300073	Length: 72 in. (1829 mm); Width: 9 in. (229 mm)	20 in. (508 mm) Dia
300072	Length: 78 in. (1981 mm); Width: 9 in. (229 mm)	22 in. (559 mm) Dia
300071	Length: 85 in. (2159 mm); Width: 9 in. (229 mm)	24 in. (610 mm) Dia
300070	Length: 91 in. (2311 mm); Width: 9 in. (229 mm)	26 in. (660 mm) Dia
300069	Length: 97 in. (2464 mm); Width: 9 in. (229 mm)	28 in. (711 mm) Dia
300068	Length: 104 in. (2642 mm); Width: 9 in. (229 mm)	30 in. (762 mm) Dia
300067	Length: 110 in. (2794 mm); Width: 9 in. (229 mm)	32 in. (813 mm) Dia
300066	Length: 116 in. (2946 mm); Width: 9 in. (229 mm)	34 in. (864 mm) Dia
300065	Length: 122 in. (3099 mm); Width: 7-1/2 in. (191 mm)	36 in. (914 mm) Dia
300064	Length: 129 in. (3277 mm); Width: 7-1/2 in. (191 mm)	38 in. (965 mm) Dia
300087	Length: 135 in. (3429 mm); Width: 7-1/2 in. (191 mm)	40 in. (1016 mm) Dia
300063	Length: 141 in. (3581 mm); Width: 7-1/2 in. (191 mm)	42 in. (1067 mm) Dia
300088	Length: 147 in. (3734 mm); Width: 7-1/2 in. (191 mm)	44 in. (1118 mm) Dia
300062	Length: 154 in. (3912 mm); Width: 7-1/2 in. (191 mm)	46 in. (1168 mm) Dia
300061	Length: 160 in. (4064 mm); Width: 7-1/2 in. (191 mm)	48 in. (1219 mm) Dia
300060	Length: 173 in. (4394 mm); Width: 7-1/2 in. (191 mm)	52 in. (1321 mm) Dia
244584	Length: 185 in. (4699 mm); Width: 7-1/2 in. (191 mm)	56 in. (1422 mm) Dia
300336	Length: 195 in. (4953 mm); Width: 7-1/2 in. (191 mm)	60 in. (1524 mm) Dia
301088	Length: 160 in. (4064 mm); Width: 4-1/2 in. (114 mm)	48 in. (1219 mm) Dia
301089	Length: 185 in. (4699 mm); Width: 4-1/2 in. (114 mm)	56 in. (1422 mm) Dia
301188	Length: 173 in. (4394 mm); Width: 4-1/2 in. (114 mm)	52 in. (1321 mm) Dia
301189	Length: 236 in. (5994 mm); Width: 4-1/2 in. (114 mm)	72 in. (1829 mm) Dia

SECTION 4 – INSTALLATION

4-1. Installation And Removal Of Replacement Induction Blanket Sleeve



⚠ Disconnect power to blanket before changing sleeve.

☞ Always use blanket with sleeve installed.

☞ For ease of induction blanket sleeve installation and removal, this procedure may require two people or some other means of suspending blanket by its handles.

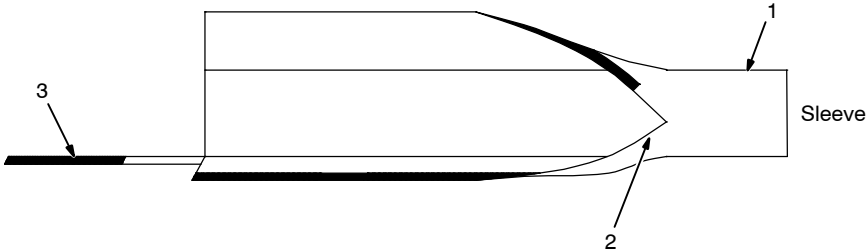

- 1 Replacement Sleeve
- 2 Slots
- 3 Sleeve Securing Strap

Remove original sleeve.

To remove sleeve, remove securing strap from around eyelet shaft.

Open hook and loop seam, and remove sleeve from blanket.

☞ Check blanket for damage before replacing sleeve. See maintenance section of Pro-Heat Flexible Induction Blanket owner's manual OM-237519.

Completely open replacement sleeve at hook and loop fastening seam.

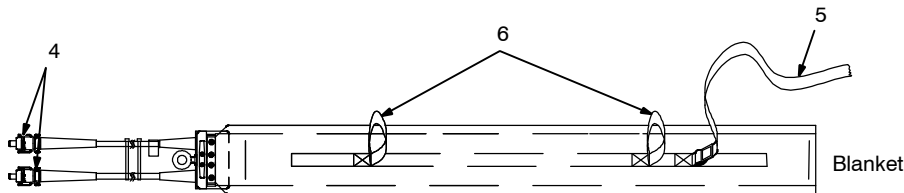

- 4 Connector end of blanket
- 5 Blanket Securing Strap
- 6 Handles
- 7 Warning Label

Insert non-connector end of blanket into bottom of sleeve.

☞ Replacement sleeve will be tight.

Keep warning label side of replacement sleeve facing the same direction as the blanket handles and securing strap.

Be sure that securing strap and blanket handles line up and extend out of slot in seam.

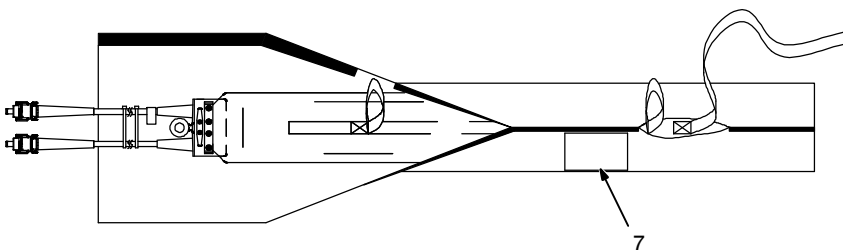

- 8 Hook And Loop Seam

Secure hook and loop seam on sleeve.

- 9 Short Strap

Install short strap with loop side of hook and loop at handle location to prevent seam from closing.

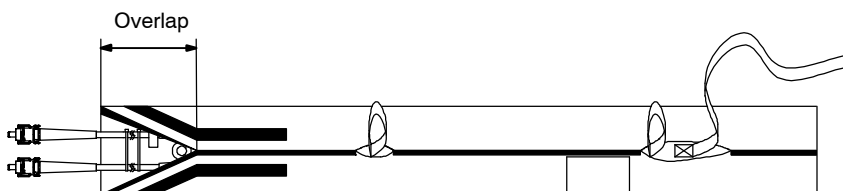
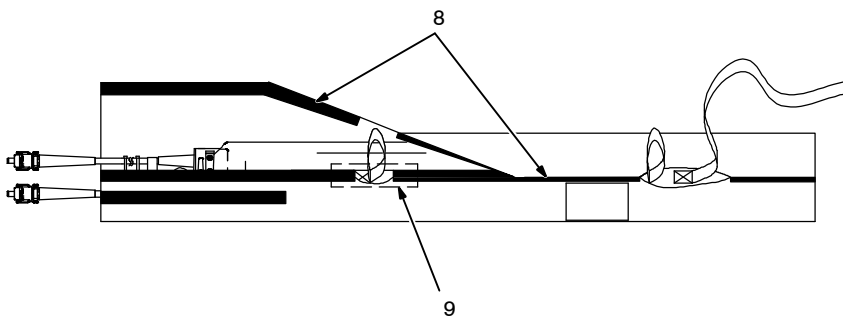

4-2. Installation Of Replacement Induction Blanket Sleeve (Continued)



⚠ Disconnect power to blanket before changing sleeve.

- 10 Red Fiberglass Plate
- 11 Blanket
- 12 Slots
- 13 Eye Bolt

For sleeves longer than the blanket, roll the end of the sleeve inwards until the opening lines up with the red wear plate as shown.

☞ Leave overlap of seam unhooked before rolling inwards to get shorter length.

On back of blanket, wedge sleeve between red fiberglass plate and blanket.

Wrap sleeve securing strap around shaft of eye bolt on blanket and use hook and loop fastener to secure sleeve to blanket.

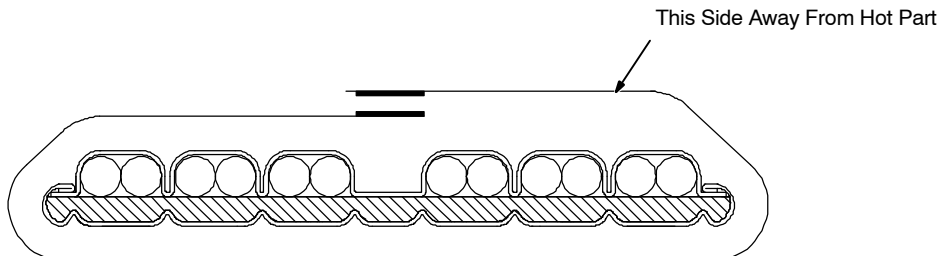
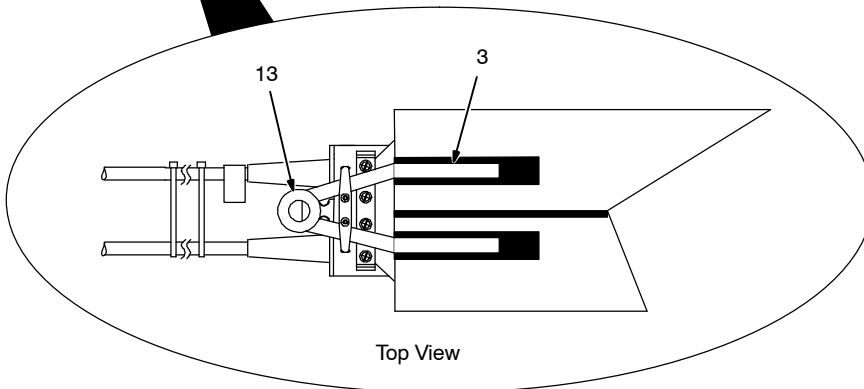
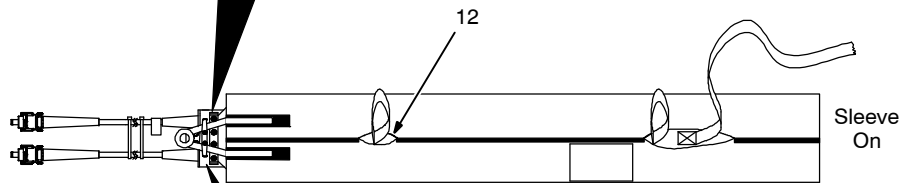
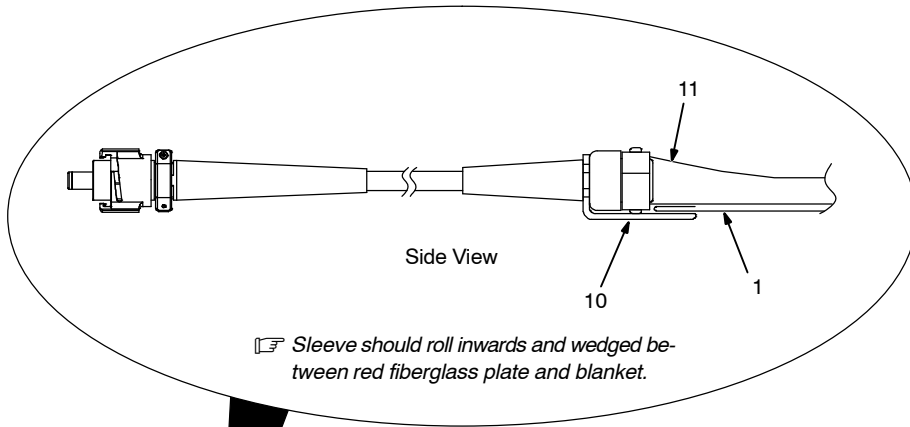

4-3. Connecting Blanket To Extension Cable Connectors

A. Standard Blanket Connections

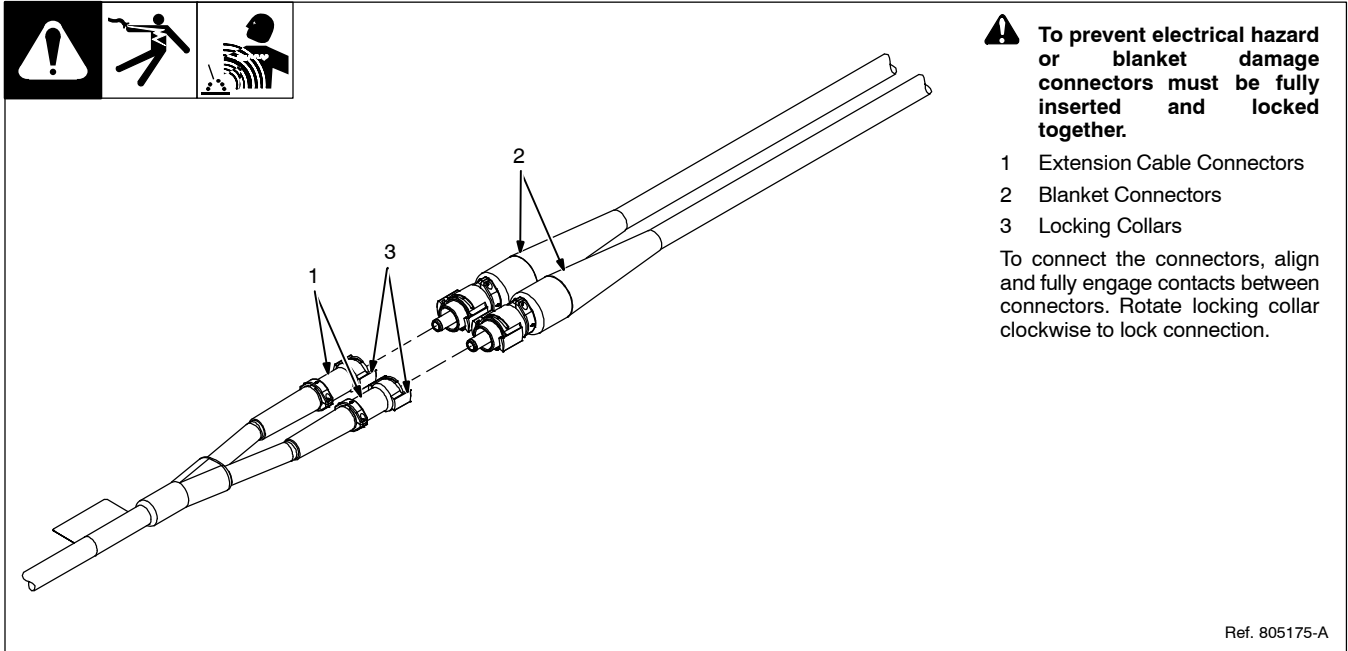

B. Narrow Blanket Connections

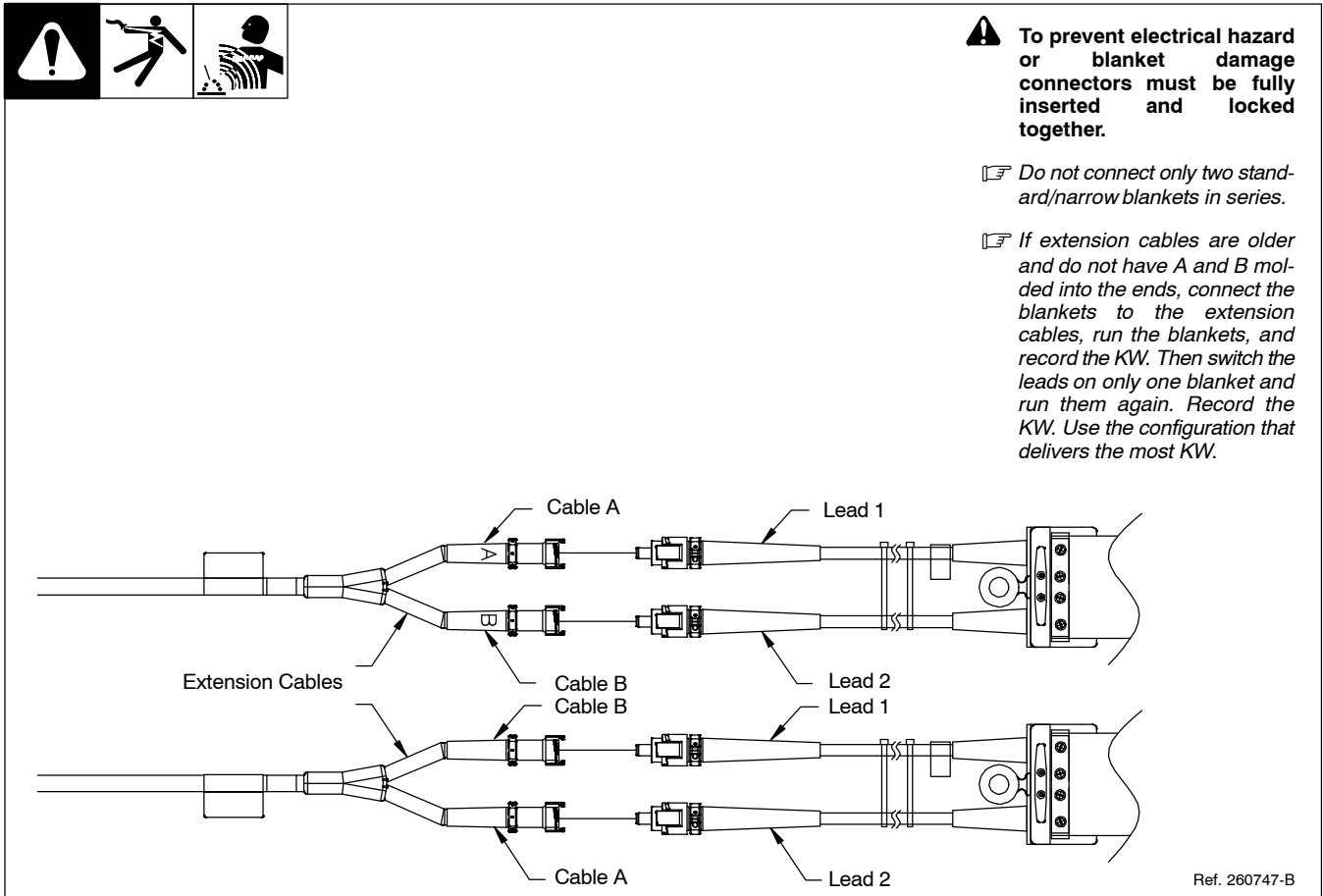

C. Four Narrow Blanket Series/Parallel Connections



⚠ To prevent electrical hazard or blanket damage connectors must be fully inserted and locked together.

⚠ Do not connect only two standard/narrow blankets in series.

⚠ If extension cables are older and do not have A and B molded into the ends, connect the blankets to the extension cables, run the blankets, and record the KW. Then switch the leads on only one blanket and run them again. Record the KW. Use the configuration that delivers the most KW.

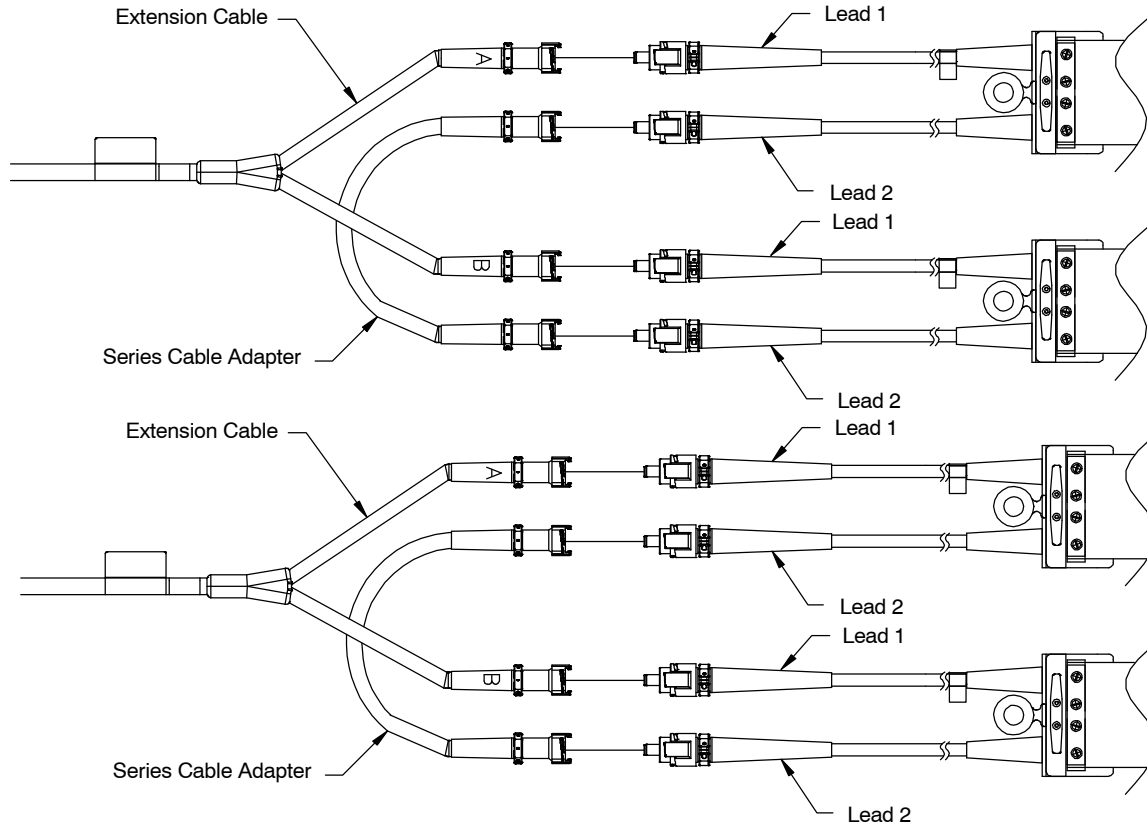

Ref. 260747-B

4-4. Installing Blanket On Flat Applications

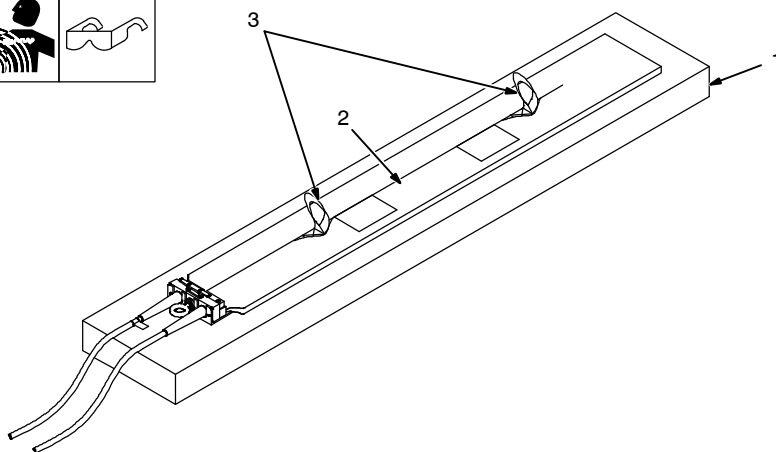

- 1 Metal Part
- 2 Induction Heating Blanket
- 3 Blanket Handles

Use handles to position blanket on part. Remove pipe securing strap (see Section 4-5, Item 5 and Figure 8-1).

⚠ For narrow blankets, place one blanket on either side of the weld seam approximately four inches apart and equally spaced from the seam.

⚠ Blanket must be in full contact with entire part surface coupled by blanket for best heating results and system performance.

Ref. 805174-C

4-5. Installing Blanket Around Pipe

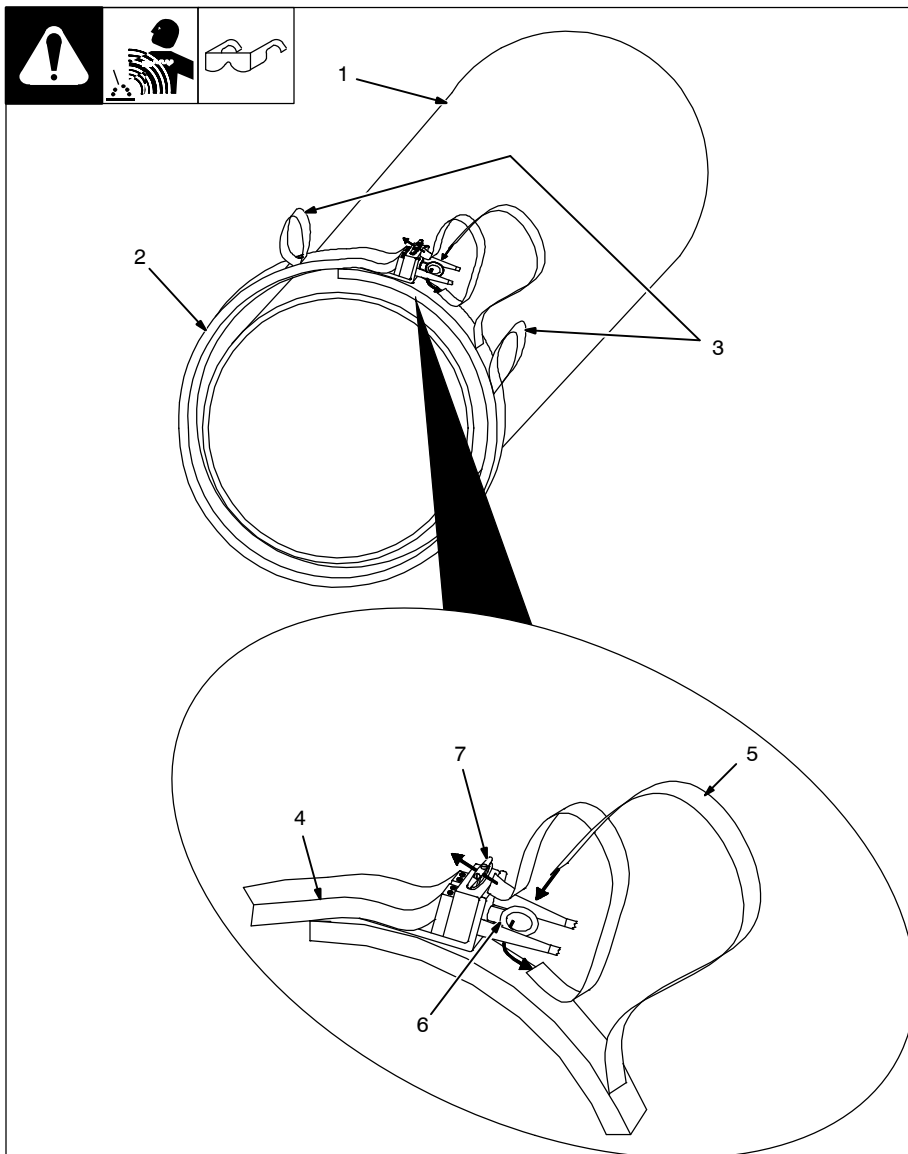

- 1 Metal Pipe
- 2 Induction Heating Blanket

Wrap blanket around pipe at the location to be heated.

- 3 Blanket Handles
- 4 Blanket Overlap

Use handles to position blanket overlap in a convenient location, usually near top of pipe.

- 5 Securing Strap
- 6 Eyelet

Route securing strap through eyelet and begin tightening blanket firmly to pipe surface.

- 7 Cleat

Routing end of securing strap through center opening of cleat will hold blanket tight while wrapping strap around cleat.

NOTICE – Blanket must be in full contact with entire circumference of pipe for best heating results and system performance.

DO NOT double wrap incorrect blanket sizes around a pipe. Each individual blanket is dedicated to a specific pipe size. Failure to comply may cause undesirable heating characteristics, and could result in damage to the blanket and void the warranty.

Cleat Hitch Knot

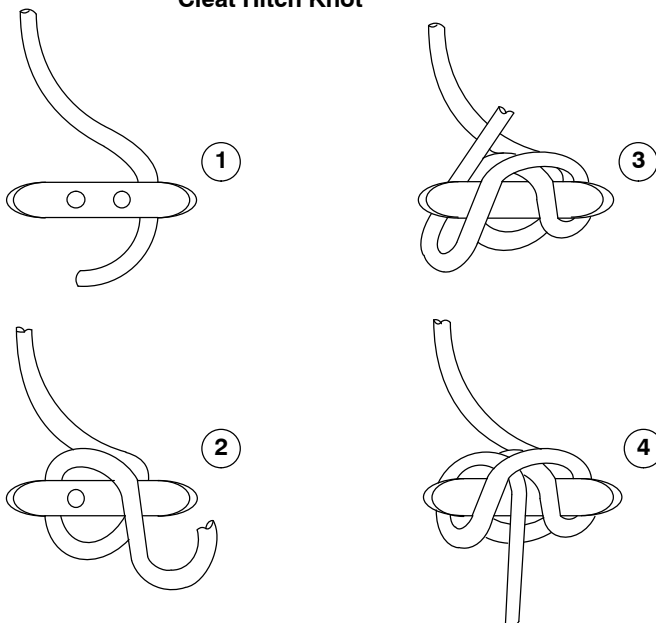

SECTION 5 – OPERATION

5-1. Operating Procedure

NOTICE – For proper safety and to prevent damage to induction heating system including blanket, turn off power source output prior to removing blanket from metal pipe or metal part.

See power source Owner's Manual for operating instructions.

5-2. Duty Cycle For Air-Cooled Blankets

The ProHeat 35 induction power source is designed to deliver full output power of 35kW at 100% duty cycle; however, the air-cooled induction blankets are NOT designed for 100% duty cycle operation at the full output power of 35kW.

Using the induction heating system with air-cooled blankets will usually be set up in one of three different configurations as follows:

Duty Cycle For Standard Air-Cooled Blankets

A. A Single Standard Blanket Connected To The Power Source

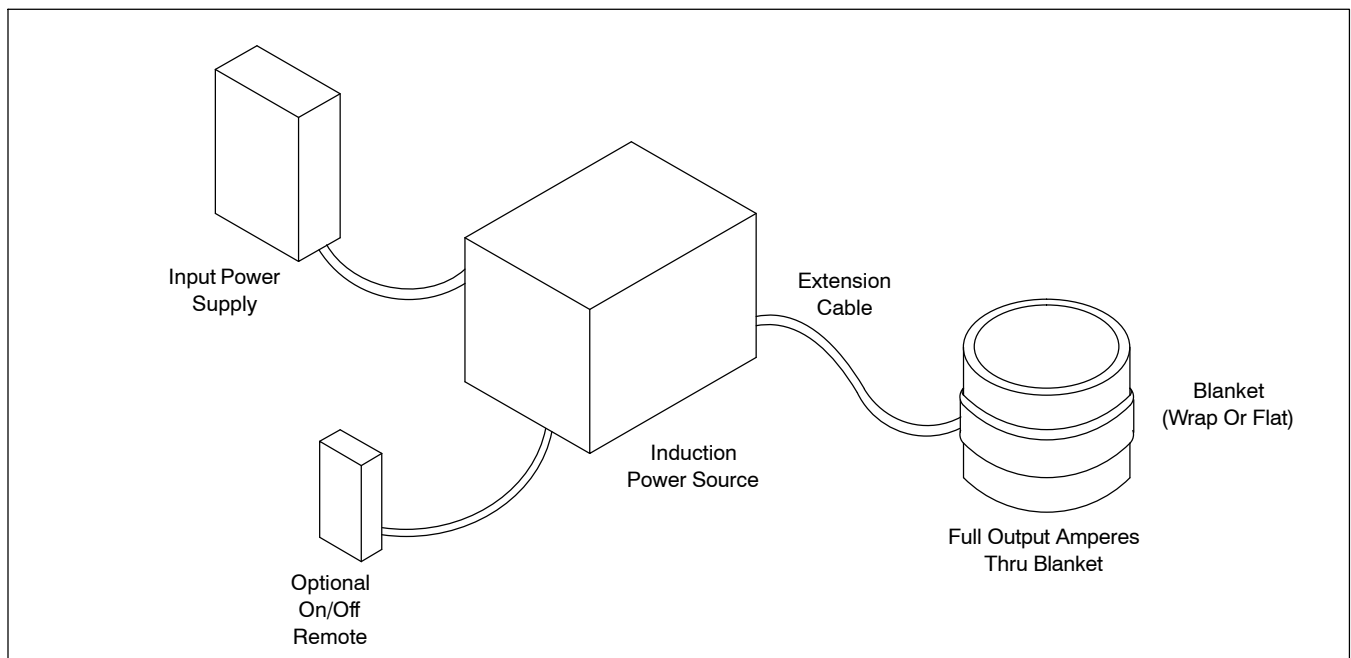

A single blanket arrangement requires a single extension cable and blanket connected to the power source. The power source will typically deliver approximately 220 to 245 amperes in this arrangement, so for short duty cycle operation (less than 15 minutes) the wire in the blanket can withstand this current level. If operating at longer duty cycles (greater than 15 minutes) the power source will reduce output power to prevent damage to the blanket.

☞ Operating current should not exceed 160 amperes when using a single blanket during a long duty cycle.

B. Two Standard Blankets Connected In Parallel To A Single Power Source

☞ Do not use two blankets connected in series to the power source.

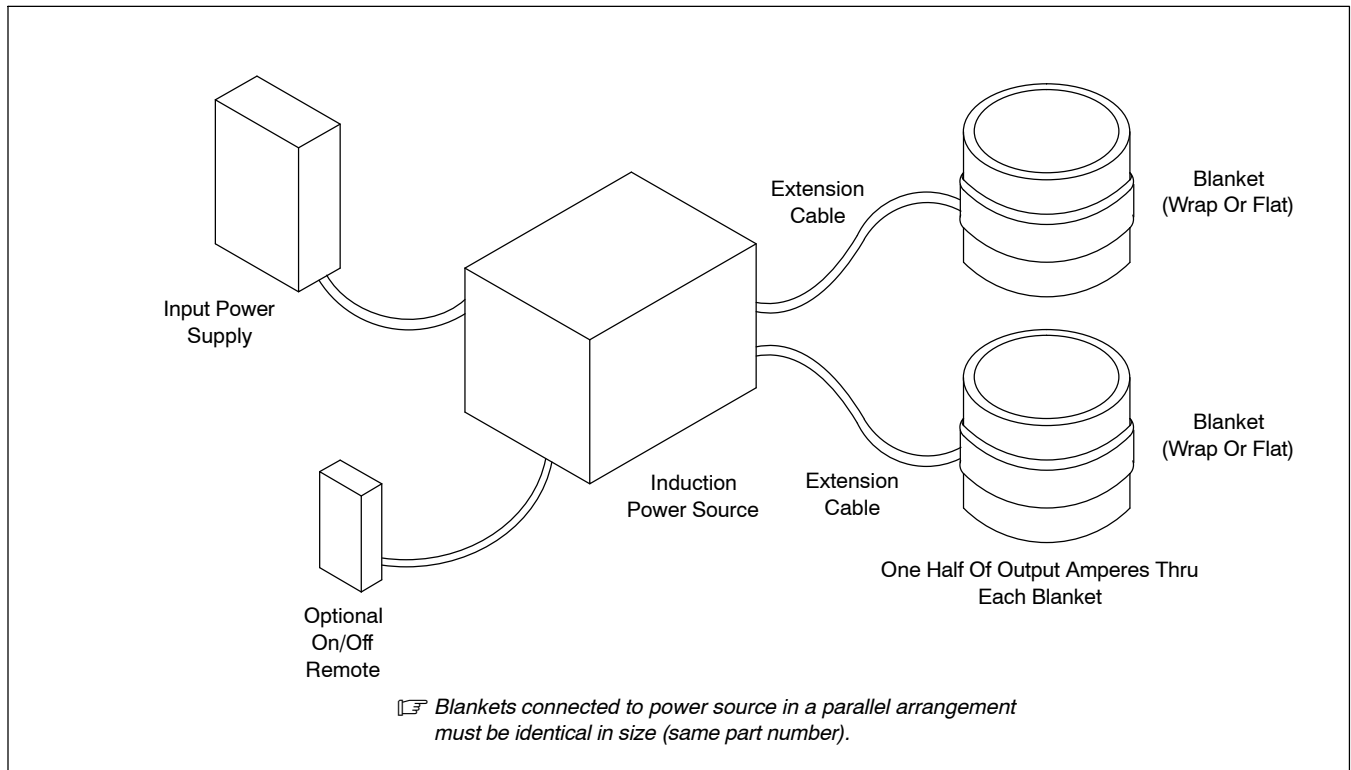

A two blanket parallel arrangement requires two equally sized blankets and two extension cables connected to a single power source. The output power from the power source will divide equally between the two blankets (assuming both blankets are in direct contact with the surface of the material to be heated). This arrangement will increase the time to reach desired heating temperature as compared to a single blanket arrangement. However, output current will increase about 40% (i.e. $224A \times 1.4 = 314A$). Current will divide equally between the blankets resulting in each blanket receiving approximately 157 amperes. Since the parallel amperage is below the 160 amperes maximum, long-term operation (100% duty cycle) is acceptable.

C. Four Standard Blankets Connected In A Series/Parallel Arrangement To A Single Power Source

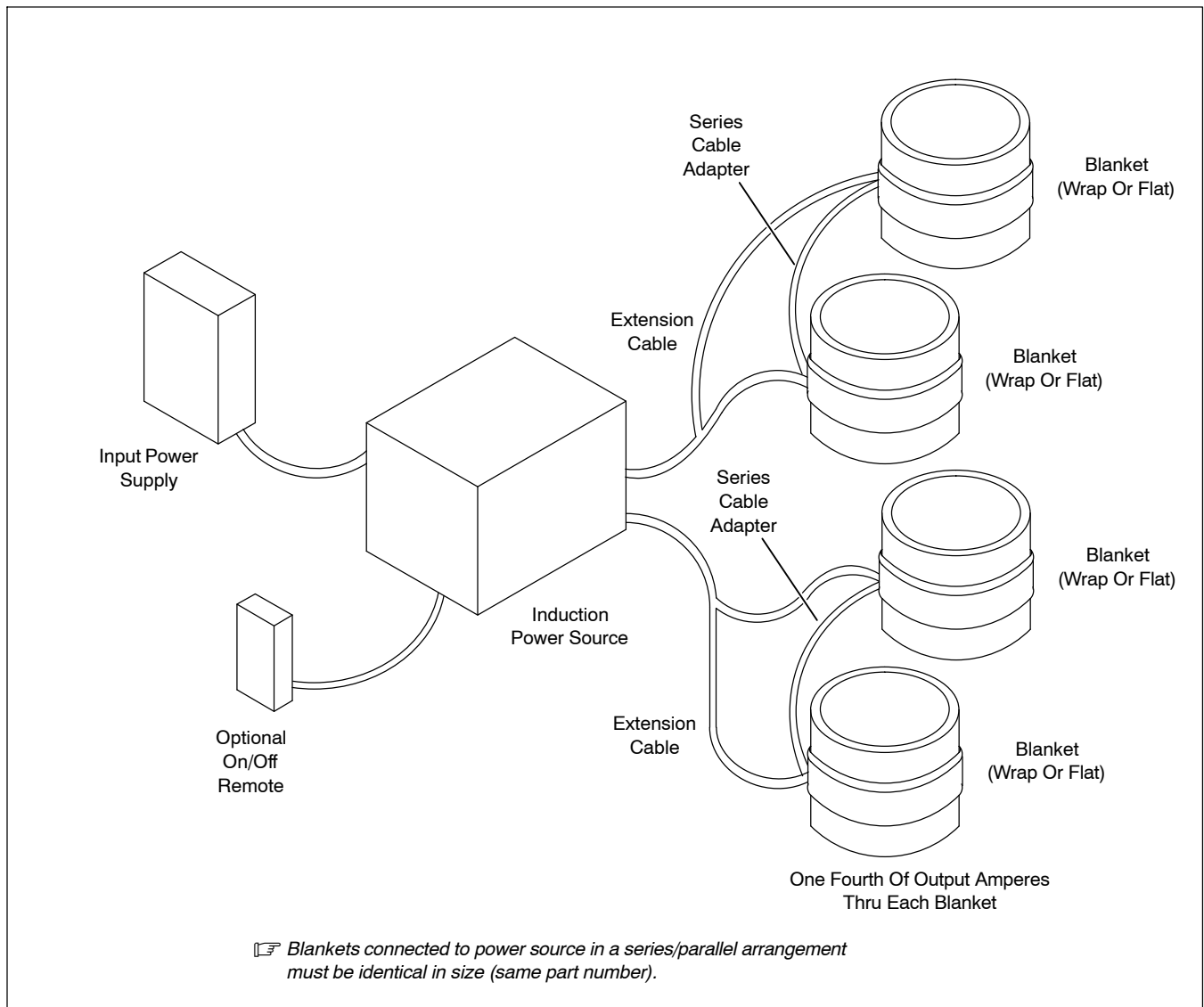

A four blanket series/parallel arrangement requires four equally sized blankets, two extension cables and two series adapter cables connected to a single power source. The output power from the power source will divide equally between the four blankets (assuming all blankets are in direct contact with the surface of the material to be heated). The output current for this arrangement will be very comparable to that of a single blanket arrangement, approximately 224 amperes. This output divides equally between the two pairs of blankets resulting in each blanket receiving approximately 112 amperes. Since the series/parallel amperage is below the 160 amperes maximum, long-term operation (100% duty cycle) is acceptable.

Duty Cycle For Narrow Air-Cooled Blankets

D. Narrow Blanket Arrangement

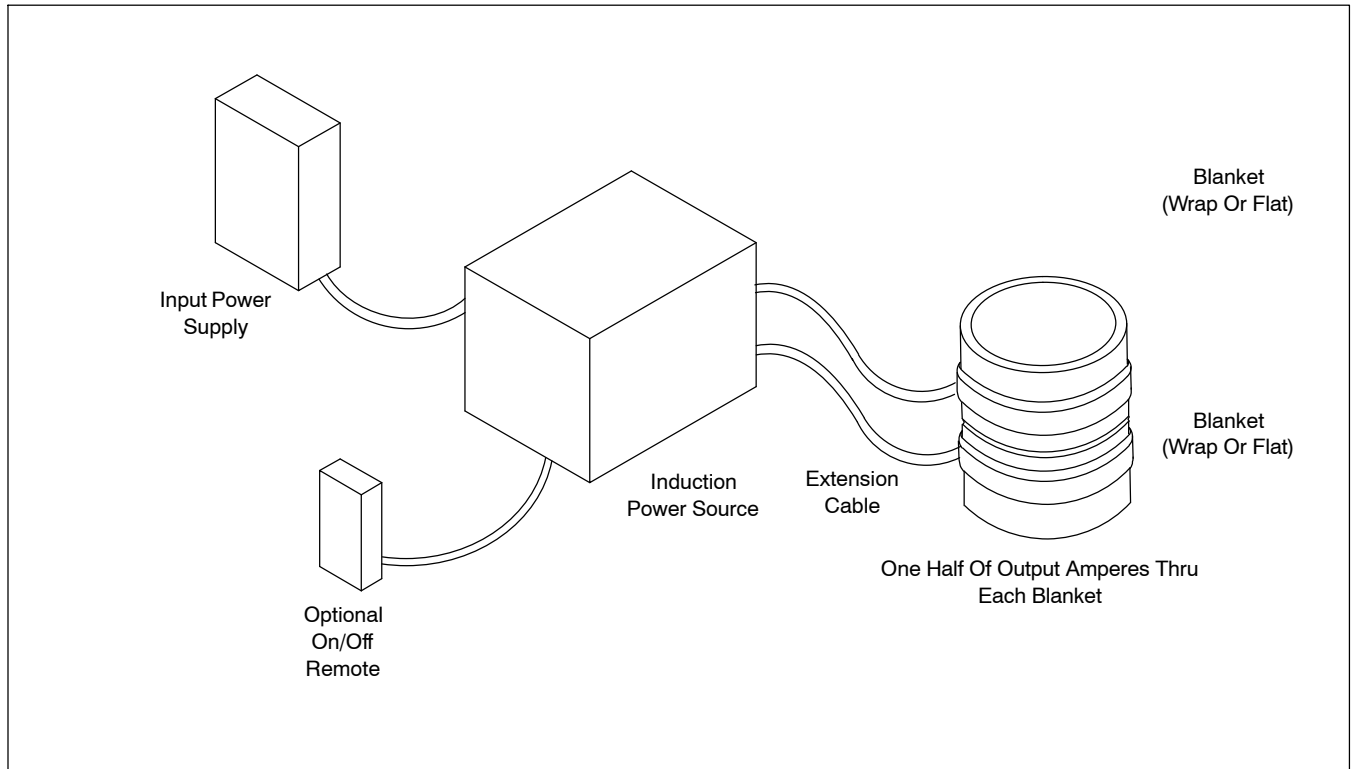

A two narrow blanket parallel arrangement requires two equally sized blankets and two extension cables connected to a single power source. One blanket should be positioned on each side of the weld joint approximately four inches apart and equally spaced from the joint. In order to achieve full power from the power source, the extension cables should be connected to the blankets as follows: cable A to blanket lead 1 and cable B to blanket lead 2 for one blanket; cable A to blanket lead 2 and cable B to to blanket lead 1 for the other blanket (see Section 4-3B). The output power from the power source will divide equally between the two blankets (assuming both blankets are in direct contact with the surface of the material to be heated). The power source will typically deliver approximately 500 amperes in this arrangement (~250A per blanket). For short duty cycle operation (less than 15 minutes) the wire in the blankets can withstand this current level. If operating at longer duty cycles (greater than 15 minutes), the power source will automatically reduce the output current (~300A total, ~150A per blanket) to prevent damage to the blankets.

E. Series/Parallel Narrow Blanket Arrangement

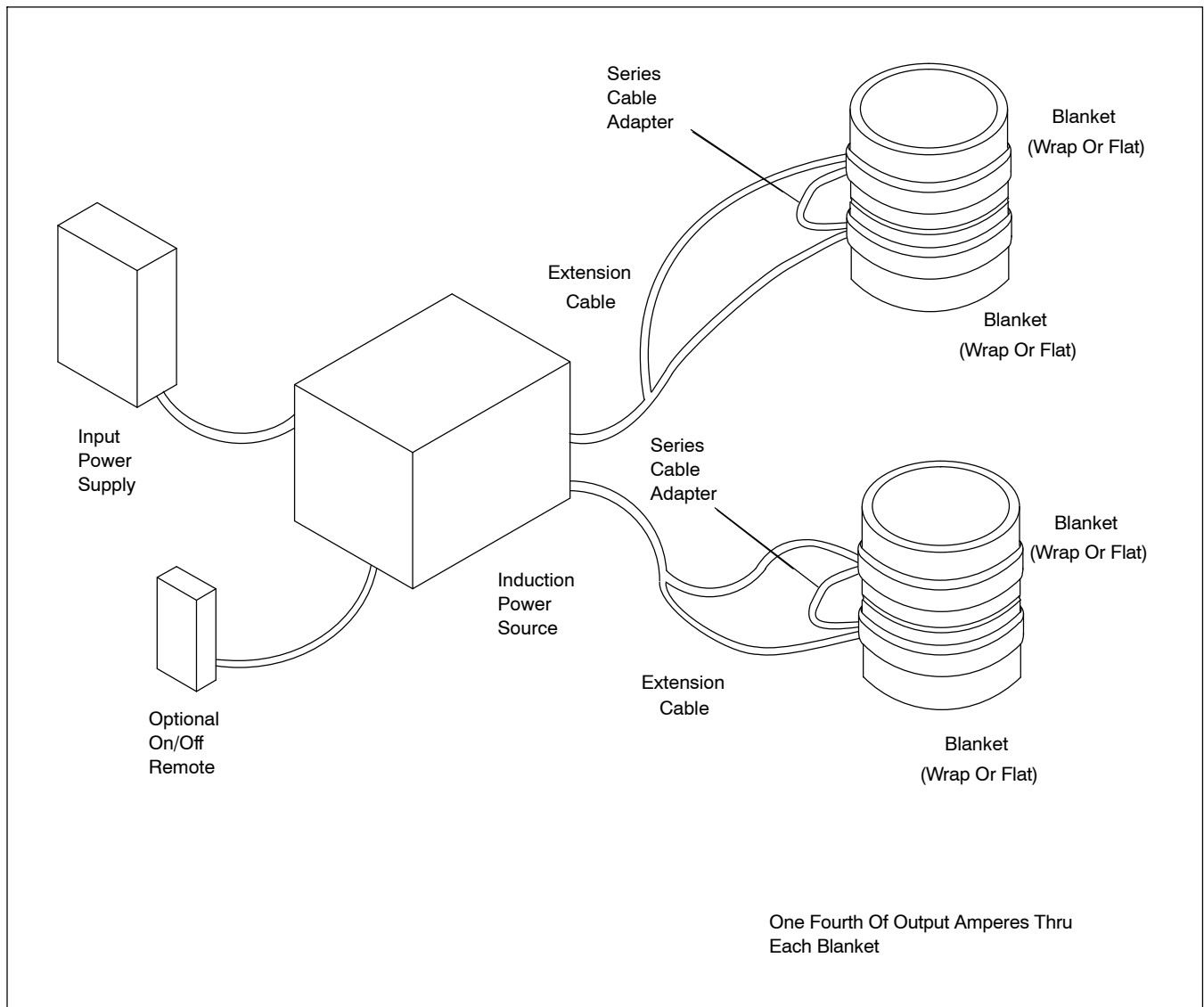

A four narrow blanket series/parallel arrangement requires four equally sized narrow blankets, two extension cables, and two series adapter cables connected to a single power source. One blanket should be positioned on each side of the weld joint approximately four inches apart and equally spaced from the joint. In order to achieve full power from the power source, the extension cables and series adapter should be connected to the blanket as follows: cable A to blanket lead 1 on one blanket and cable B to blanket lead 1 on the other blanket, series cable adapter from lead 2 of one blanket to lead 2 from the other blanket (see Section 4-3C). Set up should be the same for the other pair of blankets. The output power from the power source will divide equally between the four blankets (assuming all blankets are in direct contact with the surface of the material to be heated). The output current for this arrangement will be comparable to the two narrow blanket arrangement.

SECTION 6 – MAINTENANCE

Prior to each use, visually inspect blanket for wear, rips, tears, sewn seams coming loose, broken or split insulation. Replace blanket if necessary.

NOTICE – If blanket surface is torn to the point that internal cable insulation is exposed to the outside, blanket must be replaced; if insulation is torn on connector cables exposing internal wiring, blanket must be replaced (see Section 6-1). **Do not attempt to repair blanket under any circumstances. Failure to comply with product maintenance schedule will void warranty.**

Clean mud or dirt from blanket, straps, wires and connectors on a daily basis to maintain efficient operation and consistent heating. Surface of blanket that contacts metal pipe or metal part must be kept free of debris at all times.

Inspect induction blanket sleeve and blanket for worn spots or damage such as holes, tears, exposed wires, etc. or lack of blanket flexibility (i.e. unusually stiff blanket), replace sleeve or blanket if necessary.

To help prevent rapid wear and breakdown of blanket and sleeve insulating surface, apply GE® RTV 116 silicone coating material to worn areas as necessary. For more information on where to purchase GE RTV 116 silicone, call the Momentive Information Center at 1-800-295-2392.

6-1. Precautionary Labels

<p>⚠ WARNING / AVERTISSEMENT / ADVERTENCIA</p> <p>ELECTRIC SHOCK can kill.</p> <ul style="list-style-type: none"> Do not disconnect cables during operation. Turn off power source before making or changing connections. Be sure electrical connectors are fully engaged and locked before use. 	<p>UNE DÉCHARGE ÉLECTRIQUE peut être mortelle.</p> <ul style="list-style-type: none"> Ne pas débrancher les câbles lorsque l'appareil est en fonction. Couper la source de courant de soudage avant de faire ou de modifier tout raccordement. S'assurer que les connecteurs électriques sont enfoncés complètement avant l'utilisation de l'appareil.
<p>⚠ WARNING / AVERTISSEMENT / ADVERTENCIA</p> <p>ELECTRIC SHOCK can kill.</p> <ul style="list-style-type: none"> Do not disconnect cables during operation. Turn off power source before making or changing connections. Be sure electrical connectors are fully engaged and locked before use. 	<p>UNA DESCARGA ELÉCTRICA puede matarlo.</p> <ul style="list-style-type: none"> No desconecte los cables durante el funcionamiento. Apague la fuente de alimentación antes de realizar o cambiar cualquier conexión. Asegúrese de que todos los enchufes están correctamente conectados antes de usarlos.
<p>⚠ WARNING / AVERTISSEMENT / ADVERTENCIA</p> <p>INDUCTION HEATING can burn.</p> <ul style="list-style-type: none"> Do not handle, touch, or remove induction coil/blanket during operation. Allow cooling period before handling parts. 	<p>LE CHAUFFAGE PAR INDUCTION peut provoquer des brûlures.</p> <ul style="list-style-type: none"> Ne pas toucher, manipuler ou enlever les bobines d'induction ou les couvertures chauffantes pendant le fonctionnement de l'appareil. Laisser refroidir les pièces avant de les manipuler.
<p>⚠ WARNING / AVERTISSEMENT / ADVERTENCIA</p> <p>INDUCTION HEATING can burn.</p> <ul style="list-style-type: none"> Do not handle, touch, or remove induction coil/blanket during operation. Allow cooling period before handling parts. 	<p>EI CALENTAMIENTO POR INDUCCIÓN pueden ocasionar quemaduras.</p> <ul style="list-style-type: none"> No maneje, toque ni extraiga la lámina/capa de aluminio por inducción durante el funcionamiento. Espere a que finalice el período de enfriamiento antes de manipular las piezas.
<p>⚠ WARNING / AVERTISSEMENT / ADVERTENCIA</p> <p>ELECTRIC AND MAGNETIC FIELDS (EMF) can affect pacemakers.</p> <ul style="list-style-type: none"> Pacemaker wearers keep away. Wearers should consult their doctor before going near induction heating operations. 	<p>LES CHAMPS ÉLECTROMAGNÉTIQUES peuvent nuire au fonctionnement des stimulateurs cardiaques.</p> <ul style="list-style-type: none"> Les personnes qui portent un stimulateur cardiaque doivent se tenir à distance. Les personnes qui portent un stimulateur cardiaque doivent consulter leur médecin avant de s'approcher d'une source de chauffage par induction.
<p>⚠ WARNING / AVERTISSEMENT / ADVERTENCIA</p> <p>ELECTRIC AND MAGNETIC FIELDS (EMF) can affect pacemakers.</p> <ul style="list-style-type: none"> Pacemaker wearers keep away. Wearers should consult their doctor before going near induction heating operations. 	<p>LOS CAMPOS ELÉCTRICOS Y MAGNÉTICOS (CEM) pueden afectar a los marcapasos.</p> <ul style="list-style-type: none"> Personas con marcapasos de paso manténgase lejos. Las personas que los llevan deberán consultar con su médico antes de acercarse a lugares donde se estén realizando operaciones de calentamiento por inducción.
<p>Visually inspect condition of blanket and cables before each use. Do not use damaged blanket or cables. Install blanket with label side of blanket away from surface being heated.</p>	
<p>Effectuer une inspection visuelle de la couverture et des câbles avant chaque utilisation. Ne pas utiliser la couverture ou les câbles si endommagés. La couverture doit être mise en place avec l'étiquette pointant vers l'extérieur et non vers la surface à chauffer.</p>	<p>Inspeccione visualmente las condiciones de la capa y de los cables antes de cada uso. No utilice capas o cables dañados. Instale la capa con el lado de la etiqueta lejos de la superficie a calentar.</p>

1 Induction Blanket Sleeve

2 Induction Heating Blanket

3 Precautionary Label

Be sure to read and follow information on precautionary label.

<p>⚠ WARNING / AVERTISSEMENT / ADVERTENCIA</p> <p>ELECTRIC SHOCK can kill.</p> <ul style="list-style-type: none"> Do not disconnect cables during operation. Turn off power source before making or changing connections. Be sure electrical connectors are fully engaged and locked before use. 	<p>ELECTRIC SHOCK can kill.</p> <ul style="list-style-type: none"> Do not disconnect cables during operation. Turn off power source before making or changing connections. Be sure electrical connectors are fully engaged and locked before use.
<p>⚠ WARNING / AVERTISSEMENT / ADVERTENCIA</p> <p>INDUCTION HEATING can burn.</p> <ul style="list-style-type: none"> Do not handle, touch, or remove induction coil/blanket during operation. Allow cooling period before handling parts. 	<p>INDUCTION HEATING can burn.</p> <ul style="list-style-type: none"> Do not handle, touch, or remove induction coil/blanket during operation. Allow cooling period before handling parts.
<p>⚠ WARNING / AVERTISSEMENT / ADVERTENCIA</p> <p>ELECTRIC AND MAGNETIC FIELDS (EMF) can affect pacemakers.</p> <ul style="list-style-type: none"> Pacemaker wearers keep away. Wearers should consult their doctor before going near induction heating operations. 	<p>ELECTRIC AND MAGNETIC FIELDS (EMF) can affect pacemakers.</p> <ul style="list-style-type: none"> Pacemaker wearers keep away. Wearers should consult their doctor before going near induction heating operations.
<p>Visually inspect condition of blanket and cables before each use. Do not use damaged blanket or cables. Install blanket with label side of blanket away from surface being heated.</p>	

SECTION 8 – PARTS LIST

Hardware is common and not available unless listed.

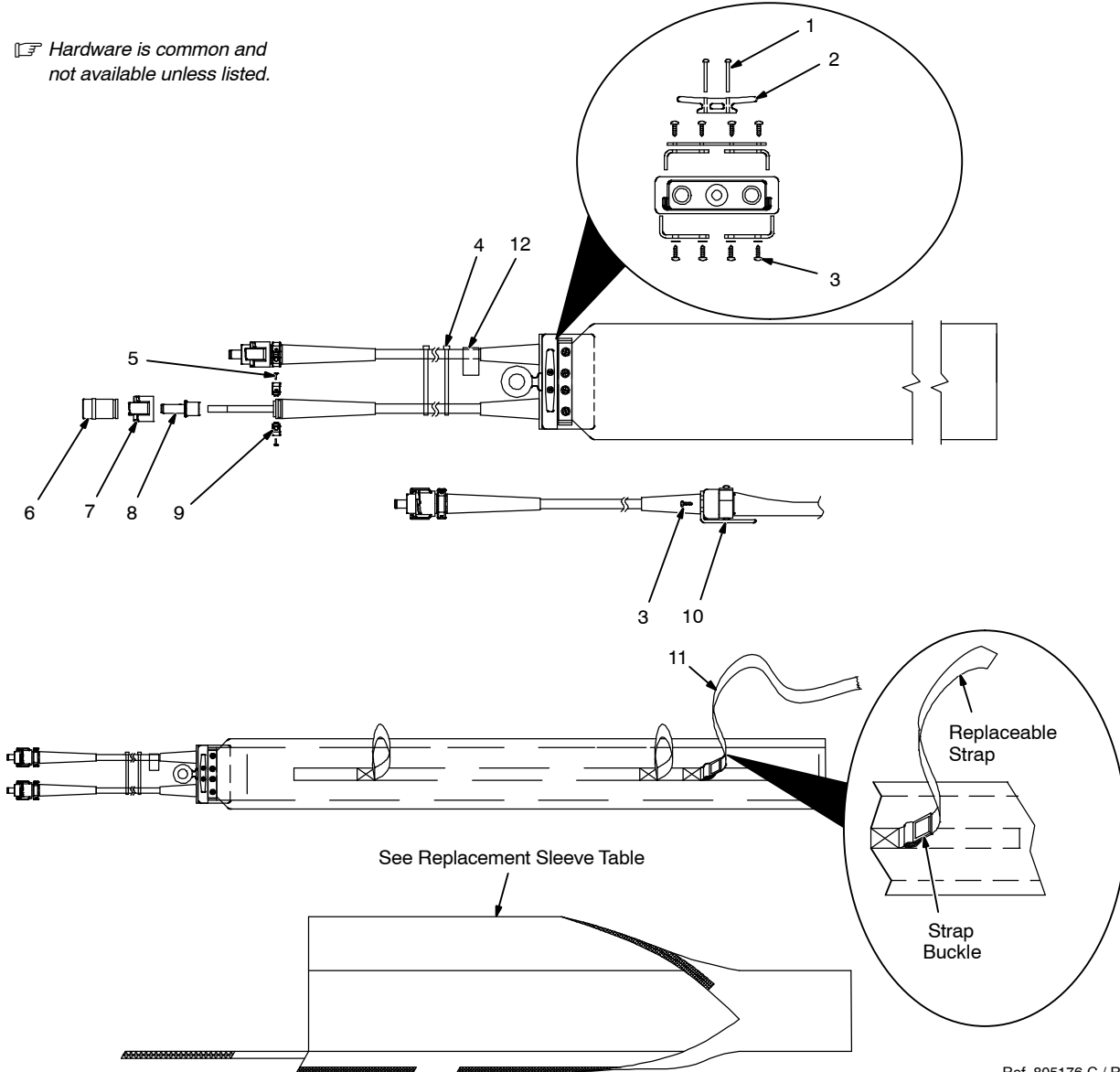

Ref. 805176-C / Ref. 805174-C

Figure 8-1. Induction Blanket And Sleeve

Item No.	Part No.	Description	Quantity				
Figure 8-1. Induction Blanket And Sleeve							
...	1	...	196666	..	Screw, 008-32 x 1.50 Rnd Hd-Slt Brs	...	2
...	2	...	196665	..	Cleat, Rope 4 in. Nylon	...	1
...	3	...	196669	..	Screw, 010-12 x .63 Pan Hd-Phi Sst Pln Sht Met Ab	...	6
...	4	...	020265	..	Cable Tie, 0-1 .750 Bundle Dia Sst2s-Mp	...	2
...	5	...	228296	..	Screw, Ka35 x 10 Pan Hd-Phi Sst Pln Pt Thread Forming	...	4
...	6	...	254889	..	Shell, Connector Cable Male	...	2
...	7	...	254890	..	Collar, Coupling	...	2
...	8	...	224145	..	Pin, Radsok 14mm Cable End	...	2
...	9	...	224258	..	Clamp, Strain Relief Pin	...	4
...	10	...	196965	..	Wearplate, Induction Blanket 6.125 in. wide	...	1
...	10	...	259960	..	Wearplate, Induction Blanket 5.000 in. wide	...	1
...	11	...	197866	..	Strap, Replacement	...	1
...	12	...	274885	..	Label,Warning Read Owner'S Manual Wordless Wrap	...	1

To maintain the factory original performance of your equipment, use only Manufacturer's Suggested Replacement Parts.

Replacement Sleeve Table

Replacement Sleeve Part No.	Blanket Part No.	Dimensions of Blankets Covered by Sleeve	Pipe Fit Diameter (w/Induction Blanket Sleeve)
195337	300080	Length: 40 in. (102 cm); Width: 13-1/8 in. (333 mm)	8-5/8 in. (22 cm) Dia
195338	300079	Length: 44 in. (112 cm); Width: 11-1/4 (286 mm)	10-3/4 in. (27 cm) Dia
194887	300078	Length: 47 in. (119 cm); Width: 10-1/8 (257 mm)	12 in. (31 cm) Dia
	300077	Length: 53 in. (135 cm); Width: 10-1/8 (257 mm)	14 in. (36 cm) Dia
	300075	Length: 60 in. (152 cm); Width: 10-1/8 (257 mm)	16 in. (41 cm) Dia
198666	300074	Length: 66 in. (168 cm); Width: 9 in. (23 cm)	18 in. (46 cm) Dia
	300073	Length: 72 in. (183 cm); Width: 9 in. (23 cm)	20 in. (51 cm) Dia
	300072	Length: 78 in. (198 cm); Width: 9 in. (23 cm)	22 in. (56 cm) Dia
	300071	Length: 85 in. (216 cm); Width: 9 in. (23 cm)	24 in. (61 cm) Dia
	300070	Length: 91 in. (231 cm); Width: 9 in. (23 cm)	26 in. (66 cm) Dia
194812	300069	Length: 97 in. (246 cm); Width: 9 in. (23 cm)	28 in. (71 cm) Dia
	300068	Length: 104 in. (264 cm); Width: 9 in. (23 cm)	30 in. (76 cm) Dia
	300067	Length: 110 in. (279 cm); Width: 9 in. (23 cm)	32 in. (81 cm) Dia
	300066	Length: 116 in. (295 cm); Width: 9 in. (23 cm)	34 in. (86 cm) Dia
194705	300065	Length: 122 in. (310 cm); Width: 7-1/2 in. (19 cm)	36 in. (91 cm) Dia
198670	300064	Length: 129 in. (328 cm); Width: 7-1/2 in. (19 cm)	38 in. (97 cm) Dia
	300087	Length: 135 in. (343 cm); Width: 7-1/2 in. (19 cm)	40 in. (102 cm) Dia
	300063	Length: 141 in. (358 cm); Width: 7-1/2 in. (19 cm)	42 in. (107 cm) Dia
	300062	Length: 154 in. (391 cm); Width: 7-1/2 in. (19 cm)	46 in. (117 cm) Dia
	300061	Length: 160 in. (406 cm); Width: 7-1/2 in. (19 cm)	48 in. (122 cm) Dia
261481	300060	Length: 173 in. (439 cm); Width: 7-1/2 in. (19 cm)	52 in. (132 cm) Dia
	244584	Length: 185 in. (470 cm); Width: 7-1/2 in. (19 cm)	56 in. (142 cm) Dia
	300336	Length: 195 in. (495 cm); Width: 7-1/2 in. (19 cm)	60 in. (152 cm) Dia
261480	301088	Length: 160 in. (406 cm); Width: 4-1/2 in. (11 cm)	48 in. (122 cm) Dia
	301089	Length: 185 in. (470 cm); Width: 4-1/2 in. (11 cm)	56 in. (143 cm) Dia

To maintain the factory original performance of your equipment, use only Manufacturer's Suggested Replacement Parts.

TRUE BLUE[®]

WARRANTY

Effective January 1, 2019

(Equipment with a serial number preface of MK or newer)

This limited warranty supersedes all previous Miller warranties and is exclusive with no other guarantees or warranties expressed or implied.

LIMITED WARRANTY – Subject to the terms and conditions below, Miller Electric Mfg. LLC, Appleton, Wisconsin, warrants to authorized distributors that new Miller equipment sold after the effective date of this limited warranty is free of defects in material and workmanship at the time it is shipped by Miller. THIS WARRANTY IS EXPRESSLY IN LIEU OF ALL OTHER WARRANTIES, EXPRESS OR IMPLIED, INCLUDING THE WARRANTIES OF MERCHANTABILITY AND FITNESS.

Within the warranty periods listed below, Miller will repair or replace any warranted parts or components that fail due to such defects in material or workmanship. Miller must be notified in writing within thirty (30) days of such defect or failure, at which time Miller will provide instructions on the warranty claim procedures to be followed. Notifications submitted as online warranty claims must provide detailed descriptions of the fault and troubleshooting steps taken to diagnose failed parts. Warranty claims that lack the required information as defined in the Miller Service Operation Guide (SOG) may be denied by Miller.

Miller shall honor warranty claims on warranted equipment listed below in the event of a defect within the warranty coverage time periods listed below. Warranty time periods start on the delivery date of the equipment to the end-user purchaser, or 12 months after the equipment is shipped to a North American distributor, or 18 months after the equipment is shipped to an international distributor, whichever occurs first.

1. 5 Years Parts — 3 Years Labor
 - * Original Main Power Rectifiers Only to Include SCRs, Diodes, and Discrete Rectifier Modules
2. 3 Years — Parts and Labor Unless Specified
 - * Auto-Darkening Helmet Lenses (No Labor) (See Classic Series Exception Below)
 - * Engine Driven Welder/Generators
(NOTE: Engines are Warranted Separately by the Engine Manufacturer.)
 - * Insight Welding Intelligence Products
 - * Inverter Power Sources
 - * Plasma Arc Cutting Power Sources
 - * Process Controllers
 - * Semi-Automatic and Automatic Wire Feeders
 - * Transformer/Rectifier Power Sources
3. 2 Years — Parts and Labor
 - * Auto-Darkening Helmet Lenses – Classic Series Only (No Labor)
 - * Auto-Darkening Weld Masks (No Labor)
 - * Fume Extractors – Capture 5, Filtair 400 and Industrial Collector Series
4. 1 Year — Parts and Labor Unless Specified
 - * AugmentedArc and LiveArc Welding Systems
 - * Automatic Motion Devices
 - * Bernard BTB Air-Cooled MIG Guns (No Labor)
 - * CoolBelt and CoolBand Blower Unit (No Labor)
 - * Desiccant Air Dryer System
 - * Field Options
(NOTE: Field options are covered for the remaining warranty period of the product they are installed in, or for a minimum of one year — whichever is greater.)
 - * RFCS Foot Controls (Except RFCS-RJ45)
 - * Fume Extractors – Filtair 130, MWX and SWX Series HF Units
 - * ICE/XT Plasma Cutting Torches (No Labor)
 - * Induction Heating Power Sources, Coolers
(NOTE: Digital Recorders are Warranted Separately by the Manufacturer.)
 - * Load Banks
 - * Motor-Driven Guns (except Spoolmate Spoolguns)
 - * PAPR Blower Unit (No Labor)
 - * Positioners and Controllers
 - * Racks (For Housing Multiple Power Sources)
 - * Running Gear/Trailers
 - * Spot Welders

- * Subarc Wire Drive Assemblies
 - * TIG Torches (No Labor)
 - * Tregaskiss Guns (No Labor)
 - * Water Cooling Systems
 - * Wireless Remote Foot/Hand Controls and Receivers
 - * Work Stations/Weld Tables (No Labor)
5. 6 Months — Parts
 - * Batteries
 6. 90 Days — Parts
 - * Accessories (Kits)
 - * Canvas Covers
 - * Induction Heating Coils and Blankets, Cables, and Non-Electronic Controls
 - * M-Guns
 - * MIG Guns, Subarc (SAW) Torches, and External Cladding Heads
 - * Remote Controls and RFCS-RJ45
 - * Replacement Parts (No labor)
 - * Spoolmate Spoolguns

Miller's True Blue[®] Limited Warranty shall not apply to:

1. **Consumable components; such as contact tips, cutting nozzles, contactors, brushes, relays, work station table tops and welding curtains, or parts that fail due to normal wear. (Exception: brushes and relays are covered on all engine-driven products.)**
2. Items furnished by Miller, but manufactured by others, such as engines or trade accessories. These items are covered by the manufacturer's warranty, if any.
3. Equipment that has been modified by any party other than Miller, or equipment that has been improperly installed, improperly operated or misused based upon industry standards, or equipment which has not had reasonable and necessary maintenance, or equipment which has been used for operation outside of the specifications for the equipment.
4. Defects caused by accident, unauthorized repair, or improper testing.

MILLER PRODUCTS ARE INTENDED FOR COMMERCIAL AND INDUSTRIAL USERS TRAINED AND EXPERIENCED IN THE USE AND MAINTENANCE OF WELDING EQUIPMENT.

The exclusive remedies for warranty claims are, at Miller's option, either: (1) repair; or (2) replacement; or, if approved in writing by Miller, (3) the pre-approved cost of repair or replacement at an authorized Miller service station; or (4) payment of or credit for the purchase price (less reasonable depreciation based upon use). Products may not be returned without Miller's written approval. Return shipment shall be at customer's risk and expense.

The above remedies are F.O.B. Appleton, WI, or Miller's authorized service facility. Transportation and freight are the customer's responsibility. TO THE EXTENT PERMITTED BY LAW, THE REMEDIES HEREIN ARE THE SOLE AND EXCLUSIVE REMEDIES REGARDLESS OF THE LEGAL THEORY. IN NO EVENT SHALL MILLER BE LIABLE FOR DIRECT, INDIRECT, SPECIAL, INCIDENTAL OR CONSEQUENTIAL DAMAGES (INCLUDING LOSS OF PROFIT) REGARDLESS OF THE LEGAL THEORY. ANY WARRANTY NOT PROVIDED HEREIN AND ANY IMPLIED WARRANTY, GUARANTY, OR REPRESENTATION, INCLUDING ANY IMPLIED WARRANTY OF MERCHANTABILITY OR FITNESS FOR PARTICULAR PURPOSE, ARE EXCLUDED AND DISCLAIMED BY MILLER.

Some US states do not allow limiting the duration of an implied warranty or the exclusion of certain damages, so the above limitations may not apply to you. This warranty provides specific legal rights, and other rights may be available depending on your state. In Canada, some provinces provide additional warranties or remedies, and to the extent the law prohibits their waiver, the limitations set out above may not apply. This Limited Warranty provides specific legal rights, and other rights may be available, but may vary by province.

Warranty Questions?

Call
1-800-4-A-MILLER
for your local
Miller distributor.

Your distributor also gives you ...

Service

You always get the fast, reliable response you need. Most replacement parts can be in your hands in 24 hours.

Support

Need fast answers to the tough welding questions? Contact your distributor. The expertise of the distributor and Miller is there to help you, every step of the way.





Owner's Record

Please complete and retain with your personal records.

Model Name

Serial/Style Number

Purchase Date

(Date which equipment was delivered to original customer.)

Distributor

Address

City

State

Zip



For Service

Contact a DISTRIBUTOR or SERVICE AGENCY near you.

Always provide Model Name and Serial/Style Number.

Contact your Distributor for:

Welding Supplies and Consumables

Options and Accessories

Personal Safety Equipment

Service and Repair

Replacement Parts

Training (Schools, Videos, Books)

Technical Manuals (Servicing Information and Parts)

Circuit Diagrams

Welding Process Handbooks

To locate a Distributor or Service Agency visit www.millerwelds.com or call 1-800-4-A-Miller

Contact the Delivering Carrier to:

File a claim for loss or damage during shipment.

For assistance in filing or settling claims, contact your distributor and/or equipment manufacturer's Transportation Department.

Miller Electric Mfg. LLC

An Illinois Tool Works Company
1635 West Spencer Street
Appleton, WI 54914 USA

International Headquarters-USA

USA Phone: 920-735-4505 Auto-Attended
USA & Canada FAX: 920-735-4134
International FAX: 920-735-4125

For International Locations Visit
www.MillerWelds.com

