

Red-D-Arc Welderrentals

1-866-RED-D-ARC reddarc.com

Processes



Stick (SMAW) Welding



TIG (GTAW) Welding



MIG (GMAW) Welding



Flux Cored (FCAW) Welding



Air Carbon Arc (CAC-A) Cutting and Gouging

Description



Engine Driven Welding Generator

D550K HO

CC/CV DC Diesel Welder

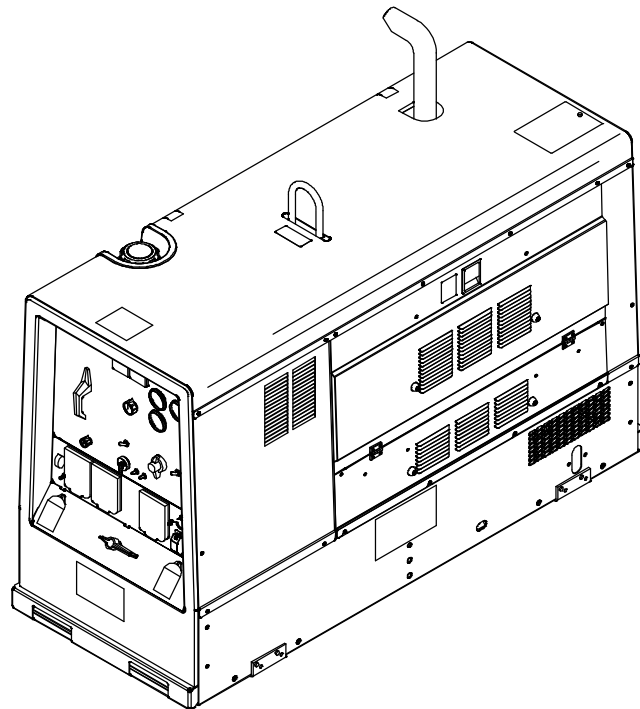

OWNER'S MANUAL

File: Engine Drive



TABLE OF CONTENTS

SECTION 1 – SAFETY PRECAUTIONS – READ BEFORE USING	1
1-1. Symbol Usage	1
1-2. Arc Welding Hazards	1
1-3. Engine Hazards	3
1-4. Hydraulic Hazards	4
1-5. Compressed Air Hazards	4
1-6. Additional Symbols For Installation, Operation, And Maintenance	5
1-7. California Proposition 65 Warnings	6
1-8. Principal Safety Standards	7
1-9. EMF Information	7
SECTION 2 – CONSIGNES DE SÉCURITÉ – LIRE AVANT UTILISATION	8
2-1. Signification des symboles	8
2-2. Dangers relatifs au soudage à l'arc	8
2-3. Dangers existant en relation avec le moteur	10
2-4. Dangers liés à l'hydraulique	11
2-5. Dangers liés à l'air comprimé	12
2-6. Dangers supplémentaires en relation avec l'installation, le fonctionnement et la maintenance	13
2-7. Proposition californienne 65 Avertissements	14
2-8. Principales normes de sécurité	15
2-9. Informations relatives aux CEM	15
SECTION 3 – DEFINITIONS	16
3-1. Symbols And Definitions	16
SECTION 4 – SPECIFICATIONS	17
4-1. Weld, Power, And Engine Specifications	17
4-2. Dimensions, Weights, And Operating Angles	17
4-3. Volt-Ampere Curves	18
4-4. Fuel Consumption	19
4-5. Duty Cycle And Overheating	19
4-6. Generator Power Curve	20
SECTION 5 – INSTALLATION	21
5-1. Serial Number And Rating Label Location	21
5-2. Installing Welding Generator	21
5-3. Mounting Welding Generator	22
5-4. Grounding Generator To Truck Or Trailer Frame	23
5-5. Using Lifting Eye	23
5-6. Installing Exhaust Pipe	24
5-7. Activating The Dry Charge Battery (If Applicable)	24
5-8. Connecting The Battery	25
5-9. Engine Prestart Checks	26
5-10. Weld Output Terminals	27
5-11. Connecting Weld Output Cables	27
5-12. Selecting Weld Cable Sizes*	28
5-13. Connecting To Remote 14 Receptacle RC14	29
SECTION 6 – OPERATING WELDING GENERATOR	30
6-1. Front Panel Controls (See Section 6-2)	30
6-2. Description Of Front Panel Controls (See Section 6-1)	31
6-3. Process/Contactor Control Switch	32
6-4. Remote Voltage/Amperage Control	33
6-5. Fuel/Hour Gauge Descriptions	34
SECTION 7 – OPERATING AUXILIARY EQUIPMENT	35
7-1. 120 Volt And 240 Volt Receptacles	35
7-2. Connecting To Three-Phase Generator	36

TABLE OF CONTENTS

SECTION 8 – MAINTENANCE & TROUBLESHOOTING	37
8-1. Maintenance Label	37
8-2. Routine Maintenance	38
8-3. Servicing Air Cleaner	39
8-4. Inspecting/Cleaning Optional Spark Arrestor	40
8-5. Checking Generator Brushes	40
8-6. Adjusting Engine Speed	41
8-7. Servicing Fuel And Lubrication Systems	42
8-8. Servicing Engine Cooling System	43
8-9. Overload Protection	44
8-10. Troubleshooting Tables	45
SECTION 9 – ELECTRICAL DIAGRAM	48
SECTION 10 – RUN-IN PROCEDURE	50
10-1. Wetstacking	50
10-2. Run-In Procedure Using Load Bank	51
10-3. Run-In Procedure Using Resistance Grid	52
SECTION 11 – GENERATOR POWER GUIDELINES	53
SECTION 12 – PARTS LIST	60
WARRANTY	

SECTION 1 – SAFETY PRECAUTIONS – READ BEFORE USING

rom_2011-04

 Protect yourself and others from injury — read, follow, and save these important safety precautions and operating instructions.

1-1. Symbol Usage



DANGER! – Indicates a hazardous situation which, if not avoided, will result in death or serious injury. The possible hazards are shown in the adjoining symbols or explained in the text.



Indicates a hazardous situation which, if not avoided, could result in death or serious injury. The possible hazards are shown in the adjoining symbols or explained in the text.

NOTICE – Indicates statements not related to personal injury.

 Indicates special instructions.



This group of symbols means Warning! Watch Out! ELECTRIC SHOCK, MOVING PARTS, and HOT PARTS hazards. Consult symbols and related instructions below for necessary actions to avoid the hazards.

1-2. Arc Welding Hazards



The symbols shown below are used throughout this manual to call attention to and identify possible hazards. When you see the symbol, watch out, and follow the related instructions to avoid the hazard. The safety information given below is only a summary of the more complete safety information found in the Safety Standards listed in Section 1-8. Read and follow all Safety Standards.



Only qualified persons should install, operate, maintain, and repair this unit.



During operation, keep everybody, especially children, away.



ELECTRIC SHOCK can kill.

Touching live electrical parts can cause fatal shocks or severe burns. The electrode and work circuit is electrically live whenever the output is on. The input power circuit and machine internal circuits are also live when power is on. In semiautomatic or automatic wire welding, the wire, wire reel, drive roll housing, and all metal parts touching the welding wire are electrically live. Incorrectly installed or improperly grounded equipment is a hazard.

- Do not touch live electrical parts.
- Wear dry, hole-free insulating gloves and body protection.
- Insulate yourself from work and ground using dry insulating mats or covers big enough to prevent any physical contact with the work or ground.
- Do not use AC output in damp areas, if movement is confined, or if there is a danger of falling.
- Use AC output ONLY if required for the welding process.
- If AC output is required, use remote output control if present on unit.
- Additional safety precautions are required when any of the following electrically hazardous conditions are present: in damp locations or while wearing wet clothing; on metal structures such as floors, gratings, or scaffolds; when in cramped positions such as sitting, kneeling, or lying; or when there is a high risk of unavoidable or accidental contact with the workpiece or ground. For these conditions, use the following equipment in order presented: 1) a semiautomatic DC constant voltage (wire) welder, 2) a DC manual (stick) welder, or 3) an AC welder with reduced open-circuit voltage. In most situations, use of a DC, constant voltage wire welder is recommended. And, do not work alone!
- Disconnect input power or stop engine before installing or servicing this equipment. Lockout/tagout input power according to OSHA 29 CFR 1910.147 (see Safety Standards).
- Properly install, ground, and operate this equipment according to its Owner's Manual and national, state, and local codes.

- Always verify the supply ground — check and be sure that input power cord ground wire is properly connected to ground terminal in disconnect box or that cord plug is connected to a properly grounded receptacle outlet.
- When making input connections, attach proper grounding conductor first – double-check connections.
- Keep cords dry, free of oil and grease, and protected from hot metal and sparks.
- Frequently inspect input power cord for damage or bare wiring — replace cord immediately if damaged — bare wiring can kill.
- Turn off all equipment when not in use.
- Do not use worn, damaged, undersized, or poorly spliced cables.
- Do not drape cables over your body.
- If earth grounding of the workpiece is required, ground it directly with a separate cable.
- Do not touch electrode if you are in contact with the work, ground, or another electrode from a different machine.
- Use only well-maintained equipment. Repair or replace damaged parts at once. Maintain unit according to manual.
- Do not touch electrode holders connected to two welding machines at the same time since double open-circuit voltage will be present.
- Wear a safety harness if working above floor level.
- Keep all panels and covers securely in place.
- Clamp work cable with good metal-to-metal contact to workpiece or worktable as near the weld as practical.
- Insulate work clamp when not connected to workpiece to prevent contact with any metal object.
- Do not connect more than one electrode or work cable to any single weld output terminal.

SIGNIFICANT DC VOLTAGE exists in inverter power sources AFTER stopping engine.

- Stop engine on inverter and discharge input capacitors according to instructions in Maintenance Section before touching any parts.



HOT PARTS can burn.

- Do not touch hot parts bare handed.
- Allow cooling period before working on equipment.
- To handle hot parts, use proper tools and/or wear heavy, insulated welding gloves and clothing to prevent burns.

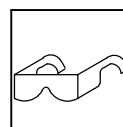

FLYING METAL or DIRT can injure eyes.

- Welding, chipping, wire brushing, and grinding cause sparks and flying metal. As welds cool, they can throw off slag.
- Wear approved safety glasses with side shields even under your welding helmet.



FUMES AND GASES can be hazardous.

Welding produces fumes and gases. Breathing these fumes and gases can be hazardous to your health.

- Keep your head out of the fumes. Do not breathe the fumes.
- If inside, ventilate the area and/or use local forced ventilation at the arc to remove welding fumes and gases.
- If ventilation is poor, wear an approved air-supplied respirator.
- Read and understand the Material Safety Data Sheets (MSDSs) and the manufacturer's instructions for metals, consumables, coatings, cleaners, and degreasers.
- Work in a confined space only if it is well ventilated, or while wearing an air-supplied respirator. Always have a trained watch-person nearby. Welding fumes and gases can displace air and lower the oxygen level causing injury or death. Be sure the breathing air is safe.
- Do not weld in locations near degreasing, cleaning, or spraying operations. The heat and rays of the arc can react with vapors to form highly toxic and irritating gases.
- Do not weld on coated metals, such as galvanized, lead, or cadmium plated steel, unless the coating is removed from the weld area, the area is well ventilated, and while wearing an air-supplied respirator. The coatings and any metals containing these elements can give off toxic fumes if welded.



BUILDUP OF GAS can injure or kill.

- Shut off shielding gas supply when not in use.
- Always ventilate confined spaces or use approved air-supplied respirator.



ARC RAYS can burn eyes and skin.

Arc rays from the welding process produce intense visible and invisible (ultraviolet and infrared) rays that can burn eyes and skin. Sparks fly off from the weld.

- Wear an approved welding helmet fitted with a proper shade of filter lenses to protect your face and eyes from arc rays and sparks when welding or watching (see ANSI Z49.1 and Z87.1 listed in Safety Standards).
- Wear approved safety glasses with side shields under your helmet.
- Use protective screens or barriers to protect others from flash, glare, and sparks; warn others not to watch the arc.
- Wear protective clothing made from durable, flame-resistant material (leather, heavy cotton, or wool) and foot protection.



WELDING can cause fire or explosion.

Welding on closed containers, such as tanks, drums, or pipes, can cause them to blow up. Sparks can fly off from the welding arc. The flying sparks, hot workpiece, and hot equipment can cause fires and burns. Accidental contact of electrode to metal objects can cause sparks, explosion, overheating, or fire. Check and be sure the area is safe before doing any welding.

- Remove all flammables within 35 ft (10.7 m) of the welding arc. If this is not possible, tightly cover them with approved covers.
- Do not weld where flying sparks can strike flammable material.
- Protect yourself and others from flying sparks and hot metal.
- Be alert that welding sparks and hot materials from welding can easily go through small cracks and openings to adjacent areas.
- Watch for fire, and keep a fire extinguisher nearby.
- Be aware that welding on a ceiling, floor, bulkhead, or partition can cause fire on the hidden side.

- Do not weld on closed containers such as tanks, drums, or pipes, unless they are properly prepared according to AWS F4.1 (see Safety Standards).
- Do not weld where the atmosphere may contain flammable dust, gas, or liquid vapors (such as gasoline).
- Connect work cable to the work as close to the welding area as practical to prevent welding current from traveling long, possibly unknown paths and causing electric shock, sparks, and fire hazards.
- Do not use welder to thaw frozen pipes.
- Remove stick electrode from holder or cut off welding wire at contact tip when not in use.
- Wear oil-free protective garments such as leather gloves, heavy shirt, cuffless trousers, high shoes, and a cap.
- Remove any combustibles, such as a butane lighter or matches, from your person before doing any welding.
- After completion of work, inspect area to ensure it is free of sparks, glowing embers, and flames.
- Use only correct fuses or circuit breakers. Do not oversize or bypass them.
- Follow requirements in OSHA 1910.252 (a) (2) (iv) and NFPA 51B for hot work and have a fire watcher and extinguisher nearby.

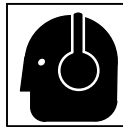

NOISE can damage hearing.

Noise from some processes or equipment can damage hearing.

- Wear approved ear protection if noise level is high.



ELECTRIC AND MAGNETIC FIELDS (EMF) can affect Implanted Medical Devices.

- Wearers of Pacemakers and other Implanted Medical Devices should keep away.
- Implanted Medical Device wearers should consult their doctor and the device manufacturer before going near arc welding, spot welding, gouging, plasma arc cutting, or induction heating operations.



CYLINDERS can explode if damaged.

Shielding gas cylinders contain gas under high pressure. If damaged, a cylinder can explode. Since gas cylinders are normally part of the welding process, be sure to treat them carefully.

- Protect compressed gas cylinders from excessive heat, mechanical shocks, physical damage, slag, open flames, sparks, and arcs.
- Install cylinders in an upright position by securing to a stationary support or cylinder rack to prevent falling or tipping.
- Keep cylinders away from any welding or other electrical circuits.
- Never drape a welding torch over a gas cylinder.
- Never allow a welding electrode to touch any cylinder.
- Never weld on a pressurized cylinder — explosion will result.
- Use only correct shielding gas cylinders, regulators, hoses, and fittings designed for the specific application; maintain them and associated parts in good condition.
- Turn face away from valve outlet when opening cylinder valve.
- Keep protective cap in place over valve except when cylinder is in use or connected for use.
- Use the right equipment, correct procedures, and sufficient number of persons to lift and move cylinders.
- Read and follow instructions on compressed gas cylinders, associated equipment, and Compressed Gas Association (CGA) publication P-1 listed in Safety Standards.

1-3. Engine Hazards



BATTERY EXPLOSION can injure.

- Always wear a face shield, rubber gloves, and protective clothing when working on a battery.
- Stop engine before disconnecting or connecting battery cables, battery charging cables (if applicable), or servicing battery.
- Do not allow tools to cause sparks when working on a battery.
- Do not use welder to charge batteries or jump start vehicles unless the unit has a battery charging feature designed for this purpose.
- Observe correct polarity (+ and -) on batteries.
- Disconnect negative (-) cable first and connect it last.
- Keep sparks, flames, cigarettes, and other ignition sources away from batteries. Batteries produce explosive gases during normal operation and when being charged.
- Follow battery manufacturer's instructions when working on or near a battery.

BATTERY CHARGING OUTPUT can injure. (Battery charging feature not present on all models.)

- Have only qualified persons do battery charging work.
- Charge lead-acid batteries only. Do not use battery charger to supply power to an extra-low-voltage electrical system or to charge dry cell batteries.
- Do not charge a frozen battery.
- Do not use damaged charging cables.
- Do not charge a battery that has loose terminals or one showing damage such as a cracked case or cover.
- Before charging battery, select correct charger voltage to match battery voltage.
- Set battery charging controls to the Off position before connecting to battery. Do not allow battery charging clips to touch each other.
- Keep charging cables away from vehicle hood, door, or moving parts.



FUEL can cause fire or explosion.

- Stop engine and let it cool off before checking or adding fuel.
- Do not add fuel while smoking or if unit is near any sparks or open flames.
- Do not overfill tank — allow room for fuel to expand.
- Do not spill fuel. If fuel is spilled, clean up before starting engine.
- Dispose of rags in a fireproof container.
- Always keep nozzle in contact with tank when fueling.



MOVING PARTS can injure.

- Keep away from moving parts such as fans, belts, and rotors.
- Keep all doors, panels, covers, and guards closed and securely in place.
- Stop engine before installing or connecting unit.
- Have only qualified persons remove doors, panels, covers, or guards for maintenance and troubleshooting as necessary.
- To prevent accidental starting during servicing, disconnect negative (-) battery cable from battery.
- Keep hands, hair, loose clothing, and tools away from moving parts.
- Reinstall doors, panels, covers, or guards when servicing is finished and before starting engine.
- Before working on generator, remove spark plugs or injectors to keep engine from kicking back or starting.
- Block flywheel so that it will not turn while working on generator components.



EXHAUST SPARKS can cause fire.

- Do not let engine exhaust sparks cause fire.
- Use approved engine exhaust spark arrestor in required areas — see applicable codes.



HOT PARTS can burn.

- Do not touch hot parts bare handed.
- Allow cooling period before working on equipment.
- To handle hot parts, use proper tools and/or wear heavy, insulated welding gloves and clothing to prevent burns.

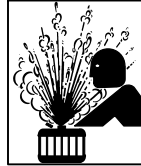

STEAM AND HOT COOLANT can burn.

- If possible, check coolant level when engine is cold to avoid scalding.
- Always check coolant level at overflow tank, if present on unit, instead of radiator (unless told otherwise in maintenance section or engine manual).
- If the engine is warm, checking is needed, and there is no overflow tank, follow the next two statements.
- Wear safety glasses and gloves and put a rag over radiator cap.
- Turn cap slightly and let pressure escape slowly before completely removing cap.

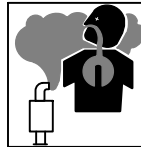

Using a generator indoors CAN KILL YOU IN MINUTES.

- Generator exhaust contains carbon monoxide. This is a poison you cannot see or smell.
- NEVER use inside a home or garage, EVEN IF doors and windows are open.
- Only use OUTSIDE and far away from windows, doors, and vents.

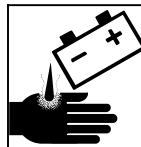

BATTERY ACID can BURN SKIN and EYES.

- Do not tip battery.
- Replace damaged battery.
- Flush eyes and skin immediately with water.



ENGINE HEAT can cause fire.

- Do not locate unit on, over, or near combustible surfaces or flammables.
- Keep exhaust and exhaust pipes way from flammables.

1-4. Hydraulic Hazards

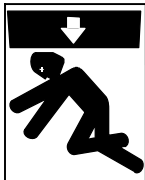

HYDRAULIC EQUIPMENT can injure or kill.

- Incorrect installation or operation of this unit could result in equipment failure and personal injury. Only qualified persons should install, operate, and service this unit according to its Owner's Manual, industry standards, and national, state, and local codes.
- Do not exceed the rated output or capacity of the hydraulic pump or any equipment in the hydraulic system. Design hydraulic system so failure of any hydraulic component will not put people or property at risk.
- Before working on hydraulic system, turn off and lockout/tagout unit, release pressure, and be sure hydraulic pressure cannot be accidentally applied.
- Do not work on hydraulic system with unit running unless you are a qualified person and following the manufacturer's instructions.
- Do not modify or alter hydraulic pump or manufacturer-supplied equipment. Do not disconnect, disable, or override any safety equipment in the hydraulic system.
- Use only components/accessories approved by the manufacturer.
- Keep away from potential pinch points or crush points created by equipment connected to the hydraulic system.
- Do not work under or around any equipment that is supported only by hydraulic pressure. Properly support equipment by mechanical means.



HYDRAULIC FLUID can injure or kill.

- Before working on hydraulic system, turn off and lockout/tagout unit, release pressure, and be sure hydraulic pressure cannot be accidentally applied.
- Relieve pressure before disconnecting or connecting hydraulic lines.
- Check hydraulic system components and all connections and hoses for damage, leaks, and wear before operating unit.
- Wear protective equipment such as safety glasses, leather gloves, heavy shirt and trousers, high shoes, and a cap when working on hydraulic system.

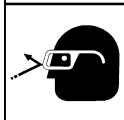

- Use a piece of paper or cardboard to search for leaks—never use bare hands. Do not use equipment if leaks are found.

- HYDRAULIC FLUID is FLAMMABLE—do not work on hydraulics near sparks or flames; do not smoke near hydraulic fluid.
- Reinstall doors, panels, covers, or guards when servicing is finished and before starting unit.
- If ANY fluid is injected into the skin, it must be surgically removed within a few hours by a doctor familiar with this type of injury or gangrene may result.



MOVING PARTS can injure.

- Keep away from moving parts such as fans, belts and rotors.
- Keep all doors, panels, covers, and guards closed and securely in place.
- Keep hands, hair, loose clothing, and tools away from moving parts.
- Before working on hydraulic system, turn off and lockout/tagout unit, release pressure, and be sure hydraulic pressure cannot be accidentally applied.
- Have only qualified people remove guards or covers for maintenance and troubleshooting as necessary.
- Reinstall doors, panels, covers, or guards when servicing is finished and before starting engine.



HOT PARTS AND FLUID can burn.

- Do not touch hot parts bare handed or allow hot fluid to contact skin.
- Allow cooling period before working on equipment.
- To handle hot parts, use proper tools and/or wear heavy, insulated welding gloves and clothing to prevent burns.

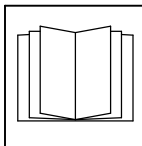

READ INSTRUCTIONS.

- Read and follow all labels and the Owner's Manual carefully before installing, operating, or servicing unit. Read the safety information at the beginning of the manual and in each section.
- Use only genuine replacement parts from the manufacturer.
- Perform maintenance and service according to the Owner's Manuals, industry standards, and national, state, and local codes.

1-5. Compressed Air Hazards



COMPRESSED AIR EQUIPMENT can injure or kill.

- Incorrect installation or operation of this unit could result in equipment failure and personal injury. Only qualified persons should install, operate, and service this unit according to its Owner's Manual, industry standards, and national, state, and local codes.
- Do not exceed the rated output or capacity of the compressor or any equipment in the compressed air system. Design compressed air system so failure of any component will not put people or property at risk.
- Before working on compressed air system, turn off and lockout/tagout unit, release pressure, and be sure air pressure cannot be accidentally applied.

- Do not work on compressed air system with unit running unless you are a qualified person and following the manufacturer's instructions.
- Do not modify or alter compressor or manufacturer-supplied equipment. Do not disconnect, disable, or override any safety equipment in the compressed air system.
- Use only components and accessories approved by the manufacturer.
- Keep away from potential pinch points or crush points created by equipment connected to the compressed air system.
- Do not work under or around any equipment that is supported only by air pressure. Properly support equipment by mechanical means.



HOT METAL from air arc cutting and gouging can cause fire or explosion.

- Do not cut or gouge near flammables.
- Watch for fire; keep extinguisher nearby.



COMPRESSED AIR can injure or kill.

- Before working on compressed air system, turn off and lockout/tagout unit, release pressure, and be sure air pressure cannot be accidentally applied.
- Relieve pressure before disconnecting or connecting air lines.
- Check compressed air system components and all connections and hoses for damage, leaks, and wear before operating unit.

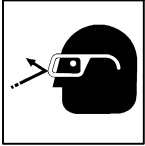

- Do not direct air stream toward self or others.
- Wear protective equipment such as safety glasses, hearing protection, leather gloves, heavy shirt and trousers, high shoes, and a cap when working on compressed air system.
- Use soapy water or an ultrasonic detector to search for leaks—never use bare hands. Do not use equipment if leaks are found.
- Reinstall doors, panels, covers, or guards when servicing is finished and before starting unit.
- If ANY air is injected into the skin or body seek medical help immediately.



BREATHING COMPRESSED AIR can injure or kill.

- Do not use compressed air for breathing.
- Use only for cutting, gouging, and tools.



TRAPPED AIR PRESSURE AND WHIPPING HOSES can injure.

- Release air pressure from tools and system before servicing, adding or changing attachments, or opening compressor oil drain or oil fill cap.



MOVING PARTS can injure.

- Keep away from moving parts such as fans, belts and rotors.
- Keep all doors, panels, covers, and guards closed and securely in place.

- Keep hands, hair, loose clothing, and tools away from moving parts.
- Before working on compressed air system, turn off and lockout/tagout unit, release pressure, and be sure air pressure cannot be accidentally applied.
- Have only qualified people remove guards or covers for maintenance and troubleshooting as necessary.
- Reinstall doors, panels, covers, or guards when servicing is finished and before starting engine.



HOT PARTS can burn.

- Do not touch hot compressor or air system parts.
- Allow cooling period before working on equipment.

- To handle hot parts, use proper tools and/or wear heavy, insulated welding gloves and clothing to prevent burns.

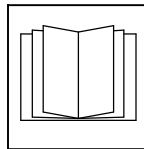

READ INSTRUCTIONS.

- Read and follow all labels and the Owner's Manual carefully before installing, operating, or servicing unit. Read the safety information at the beginning of the manual and in each section.

- Use only genuine replacement parts from the manufacturer.
- Perform maintenance and service according to the Owner's Manuals, industry standards, and national, state, and local codes.

1-6. Additional Symbols For Installation, Operation, And Maintenance



FIRE OR EXPLOSION hazard.

- Do not install or place unit on, over, or near combustible surfaces.
- Do not install unit near flammables.
- Do not overload building wiring – be sure power supply system is properly sized, rated, and protected to handle this unit.

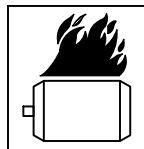

OVERHEATING can damage motors.

- Turn off or unplug equipment before starting or stopping engine.
- Do not let low voltage and frequency caused by low engine speed damage electric motors.
- Do not connect 50 or 60 Hertz motors to the 100 Hertz receptacle where applicable.



FALLING EQUIPMENT can injure.

- Use lifting eye to lift unit and properly installed accessories only, NOT gas cylinders. Do not exceed maximum lift eye weight rating (see Specifications).
- Use equipment of adequate capacity to lift and support unit.
- If using lift forks to move unit, be sure forks are long enough to extend beyond opposite side of unit.
- Keep equipment (cables and cords) away from moving vehicles when working from an aerial location.
- Follow the guidelines in the Applications Manual for the Revised NIOSH Lifting Equation (Publication No. 94-110) when manually lifting heavy parts or equipment.

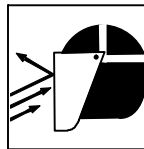

FLYING SPARKS can injure.

- Wear a face shield to protect eyes and face.
- Shape tungsten electrode only on grinder with proper guards in a safe location wearing proper face, hand, and body protection.
- Sparks can cause fires — keep flammables away.

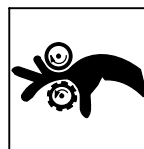

MOVING PARTS can injure.

- Keep away from moving parts.
- Keep away from pinch points such as drive rolls.



WELDING WIRE can injure.

- Do not press gun trigger until instructed to do so.
- Do not point gun toward any part of the body, other people, or any metal when threading welding wire.

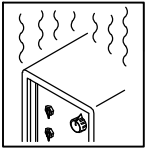

OVERUSE can cause OVERHEATING.

- Allow cooling period; follow rated duty cycle.
- Reduce current or reduce duty cycle before starting to weld again.
- Do not block or filter airflow to unit.

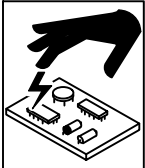

STATIC (ESD) can damage PC boards.

- Put on grounded wrist strap BEFORE handling boards or parts.
- Use proper static-proof bags and boxes to store, move, or ship PC boards.



TILTING OF TRAILER can injure.

- Use tongue jack or blocks to support weight.
- Properly install welding generator onto trailer according to instructions supplied with trailer.

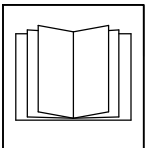

READ INSTRUCTIONS.

- Read and follow all labels and the Owner's Manual carefully before installing, operating, or servicing unit. Read the safety information at the beginning of the manual and in each section.
- Use only genuine replacement parts from the manufacturer.
- Perform maintenance and service according to the Owner's Manuals, industry standards, and national, state, and local codes.

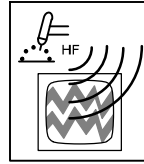

H.F. RADIATION can cause interference.

- High-frequency (H.F.) can interfere with radio navigation, safety services, computers, and communications equipment.
- Have only qualified persons familiar with electronic equipment perform this installation.
- The user is responsible for having a qualified electrician promptly correct any interference problem resulting from the installation.
- If notified by the FCC about interference, stop using the equipment at once.
- Have the installation regularly checked and maintained.
- Keep high-frequency source doors and panels tightly shut, keep spark gaps at correct setting, and use grounding and shielding to minimize the possibility of interference.

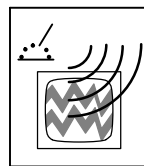

ARC WELDING can cause interference.

- Electromagnetic energy can interfere with sensitive electronic equipment such as micro-processors, computers, and computer-driven equipment such as robots.
- Be sure all equipment in the welding area is electromagnetically compatible.
- To reduce possible interference, keep weld cables as short as possible, close together, and down low, such as on the floor.
- Locate welding operation 100 meters from any sensitive electronic equipment.
- Be sure this welding machine is installed and grounded according to this manual.
- If interference still occurs, the user must take extra measures such as moving the welding machine, using shielded cables, using line filters, or shielding the work area.

1-7. California Proposition 65 Warnings

- ⚠ **Welding or cutting equipment produces fumes or gases which contain chemicals known to the State of California to cause birth defects and, in some cases, cancer. (California Health & Safety Code Section 25249.5 et seq.)**
- ⚠ **Battery posts, terminals and related accessories contain lead and lead compounds, chemicals known to the State of California to cause cancer and birth defects or other reproductive harm. *Wash hands after handling.***
- ⚠ **This product contains chemicals, including lead, known to the state of California to cause cancer, birth defects, or other reproductive harm. *Wash hands after use.***

For Gasoline Engines:

- ⚠ **Engine exhaust contains chemicals known to the State of California to cause cancer, birth defects, or other reproductive harm.**

For Diesel Engines:

- ⚠ **Diesel engine exhaust and some of its constituents are known to the State of California to cause cancer, birth defects, and other reproductive harm.**

1-8. Principal Safety Standards

Safety in Welding, Cutting, and Allied Processes, ANSI Standard Z49.1, from Global Engineering Documents (phone: 1-877-413-5184, website: www.global.ihs.com).

Safe Practices for the Preparation of Containers and Piping for Welding and Cutting, American Welding Society Standard AWS F4.1, from Global Engineering Documents (phone: 1-877-413-5184, website: www.global.ihs.com).

National Electrical Code, NFPA Standard 70, from National Fire Protection Association, Quincy, MA 02269 (phone: 1-800-344-3555, website: www.nfpa.org and www.sparky.org).

Safe Handling of Compressed Gases in Cylinders, CGA Pamphlet P-1, from Compressed Gas Association, 4221 Walney Road, 5th Floor, Chantilly, VA 20151 (phone: 703-788-2700, website: www.cganet.com).

Safety in Welding, Cutting, and Allied Processes, CSA Standard W117.2, from Canadian Standards Association, Standards Sales, 5060 Spectrum Way, Suite 100, Ontario, Canada L4W 5NS (phone: 800-463-6727, website: www.csa-international.org).

Battery Chargers, CSA Standard C22.2 NO 107.2-01, from Canadian Standards Association, Standards Sales, 5060 Spectrum Way, Suite 100, Ontario, Canada L4W 5NS (phone: 800-463-6727, website: www.csa-international.org).

Safe Practice For Occupational And Educational Eye And Face Protection, ANSI Standard Z87.1, from American National Standards Institute,

25 West 43rd Street, New York, NY 10036 (phone: 212-642-4900, website: www.ansi.org).

Standard for Fire Prevention During Welding, Cutting, and Other Hot Work, NFPA Standard 51B, from National Fire Protection Association, Quincy, MA 02269 (phone: 1-800-344-3555, website: www.nfpa.org).

For Standards about hydraulic systems, contact the National Fluid Power Association, Publications Department, 3333 North Mayfair Road, Suite 211, Milwaukee, WI 53222-3219 (phone: (414) 778-3344, website: www.nfpa.com).

OSHA, Occupational Safety and Health Standards for General Industry, Title 29, Code of Federal Regulations (CFR), Part 1910, Subpart Q, and Part 1926, Subpart J, from U.S. Government Printing Office, Superintendent of Documents, P.O. Box 371954, Pittsburgh, PA 15250-7954 (phone: 1-866-512-1800) (there are 10 OSHA Regional Offices—phone for Region 5, Chicago, is 312-353-2220, website: www.osha.gov).

U.S. Consumer Product Safety Commission (CPSC), 4330 East West Highway, Bethesda, MD 20814 (phone: 301-504-7923, website: www.cpsc.gov).

Applications Manual for the Revised NIOSH Lifting Equation, The National Institute for Occupational Safety and Health (NIOSH), 1600 Clifton Rd, Atlanta, GA 30333 (phone: 1-800-232-4636, website: www.cdc.gov/NIOSH).

1-9. EMF Information

Electric current flowing through any conductor causes localized electric and magnetic fields (EMF). Welding current creates an EMF field around the welding circuit and welding equipment. EMF fields may interfere with some medical implants, e.g. pacemakers. Protective measures for persons wearing medical implants have to be taken. For example, access restrictions for passers-by or individual risk assessment for welders. All welders should use the following procedures in order to minimize exposure to EMF fields from the welding circuit:

1. Keep cables close together by twisting or taping them, or using a cable cover.
2. Do not place your body between welding cables. Arrange cables to one side and away from the operator.
3. Do not coil or drape cables around your body.

4. Keep head and trunk as far away from the equipment in the welding circuit as possible.
5. Connect work clamp to workpiece as close to the weld as possible.
6. Do not work next to, sit or lean on the welding power source.
7. Do not weld whilst carrying the welding power source or wire feeder.

About Implanted Medical Devices:

Implanted Medical Device wearers should consult their doctor and the device manufacturer before performing or going near arc welding, spot welding, gouging, plasma arc cutting, or induction heating operations. If cleared by your doctor, then following the above procedures is recommended.

SECTION 2 – CONSIGNES DE SÉCURITÉ – LIRE AVANT UTILISATION

fre_rom_2011-04

! Pour écarter les risques de blessure pour vous-même et pour autrui — lire, appliquer et ranger en lieu sûr ces consignes relatives aux précautions de sécurité et au mode opératoire.

2-1. Signification des symboles



DANGER! – Indique une situation dangereuse qui si on l'évite pas peut donner la mort ou des blessures graves. Les dangers possibles sont montrés par les symboles joints ou sont expliqués dans le texte.



Indique une situation dangereuse qui si on l'évite pas peut donner la mort ou des blessures graves. Les dangers possibles sont montrés par les symboles joints ou sont expliqués dans le texte.

NOTE – Indique des déclarations pas en relation avec des blessures personnelles.

Indique des instructions spécifiques.



Ce groupe de symboles veut dire Avertissement! Attention! DANGER DE CHOC ELECTRIQUE, PIECES EN MOUVEMENT, et PIECES CHAUDES. Consulter les symboles et les instructions ci-dessous y afférant pour les actions nécessaires afin d'éviter le danger.

2-2. Dangers relatifs au soudage à l'arc



Les symboles présentés ci-après sont utilisés tout au long du présent manuel pour attirer votre attention et identifier les risques de danger. Lorsque vous voyez un symbole, soyez vigilant et suivez les directives mentionnées afin d'éviter tout danger. Les consignes de sécurité présentées ci-après ne font que résumer l'information contenue dans les normes de sécurité énumérées à la section 1-8. Veuillez lire et respecter toutes ces normes de sécurité.



L'installation, l'utilisation, l'entretien et les réparations ne doivent être confiés qu'à des personnes qualifiées.



Au cours de l'utilisation, tenir toute personne à l'écart et plus particulièrement les enfants.



UN CHOC ÉLECTRIQUE peut tuer.

Un simple contact avec des pièces électriques peut provoquer une électrocution ou des blessures graves. L'électrode et le circuit de soudage sont sous tension dès que l'appareil est sur ON. Le circuit d'entrée et les circuits internes de l'appareil sont également sous tension à ce moment-là. En soudage semi-automatique ou automatique, le fil, le dévidoir, le logement des galets d'entraînement et les pièces métalliques en contact avec le fil de soudage sont sous tension. Des matériels mal installés ou mal mis à la terre présentent un danger.

- Ne jamais toucher les pièces électriques sous tension.
- Porter des gants et des vêtements de protection secs ne comportant pas de trous.
- S'isoler de la pièce et de la terre au moyen de tapis ou d'autres moyens isolants suffisamment grands pour empêcher le contact physique éventuel avec la pièce ou la terre.
- Ne pas se servir de source électrique à courant électrique dans les zones humides, dans les endroits confinés ou là où on risque de tomber.
- Se servir d'une source électrique à courant électrique UNIQUEMENT si le procédé de soudage le demande.
- Si l'utilisation d'une source électrique à courant électrique s'avère nécessaire, se servir de la fonction de télécommande si l'appareil en est équipé.
- Des précautions de sécurité supplémentaires sont requises dans des environnements à risque comme: les endroits humides ou lorsque l'on porte des vêtements mouillés; sur des structures métalliques au sol, grillages et échafaudages; dans des positions assises, à genoux et allongées; ou quand il y a un risque important de contact accidentel avec la pièce ou le sol. Dans ces cas utiliser les appareils suivants dans l'ordre de préférence: 1) un poste à souder DC semi-automatique de type CV (MIG/MAG), 2) un poste à souder manuel (électrode enrobée) DC, 3) un poste à souder manuel AC avec tension à vide réduite. Dans la plupart des cas, un poste courant continu de type CV est recommandé. Et, ne pas travailler seul!
- Couper l'alimentation ou arrêter le moteur avant de procéder à l'installation, à la réparation ou à l'entretien de l'appareil. Déverrouiller l'alimentation selon la norme OSHA 29 CFR 1910.147 (voir normes de sécurité).
- Installez, mettez à la terre et utilisez correctement cet équipement conformément à son Manuel d'Utilisation et aux réglementations nationales, gouvernementales et locales.
- Installer et mettre à la terre correctement cet appareil conformément à son manuel d'utilisation et aux codes nationaux, provinciaux et municipaux.
- Toujours vérifier la terre du cordon d'alimentation – Vérifier et s'assurer que le fil de terre du cordon d'alimentation est bien raccordé à la borne de terre du sectionneur ou que la fiche du cordon est raccordée à une prise correctement mise à la terre.
- En effectuant les raccordements d'entrée fixer d'abord le conducteur de mise à la terre approprié et contre-vérifier les connexions.
- Les câbles doivent être exempts d'humidité, d'huile et de graisse; protégez-les contre les étincelles et les pièces métalliques chaudes.
- Vérifier fréquemment le cordon d'alimentation pour voir s'il n'est pas endommagé ou dénudé – remplacer le cordon immédiatement s'il est endommagé – un câble dénudé peut provoquer une électrocution.
- Mettre l'appareil hors tension quand on ne l'utilise pas.
- Ne pas utiliser des câbles usés, endommagés, de grosseur insuffisante ou mal épissés.
- Ne pas enrouler les câbles autour du corps.
- Si la pièce soudée doit être mise à la terre, le faire directement avec un câble distinct – ne pas utiliser le connecteur de pièce ou le câble de retour.
- Ne pas toucher l'électrode quand on est en contact avec la pièce, la terre ou une électrode provenant d'une autre machine.
- Ne pas toucher des porte électrodes connectés à deux machines en même temps à cause de la présence d'une tension à vide doublée.
- N'utiliser qu'un matériel en bon état. Réparer ou remplacer sur-le-champ les pièces endommagées. Entretien l'appareil conformément à ce manuel.
- Porter un harnais de sécurité quand on travaille en hauteur.
- Maintenir solidement en place tous les panneaux et capots.
- Fixer le câble de retour de façon à obtenir un bon contact métal-métal avec la pièce à souder ou la table de travail, le plus près possible de la soudure.
- Isoler la pince de masse quand pas mis à la pièce pour éviter le contact avec tout objet métallique.

Il reste une TENSION DC NON NÉGLIGEABLE dans les sources de soudage onduleur UNE FOIS le moteur coupé.

- Couper l'alimentation du poste et décharger les condensateurs d'entrée comme indiqué dans la Section Maintenance avant de toucher des composants.



LES PIÈCES CHAUDES peuvent provoquer des brûlures.

- Ne pas toucher à mains nues les parties chaudes.
- Prévoir une période de refroidissement avant de travailler à l'équipement.
- Ne pas toucher aux pièces chaudes, utiliser les outils recommandés et porter des gants de soudage et des vêtements épais pour éviter les brûlures.

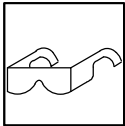

DES PIÈCES DE METAL ou DES SALETES peuvent provoquer des blessures dans les yeux.

- Le soudage, l'écaillage, le passage de la pièce à la brosse en fil de fer, et le meulage génèrent des étincelles et des particules métalliques volantes. Pendant la période de refroidissement des soudures, elles risquent de projeter du laitier.
- Porter des lunettes de sécurité avec écrans latéraux ou un écran facial.



LES FUMÉES ET LES GAZ peuvent être dangereux.

Le soudage génère des fumées et des gaz. Leur inhalation peut être dangereux pour votre santé.

- Eloigner votre tête des fumées. Ne pas respirer les fumées.
- À l'intérieur, ventiler la zone et/ou utiliser une ventilation forcée au niveau de l'arc pour l'évacuation des fumées et des gaz de soudage.
- Si la ventilation est médiocre, porter un respirateur anti-vapeurs approuvé.
- Lire et comprendre les spécifications de sécurité des matériaux (MSDS) et les instructions du fabricant concernant les métaux, les consommables, les revêtements, les nettoyants et les dégraissages.
- Travailler dans un espace fermé seulement s'il est bien ventilé ou en portant un respirateur à alimentation d'air. Demander toujours à un surveillant dûment formé de se tenir à proximité. Des fumées et des gaz de soudage peuvent déplacer l'air et abaisser le niveau d'oxygène provoquant des blessures ou des accidents mortels. S'assurer que l'air de respiration ne présente aucun danger.
- Ne pas souder dans des endroits situés à proximité d'opérations de dégraissage, de nettoyage ou de pulvérisation. La chaleur et les rayons de l'arc peuvent réagir en présence de vapeurs et former des gaz hautement toxiques et irritants.
- Ne pas souder des métaux munis d'un revêtement, tels que l'acier galvanisé, plaqué en plomb ou au cadmium à moins que le revêtement n'ait été enlevé dans la zone de soudure, que l'endroit soit bien ventilé, et en portant un respirateur à alimentation d'air. Les revêtements et tous les métaux renfermant ces éléments peuvent dégager des fumées toxiques en cas de soudage.



LES ACCUMULATIONS DE GAZ risquent de provoquer des blessures ou même la mort.

- Fermer l'alimentation du gaz protecteur en cas de non utilisation.
- Veiller toujours à bien aérer les espaces confinés ou se servir d'un respirateur d'adduction d'air homologué.

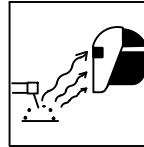

LES RAYONS DE L'ARC peuvent provoquer des brûlures dans les yeux et sur la peau.

Le rayonnement de l'arc du procédé de soudage génère des rayons visibles et invisibles intenses (ultraviolets et infrarouges) susceptibles de provoquer des brûlures dans les yeux et sur la peau. Des étincelles sont projetées pendant le soudage.

- Porter un casque de soudage approuvé muni de verres filtrants appropriés pour protéger visage et yeux pour protéger votre visage et vos yeux pendant le soudage ou pour regarder (voir ANSI Z49.1 et Z87.1 énuméré dans les normes de sécurité).
- Porter des lunettes de sécurité avec écrans latéraux même sous votre casque.
- Avoir recours à des écrans protecteurs ou à des rideaux pour protéger les autres contre les rayonnements les éblouissements et les étincelles ; prévenir toute personne sur les lieux de ne pas regarder l'arc.
- Porter des vêtements confectionnés avec des matières résistantes et ignifuges (cuir, coton lourd ou laine) et des bottes de protection.

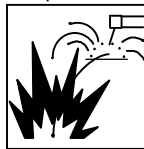

LE SOUDAGE peut provoquer un incendie ou une explosion.

Le soudage effectué sur des conteneurs fermés tels que des réservoirs, tambours ou des conduites peut provoquer leur éclatement. Des étincelles peuvent être projetées de l'arc de soudure. La projection d'étincelles, des pièces chaudes et des équipements chauds peut provoquer des incendies et des brûlures. Le contact accidentel de l'électrode avec des objets métalliques peut provoquer des étincelles, une explosion, un surchauffement ou un incendie. Avant de commencer le soudage, vérifier et s'assurer que l'endroit ne présente pas de danger.

- Déplacer toutes les substances inflammables à une distance de 10,7 m de l'arc de soudage. En cas d'impossibilité les recouvrir soigneusement avec des protections homologués.
- Ne pas souder dans un endroit où des étincelles peuvent tomber sur des substances inflammables.
- Se protéger et d'autres personnes de la projection d'étincelles et de métal chaud.
- Des étincelles et des matériaux chauds du soudage peuvent facilement passer dans d'autres zones en traversant de petites fissures et des ouvertures.
- Surveiller tout déclenchement d'incendie et tenir un extincteur à proximité.
- Le soudage effectué sur un plafond, plancher, paroi ou séparation peut déclencher un incendie de l'autre côté.
- Ne pas effectuer le soudage sur des conteneurs fermés tels que des réservoirs, tambours, ou conduites, à moins qu'ils n'aient été préparés correctement conformément à AWS F4.1 (voir les normes de sécurité).
- Ne soudez pas si l'air ambiant est chargé de particules, gaz, ou vapeurs inflammables (vapeur d'essence, par exemple).
- Brancher le câble de masse sur la pièce la plus près possible de la zone de soudage pour éviter le transport du courant sur une longue distance par des chemins inconnus éventuels en provoquant des risques d'électrocution, d'étincelles et d'incendie.
- Ne pas utiliser le poste de soudage pour dégelé des conduites gelées.
- En cas de non utilisation, enlever la baguette d'électrode du porte-électrode ou couper le fil à la pointe de contact.
- Porter des vêtements de protection dépourvus d'huile tels que des gants en cuir, une chemise en matériau lourd, des pantalons sans revers, des chaussures hautes et un couvre chef.
- Avant de souder, retirer toute substance combustible de vos poches telles qu'un allumeur au butane ou des allumettes.
- Une fois le travail achevé, assurez-vous qu'il ne reste aucune trace d'étincelles incandescentes ni de flammes.
- Utiliser exclusivement des fusibles ou coupe-circuits appropriés. Ne pas augmenter leur puissance; ne pas les porter.
- Suivre les recommandations dans OSHA 1910.252(a)(2)(iv) et NFPA 51B pour les travaux à chaud et avoir de la surveillance et un extincteur à proximité.

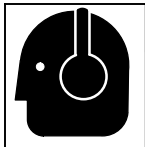

LE BRUIT peut affecter l'ouïe.

Le bruit des processus et des équipements peut affecter l'ouïe.

- Porter des protections approuvés pour les oreilles si le niveau sonore est trop élevé.



Les CHAMPS ÉLECTROMAGNÉTIQUES (CEM) peuvent affecter les implants médicaux.

- Les porteurs de stimulateurs cardiaques et autres implants médicaux doivent rester à distance.
- Les porteurs d'implants médicaux doivent consulter leur médecin et le fabricant du dispositif avant de s'approcher de la zone où se déroule du soudage à l'arc, du soudage par points, du gougeage, de la découpe plasma ou une opération de chauffage par induction.

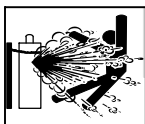

Si des BOUTEILLES sont endommagées, elles pourront exploser.

Des bouteilles de gaz protecteur contiennent du gaz sous haute pression. Si une bouteille est endommagée, elle peut exploser. Du fait que les bouteilles de gaz font normalement partie du procédé de soudage, les manipuler avec précaution.

- Protéger les bouteilles de gaz comprimé d'une chaleur excessive, des chocs mécaniques, des dommages physiques, du laitier, des flammes ouvertes, des étincelles et des arcs.
- Placer les bouteilles debout en les fixant dans un support stationnaire ou dans un porte-bouteilles pour les empêcher de tomber ou de se renverser.
- Tenir les bouteilles éloignées des circuits de soudage ou autres circuits électriques.
- Ne jamais placer une torche de soudage sur une bouteille à gaz.
- Une électrode de soudage ne doit jamais entrer en contact avec une bouteille.
- Ne jamais souder une bouteille pressurisée – risque d'explosion.
- Utiliser seulement des bouteilles de gaz protecteur, régulateurs, tuyaux et raccords convenables pour cette application spécifique; les maintenir ainsi que les éléments associés en bon état.
- Ne pas tenir la tête en face de la sortie en ouvrant la soupape de la bouteille.
- Maintenir le chapeau de protection sur la soupape, sauf en cas d'utilisation ou de branchement de la bouteille.
- Utiliser les équipements corrects, les bonnes procédures et suffisamment de personnes pour soulever et déplacer les bouteilles.
- Lire et suivre les instructions sur les bouteilles de gaz comprimé, l'équipement connexe et le dépliant P-1 de la CGA (Compressed Gas Association) mentionné dans les principales normes de sécurité.

2-3. Dangers existant en relation avec le moteur

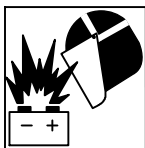

L'EXPLOSION DE LA BATTERIE peut provoquer des blessures.

- Toujours porter une protection faciale, des gants en caoutchouc et vêtements de protection lors d'une intervention sur la batterie.
- Arrêter le moteur avant de débrancher ou de brancher des câbles de batterie, des câbles de chargeur de batterie (le cas échéant) ou de batterie d'entretien.
- Éviter de provoquer des étincelles avec les outils en travaillant sur la batterie.
- Ne pas utiliser l'appareil de soudage pour charger des batteries ou faire démarrer des véhicules à l'aide de câbles de démarrage, sauf si l'appareil dispose d'une fonctionnalité de charge de batterie destinée à cet usage.
- Observer la polarité correcte (+ et -) sur les batteries.
- Débrancher le câble négatif (-) en premier lieu. Le rebrancher en dernier lieu.
- Les sources d'étincelles, flammes nues, cigarettes et autres sources d'inflammation doivent être maintenues à l'écart des batteries. Ces dernières produisent des gaz explosifs en fonctionnement normal et en cours de charge.
- Respecter les consignes du fabricant de la batterie pour travailler sur une batterie ou à proximité.

Le COURANT DE CHARGE DE BATTERIE peut provoquer des blessures (la fonctionnalité de charge de batterie n'est pas disponible sur tous les modèles).

- Les opérations de charge de batterie ne doivent être effectuées que par des personnes qualifiées.
- Ne charger que des batteries plomb-acide. Ne pas utiliser le chargeur de batterie pour alimenter un autre circuit électrique basse tension ou pour charger des batteries sèches.
- Ne pas charger une batterie gelée.
- Ne pas utiliser de câbles de charge endommagés.
- Ne pas charger une batterie dont les bornes sont desserrées ou présentant une détérioration comme par exemple un boîtier ou un couvercle fissuré.
- Avant de charger une batterie, sélectionner la tension de charge correspondant à la tension de la batterie.

- Régler les commandes de charge de batterie sur la position d'arrêt avant de brancher la batterie. Veiller à ce que les pinces de charge ne se touchent pas.
- Ranger les câbles de charge à distance du capot, des portes et des pièces mobiles du véhicule.



LE CARBURANT MOTEUR peut provoquer un incendie ou une explosion.

- Arrêter le moteur avant de vérifier le niveau de carburant ou de faire le plein.
- Ne pas faire le plein en fumant ou proche d'une source d'étincelles ou d'une flamme nue.
- Ne pas faire le plein de carburant à ras bord; prévoir de l'espace pour son expansion.
- Faire attention de ne pas renverser de carburant. Nettoyer tout carburant renversé avant de faire démarrer le moteur.
- Jeter les chiffons dans un récipient ignifuge.
- Toujours garder le pistolet en contact avec le réservoir lors du remplissage.



Les PIÈCES MOBILES peuvent causer des blessures.

- S'abstenir de toucher des parties mobiles telles que des ventilateurs, courroies et rotors.
- Maintenir fermés et verrouillés les portes, panneaux, recouvrements et dispositifs de protection.
- Arrêter le moteur avant d'installer ou de brancher l'appareil.
- Lorsque cela est nécessaire pour des travaux d'entretien et de dépannage, faire retirer les portes, panneaux, recouvrements ou dispositifs de protection uniquement par du personnel qualifié.
- Pour empêcher tout démarrage accidentel pendant les travaux d'entretien, débrancher le câble négatif (-) de batterie de la borne.
- Ne pas approcher les mains, cheveux, vêtements lâches et outils des organes mobiles.
- Remettre en place les portes, panneaux, recouvrements ou dispositifs de protection à la fin des travaux d'entretien et avant de mettre le moteur en marche.
- Avant d'intervenir, déposer les bougies ou injecteurs pour éviter la mise en route accidentelle du moteur.
- Bloquer le volant moteur pour éviter sa rotation lors d'une intervention sur le générateur.



LES ÉTINCELLES À L'ÉCHAPPEMENT peuvent provoquer un incendie.

- Empêcher les étincelles d'échappement du moteur de provoquer un incendie.
- Utiliser uniquement un pare-étincelles approuvé – voir codes en vigueur.



LES PIÈCES CHAUDES peuvent provoquer des brûlures.

- Ne pas toucher des parties chaudes à mains nues.
- Prévoir une période de refroidissement avant de travailler à l'équipement.
- Ne pas toucher aux pièces chaudes, utiliser les outils recommandés et porter des gants de soudage et des vêtements épais pour éviter les brûlures.



LA VAPEUR ET LE LIQUIDE DE REFROIDISSEMENT CHAUD peuvent provoquer des brûlures.

- Il est préférable de vérifier le liquide de refroidissement une fois le moteur refroidi pour éviter de se brûler.
- Toujours vérifier le niveau de liquide de refroidissement dans le vase d'expansion (si présent), et non dans le radiateur (sauf si précisé autrement dans la section maintenance du manuel du moteur).
- Si le moteur est chaud et que le liquide doit être vérifié, opérer comme suivant.

2-4. Dangers liés à l'hydraulique

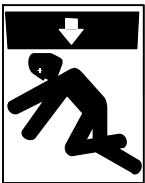

Les ÉQUIPEMENTS HYDRAULIQUES peuvent provoquer des blessures ou même la mort.

- Une installation ou une utilisation incorrecte de cet appareil pourrait conduire à des dégâts matériels ou corporels. Seul un personnel qualifié est autorisé à installer, faire fonctionner et réparer cet appareil conformément à son manuel d'utilisation, aux normes industrielles et aux codes nationaux, d'état ou locaux.
- Ne pas dépasser le débit nominal ou la capacité de la pompe hydraulique ou de tout équipement du circuit hydraulique. Concevoir le circuit hydraulique de telle sorte que la défaillance d'un composant hydraulique ne risque pas de provoquer un accident matériel ou corporel.
- Avant d'intervenir sur le circuit hydraulique, couper l'alimentation électrique, verrouiller et étiqueter l'appareil, détendre la pression et s'assurer que le circuit hydraulique ne peut être remis sous pression par inadvertance.
- Ne pas intervenir sur le circuit hydraulique lorsque l'appareil fonctionne. Seul un personnel qualifié et appliquant les consignes du fabricant est autorisé le faire.
- Ne pas modifier ou altérer la pompe hydraulique ou les équipements fournis par le fabricant. Ne pas débrancher, désactiver ou neutraliser les équipements de sécurité du circuit hydraulique.
- Utiliser uniquement des composants et accessoires homologués par le fabricant.
- Se tenir à l'écart de tout point présentant un danger de pincement ou d'écrasement créé par l'équipement raccordé au circuit hydraulique.
- Ne pas intervenir sous ou autour d'un équipement qui n'est soutenu que par la pression hydraulique. Soutenir l'équipement de façon appropriée par un moyen mécanique.

- Mettre des lunettes de sécurité et des gants, placer un torchon sur le bouchon du radiateur.
- Dévisser le bouchon légèrement et laisser la vapeur s'échapper avant d'enlever le bouchon.

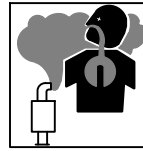

L'utilisation d'un groupe autonome à l'intérieur PEUT VOUS TUER EN QUELQUES MINUTES.

- Les fumées d'un groupe autonome contient du monoxyde de carbone. C'est un poison invisible et inodore.
- JAMAIS utiliser dans une maison ou garage, même avec les portes et fenêtres ouvertes.
- Uniquement utiliser à l'EXTERIEUR, loin des portes, fenêtres et bouches aération.

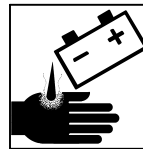

L'ACIDE DE LA BATTERIE peut provoquer des brûlures dans les YEUX et sur la PEAU.

- Ne pas renverser la batterie.
- Remplacer une batterie endommagée.
- Rincer immédiatement les yeux et la peau à l'eau.



LA CHALEUR DU MOTEUR peut provoquer un incendie.

- Ne pas placer l'appareil sur, au-dessus ou à proximité de surfaces inflammables.
- Tenir à distance les produits inflammables de l'échappement.



Le LIQUIDE HYDRAULIQUE risque de provoquer des blessures ou même la mort.

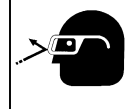

- Avant d'intervenir sur le circuit hydraulique, couper l'alimentation électrique, verrouiller et étiqueter l'appareil, détendre la pression et s'assurer que le circuit hydraulique ne peut être remis sous pression par inadvertance.
- Détendre la pression avant de débrancher ou de brancher des canalisations hydrauliques.
- Avant d'utiliser l'appareil, contrôler les composants du circuit hydraulique, les branchements et les flexibles en recherchant tout signe de détérioration, de fuite et d'usure.
- Pour intervenir sur un circuit hydraulique, porter un équipement de protection tel que des lunettes de sécurité, des gants de cuir, une chemise et un pantalon en tissu résistant, des chaussures montantes et une coiffe.
- Pour rechercher des fuites, utiliser un morceau de papier ou de carton, jamais les mains nues. En cas de détection de fuite, ne pas utiliser l'équipement.
- Le LIQUIDE HYDRAULIQUE est INFLAMMABLE. Ne pas intervenir sur des composants hydrauliques à proximité d'étincelles ou de flammes; ne pas fumer à proximité de liquide hydraulique.
- Remettre les portes, panneaux, recouvrements ou dispositifs de protection quand l'entretien est terminé et avant de mettre en marche l'appareil.
- En cas de pénétration d'un QUELCONQUE liquide dans la peau, celui-ci doit être retiré chirurgicalement sous quelques heures par un médecin familiarisé avec ce type de blessure, faute de quoi la gangrène pourrait apparaître.



Les PIÈCES MOBILES peuvent causer des blessures.

- S'abstenir de toucher des parties mobiles telles que des ventilateurs, courroies et rotors.
- Maintenir fermés et verrouillés les portes, panneaux, recouvrements et dispositifs de protection.
- Ne pas approcher les mains, cheveux, vêtements lâches et outils des organes mobiles.
- Avant d'intervenir sur le circuit hydraulique, couper l'alimentation électrique, verrouiller et étiqueter l'appareil, détendre la pression et s'assurer que le circuit hydraulique ne peut être remis sous pression par inadvertance.
- Demander seulement à un personnel qualifié d'enlever les dispositifs de sécurité ou les recouvrements pour effectuer, s'il y a lieu, des travaux d'entretien et de dépannage.
- Remettre en place les portes, panneaux, recouvrements ou dispositifs de protection à la fin des travaux d'entretien et avant de mettre le moteur en marche.



LES PIÈCES ET LIQUIDES CHAUDS peuvent provoquer des brûlures.

- Ne pas toucher les pièces chaudes à main nue ni laisser des liquides chauds entrer en contact avec la peau.
- Prévoir une période de refroidissement avant d'intervenir sur l'équipement.
- Ne pas toucher aux pièces chaudes, utiliser les outils recommandés et porter des gants de soudage et des vêtements épais pour éviter les brûlures.

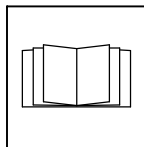

LIRE LES INSTRUCTIONS.

- Lire et appliquer les instructions sur les étiquettes et le Mode d'emploi avant l'installation, l'utilisation ou l'entretien de l'appareil. Lire les informations de sécurité au début du manuel et dans chaque section.
- N'utiliser que les pièces de rechange recommandées par le constructeur.
- Effectuer l'entretien en respectant les manuels d'utilisation, les normes industrielles et les codes nationaux, d'état et locaux.

2-5. Dangers liés à l'air comprimé



Un ÉQUIPEMENT PNEUMATIQUE risque de provoquer des blessures ou même la mort.

- Une installation ou une utilisation incorrecte de cet appareil pourrait conduire à des dégâts matériels ou corporels. Seul un personnel qualifié est autorisé à installer, utiliser et entretenir cet appareil conformément à son manuel d'utilisation, aux normes industrielles et aux codes nationaux, d'état ou locaux.
- Ne pas dépasser le débit nominal ou la capacité du compresseur ou de tout équipement du circuit d'air comprimé. Concevoir le circuit d'air comprimé de telle sorte que la défaillance d'un composant ne risque pas de provoquer un accident matériel ou corporel.
- Avant d'intervenir sur le circuit d'air comprimé, couper l'alimentation électrique, verrouiller et étiqueter l'appareil, détendre la pression et s'assurer que le circuit d'air ne peut être mis sous pression par inadvertance.
- Ne pas intervenir sur le circuit d'air comprimé lorsque l'appareil fonctionne. Seul un personnel qualifié est autorisé, et appliquant les consignes du fabricant.
- Ne pas modifier ou altérer le compresseur ou les équipements fournis par le fabricant. Ne pas débrancher, désactiver ou neutraliser les équipements de sécurité du circuit d'air comprimé.
- Utiliser uniquement des composants et accessoires homologués par le fabricant.
- Se tenir à l'écart de tout point présentant un danger de pincement ou d'écrasement créé par l'équipement raccordé au circuit d'air comprimé.
- Ne pas intervenir sous ou autour d'un équipement qui n'est soutenu que par la pression pneumatique. Soutenir l'équipement de façon appropriée par un moyen mécanique.



L'AIR COMPRIMÉ risque de provoquer des blessures ou même la mort.

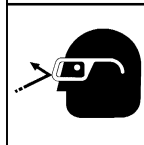

- Avant d'intervenir sur le circuit d'air comprimé, couper l'alimentation électrique, verrouiller et étiqueter l'appareil, détendre la pression et s'assurer que le circuit d'air ne peut être mis sous pression par inadvertance.
- Détendre la pression avant de débrancher ou de brancher des canalisations d'air.
- Avant d'utiliser l'appareil, contrôler les composants du circuit d'air comprimé, les branchements et les flexibles en recherchant tout signe de détérioration, de fuite et d'usure.
- Ne pas diriger un jet d'air vers soi-même ou vers autrui.
- Pour intervenir sur un circuit d'air comprimé, porter un équipement de protection tel que des lunettes de sécurité, des gants de cuir, une chemise et un pantalon en tissu résistant, des chaussures montantes et une coiffe.
- Pour rechercher des fuites, utiliser de l'eau savonneuse ou un détecteur à ultrasons, jamais les mains nues. En cas de détection de fuite, ne pas utiliser l'équipement.
- Remettre les portes, panneaux, recouvrements ou dispositifs de protection quand l'entretien est terminé et avant de mettre en marche l'appareil.
- En cas d'injection d'air dans la peau ou le corps, demander immédiatement une assistance médicale.



MÉTAL CHAUD provenant du découpage ou du gougeage à l'arc risque de provoquer un incendie ou une explosion.

- Ne pas découper ou gouger à proximité de produits inflammables.
- Attention aux risques d'incendie: tenir un extincteur à proximité.



L'INHALATION D'AIR COMPRIMÉ risque de provoquer des blessures ou même la mort.

- Ne pas inhaler d'air comprimé.
- Utiliser l'air comprimé uniquement pour découper ou gouger ainsi que pour l'outillage pneumatique.



Une **PRESSION D'AIR RÉSIDUELLE** ET DES **FLEXIBLES QUI FOUETTENT** risquent de provoquer des blessures.

- Détendre la pression pneumatique des outils et circuits avant d'entretenir, ajouter ou changer des accessoires et avant d'ouvrir le bouchon de vidange ou de remplissage d'huile du compresseur.



Les **PIÈCES MOBILES** peuvent causer des blessures.

- S'abstenir de toucher des parties mobiles telles que des ventilateurs, courroies et rotors.
- Maintenir fermés et verrouillés les portes, panneaux, recouvrements et dispositifs de protection.

- Ne pas approcher les mains, cheveux, vêtements lâches et outils des organes mobiles.
- Avant d'intervenir sur le circuit d'air comprimé, couper l'alimentation électrique, verrouiller et étiqueter l'appareil, détendre la pression et s'assurer que le circuit d'air ne peut être mis sous pression par inadvertance.
- Demander seulement à un personnel qualifié d'enlever les dispositifs de sécurité ou les recouvrements pour effectuer, s'il y a lieu, des travaux d'entretien et de dépannage.

- Remettre en place les portes, panneaux, recouvrements ou dispositifs de protection à la fin des travaux d'entretien et avant de mettre le moteur en marche.



DES **PIÈCES CHAUDES** peuvent provoquer des brûlures graves.

- Ne pas toucher de pièces chaudes du compresseur ou du circuit d'air.
- Prévoir une période de refroidissement avant d'intervenir sur l'équipement.
- Ne pas toucher aux pièces chaudes, utiliser les outils recommandés et porter des gants de soudage et des vêtements épais pour éviter les brûlures.

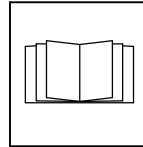

LIRE LES INSTRUCTIONS.

- Lire et appliquer les instructions sur les étiquettes et le Mode d'emploi avant l'installation, l'utilisation ou l'entretien de l'appareil. Lire les informations de sécurité au début du manuel et dans chaque section.
- N'utiliser que les pièces de rechange recommandées par le constructeur.
- Effectuer l'entretien en respectant les manuels d'utilisation, les normes industrielles et les codes nationaux, d'état et locaux.

2-6. Dangers supplémentaires en relation avec l'installation, le fonctionnement et la maintenance



Risque D'INCENDIE OU D'EXPLOSION.

- Ne pas placer l'appareil sur, au-dessus ou à proximité de surfaces inflammables.
- Ne pas installer l'appareil à proximité de produits inflammables.
- Ne pas surcharger l'installation électrique – s'assurer que l'alimentation est correctement dimensionnée et protégée avant de mettre l'appareil en service.

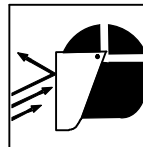

LES **ÉTINCELLES PROJETÉES** peuvent provoquer des blessures.

- Porter un écran facial pour protéger le visage et les yeux.
- Affûter l'électrode au tungstène uniquement à la meuleuse dotée de protecteurs. Cette manœuvre est à exécuter dans un endroit sûr lorsque l'on porte l'équipement homologué de protection du visage, des mains et du corps.
- Les étincelles risquent de causer un incendie – éloigner toute substance inflammable.



LA **CHUTE DE L'ÉQUIPEMENT** peut provoquer des blessures.

- Utiliser l'anneau de levage pour lever l'appareil et les accessoires correctement installés seuls, PAS les bouteilles de gaz. Ne pas dépasser le poids nominal maximal de l'ocillon (voir les spécifications).
- Utiliser un équipement de levage de capacité suffisante pour lever l'appareil.
- En utilisant des fourches de levage pour déplacer l'unité, s'assurer que les fourches sont suffisamment longues pour dépasser du côté opposé de l'appareil.
- Tenir l'équipement (câbles et cordons) à distance des véhicules mobiles lors de toute opération en hauteur.
- Suivre les consignes du Manuel des applications pour l'équation de levage NIOSH révisée (Publication N°94-110) lors du levage manuel de pièces ou équipements lourds.



Les **PIÈCES MOBILES** peuvent causer des blessures.

- Ne pas s'approcher des organes mobiles.
- Ne pas s'approcher des points de coincement tels que des rouleaux de commande.

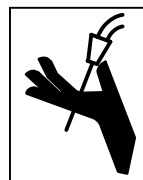

LES **FILS DE SOUDAGE** peuvent provoquer des blessures.

- Ne pas appuyer sur la gâchette avant d'en avoir reçu l'instruction.
- Ne pas diriger le pistolet vers soi, d'autres personnes ou toute pièce mécanique en engageant le fil de soudage.

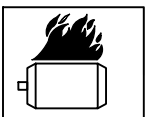

LE **SURCHAUFFEMENT** peut endommager le moteur électrique.

- Arrêter ou déconnecter l'équipement avant de démarrer ou d'arrêter le moteur.
- Ne pas laisser tourner le moteur trop lentement sous risque d'endommager le moteur électrique à cause d'une tension et d'une fréquence trop faibles.
- Ne pas brancher de moteur de 50 ou de 60 Hz à la prise de 100 Hz, s'il y a lieu.

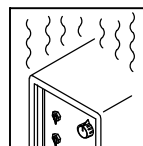

L'EMPLOI EXCESSIF peut SURCHAUFFER L'ÉQUIPEMENT.

- Laisser l'équipement refroidir ; respecter le facteur de marche nominal.
- Réduire le courant ou le facteur de marche avant de poursuivre le soudage.
- Ne pas obstruer les passages d'air du poste.



LES CHARGES ÉLECTROSTATIQUES peuvent endommager les circuits imprimés.

- Établir la connexion avec la barrette de terre avant de manipuler des cartes ou des pièces.
- Utiliser des pochettes et des boîtes antistatiques pour stocker, déplacer ou expédier des cartes de circuits imprimés.



UNE REMORQUE QUI BASCULE peut provoquer des blessures.

- Utiliser les supports de la remorque ou des blocs pour soutenir le poids.
- Installer convenablement le poste sur la remorque comme indiqué dans le manuel s'y rapportant.

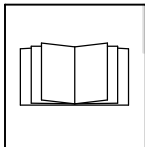

LIRE LES INSTRUCTIONS.

- Lire et appliquer les instructions sur les étiquettes et le Mode d'emploi avant l'installation, l'utilisation ou l'entretien de l'appareil. Lire les informations de sécurité au début du manuel et dans chaque section.
- N'utiliser que les pièces de rechange recommandées par le constructeur.
- Effectuer l'entretien en respectant les manuels d'utilisation, les normes industrielles et les codes nationaux, d'état et locaux.

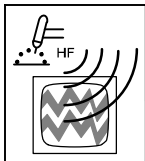

LE RAYONNEMENT HAUTE FRÉQUENCE (H.F.) risque de provoquer des interférences.

- Le rayonnement haute fréquence (H.F.) peut provoquer des interférences avec les équipements de radio-navigation et de communication, les services de sécurité et les ordinateurs.

- Demander seulement à des personnes qualifiées familiarisées avec des équipements électroniques de faire fonctionner l'installation.
- L'utilisateur est tenu de faire corriger rapidement par un électricien qualifié les interférences résultant de l'installation.
- Si le FCC signale des interférences, arrêter immédiatement l'appareil.
- Effectuer régulièrement le contrôle et l'entretien de l'installation.
- Maintenir soigneusement fermés les portes et les panneaux des sources de haute fréquence, maintenir les éclateurs à une distance correcte et utiliser une terre et un blindage pour réduire les interférences éventuelles.

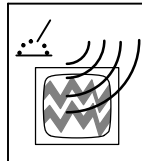

LE SOUDAGE À L'ARC risque de provoquer des interférences.

- L'énergie électromagnétique risque de provoquer des interférences pour l'équipement électronique sensible tel que les ordinateurs et l'équipement commandé par ordinateur tel que les robots.
- Veiller à ce que tout l'équipement de la zone de soudage soit compatible électromagnétiquement.
- Pour réduire la possibilité d'interférence, maintenir les câbles de soudage aussi courts que possible, les grouper, et les poser aussi bas que possible (ex. par terre).
- Veiller à souder à une distance de 100 mètres de tout équipement électronique sensible.
- Veiller à ce que ce poste de soudage soit posé et mis à la terre conformément à ce mode d'emploi.
- En cas d'interférences après avoir pris les mesures précédentes, il incombe à l'utilisateur de prendre des mesures supplémentaires telles que le déplacement du poste, l'utilisation de câbles blindés, l'utilisation de filtres de ligne ou la pose de protecteurs dans la zone de travail.

2-7. Proposition californienne 65 Avertissements

! Les équipements de soudage et de coupage produisent des fumées et des gaz qui contiennent des produits chimiques dont l'État de Californie reconnaît qu'ils provoquent des malformations congénitales et, dans certains cas, des cancers. (Code de santé et de sécurité de Californie, chapitre 25249.5 et suivants)

! Les batteries, les bornes et autres accessoires contiennent du plomb et des composés à base de plomb, produits chimiques dont l'État de Californie reconnaît qu'ils provoquent des cancers et des malformations congénitales ou autres problèmes de procréation. *Se laver les mains après manipulation.*

! Ce produit contient des produits chimiques, notamment du plomb, dont l'État de Californie reconnaît qu'ils provoquent des cancers, des malformations congénitales ou d'autres problèmes de procréation. *Se laver les mains après utilisation.*

Pour les moteurs à essence :

! Les gaz d'échappement des moteurs contiennent des produits chimiques dont l'État de Californie reconnaît qu'ils provoquent des cancers et des malformations congénitales ou autres problèmes de procréation.

Pour les moteurs diesel :

! Les gaz d'échappement des moteurs diesel et certains de leurs composants sont reconnus par l'État de Californie comme provoquant des cancers et des malformations congénitales ou autres problèmes de procréation.

2-8. Principales normes de sécurité

Safety in Welding, Cutting, and Allied Processes, ANSI Standard Z49.1, from Global Engineering Documents (phone: 1-877-413-5184, website: www.global.ihs.com).

Safe Practices for the Preparation of Containers and Piping for Welding and Cutting, American Welding Society Standard AWS F4.1, from Global Engineering Documents (phone: 1-877-413-5184, website: www.global.ihs.com).

National Electrical Code, NFPA Standard 70, from National Fire Protection Association, Quincy, MA 02269 (phone: 1-800-344-3555, website: www.nfpa.org and www.sparky.org).

Safe Handling of Compressed Gases in Cylinders, CGA Pamphlet P-1, from Compressed Gas Association, 4221 Walney Road, 5th Floor, Chantilly, VA 20151 (phone: 703-788-2700, website: www.cganet.com).

Safety in Welding, Cutting, and Allied Processes, CSA Standard W117.2, from Canadian Standards Association, Standards Sales, 5060 Spectrum Way, Suite 100, Ontario, Canada L4W 5N5 (phone: 800-463-6727, website: www.csa-international.org).

Battery Chargers, CSA Standard C22.2 NO 107.2-01, from Canadian Standards Association, Standards Sales, 5060 Spectrum Way, Suite 100, Ontario, Canada L4W 5N5 (phone: 800-463-6727, website: www.csa-international.org).

Safe Practice For Occupational And Educational Eye And Face Protection, ANSI Standard Z87.1, from American National Standards Institute,

25 West 43rd Street, New York, NY 10036 (phone: 212-642-4900, website: www.ansi.org).

Standard for Fire Prevention During Welding, Cutting, and Other Hot Work, NFPA Standard 51B, from National Fire Protection Association, Quincy, MA 02269 (phone: 1-800-344-3555, website: www.nfpa.org).

For Standards about hydraulic systems, contact the National Fluid Power Association, Publications Department, 3333 North Mayfair Road, Suite 211, Milwaukee, WI 53222-3219 (phone: (414) 778-3344, website: www.nfpa.com).

OSHA, Occupational Safety and Health Standards for General Industry, Title 29, Code of Federal Regulations (CFR), Part 1910, Subpart Q, and Part 1926, Subpart J, from U.S. Government Printing Office, Superintendent of Documents, P.O. Box 371954, Pittsburgh, PA 15250-7954 (phone: 1-866-512-1800) (there are 10 OSHA Regional Offices—phone for Region 5, Chicago, is 312-353-2220, website: www.osha.gov).

U.S. Consumer Product Safety Commission (CPSC), 4330 East West Highway, Bethesda, MD 20814 (phone: 301-504-7923, website: www.cpsc.gov).

Applications Manual for the Revised NIOSH Lifting Equation, The National Institute for Occupational Safety and Health (NIOSH), 1600 Clifton Rd, Atlanta, GA 30333 (phone: 1-800-232-4636, website: www.cdc.gov/NIOSH).

2-9. Informations relatives aux CEM

Le courant électrique qui traverse tout conducteur génère des champs électromagnétiques (CEM) à certains endroits. Le courant de soudage crée un CEM autour du circuit et du matériel de soudage. Les CEM peuvent créer des interférences avec certains implants médicaux comme des stimulateurs cardiaques. Des mesures de protection pour les porteurs d'implants médicaux doivent être prises: par exemple, des restrictions d'accès pour les passants ou une évaluation individuelle des risques pour les soudeurs. Tous les soudeurs doivent appliquer les procédures suivantes pour minimiser l'exposition aux CEM provenant du circuit de soudage:

1. Rassembler les câbles en les torsadant ou en les attachant avec du ruban adhésif ou avec une housse.
2. Ne pas se tenir au milieu des câbles de soudage. Disposer les câbles d'un côté et à distance de l'opérateur.
3. Ne pas courber et ne pas entourer les câbles autour de votre corps.



















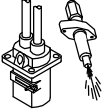
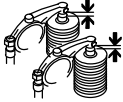





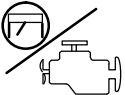



4. Maintenir la tête et le torse aussi loin que possible du matériel du circuit de soudage.
5. Connecter la pince sur la pièce aussi près que possible de la soudure.
6. Ne pas travailler à proximité d'une source de soudage, ni s'asseoir ou se pencher dessus.
7. Ne pas souder tout en portant la source de soudage ou le dévidoir.

En ce qui concerne les implants médicaux :

Les porteurs d'implants doivent d'abord consulter leur médecin avant de s'approcher des opérations de soudage à l'arc, de soudage par points, de gougeage, du coupage plasma ou de chauffage par induction. Si le médecin approuve, il est recommandé de suivre les procédures précédentes.

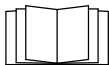
SECTION 3 – DEFINITIONS

3-1. Symbols And Definitions

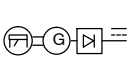
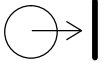
	Stop Engine		Fast (Run, Weld/Power)		Slow (Idle)		Start Engine
	Starting Aid		Battery (Engine)		Engine Oil Pressure		Engine Oil
	Check Injectors/Pump		Check Valve Clearance		Fuel		Protective Earth (Ground)
+	Positive	—	Negative		Certified/Trained Mechanic		Welding Arc
A	Amperes	V	Volts		Panel/Local		Remote
	Engine		Air Temperature Or Engine Temperature		Output		Alternating Current
	Stick (SMAW) Welding		Constant Current (CC)		MIG (GMAW) Welding		TIG (GTAW)
	Time	h	Hours	s	Seconds	1 	Single Phase
3 	Three Phase		Read Operator's Manual		Circuit Protector		Do Not Switch While Welding
	Electrode Connection		Work Connection		Engine-Driven, Three-Phase Alternator With Rectifier	Hz	Hertz
	Contactor On						

SECTION 4 – SPECIFICATIONS

4-1. Weld, Power, And Engine Specifications

Welding Mode	Weld Output Range	Rated Welding Output	Maximum Open-Circuit Voltage	Generator Power Rating	Engine	Fuel Capacity
CC/DC	20 – 600 A	500 A, 40 Volts DC, 100% Duty Cycle	95	Three-Phase Generator Single-Phase/Three-Phase, 12/20 kVA/kW, 50/48A, 120/240 VAC, 60 Hz In Addition To Standard 4 kVA/kW Generator Power	Kubota V3300-B Water-Cooled, Four Cylinder, 49.5 HP Diesel Engine	25 gal (95 L)
CV/DC	14 – 40 V	600 A, 44 Volts DC, 40% Duty Cycle	56			

4-2. Dimensions, Weights, And Operating Angles

Dimensions	
Height	50 in. (1270 mm) (to top of muffler)
Width	28-1/2 in. (724 mm) (mtg. brackets turned in)
	30-3/4 in. (781 mm) (mtg. brackets turned out)
Depth	69-1/2 in. (1765 mm)
A	69-1/2 in. (1765 mm)
B*	55-7/8 in. (1419 mm)
C*	46-3/8 in. (1178)
D*	9-1/2 in. (241 mm)
E	27-1/2 in. (699 mm)
F	1 in. (25 mm)
G	29-13/16 in. (757 mm)
H	9/16 in. (14 mm) Dia. 4 Holes
* With mounting brackets in center position. Dimensions vary with location of mounting brackets.	
Weight	
No fuel: 1808 lb (820 kg)	
Lifting Eye Weight Rating: 2380 lb (1079 kg) Maximum Meets IEC Standard 60-974-1	

802 161-A

804 582-A

⚠ Do not exceed tilt angles or engine could be damaged or unit could tip.

⚠ Do not move or operate unit where it could tip.

4-3. Volt-Ampere Curves

A. Stick Mode

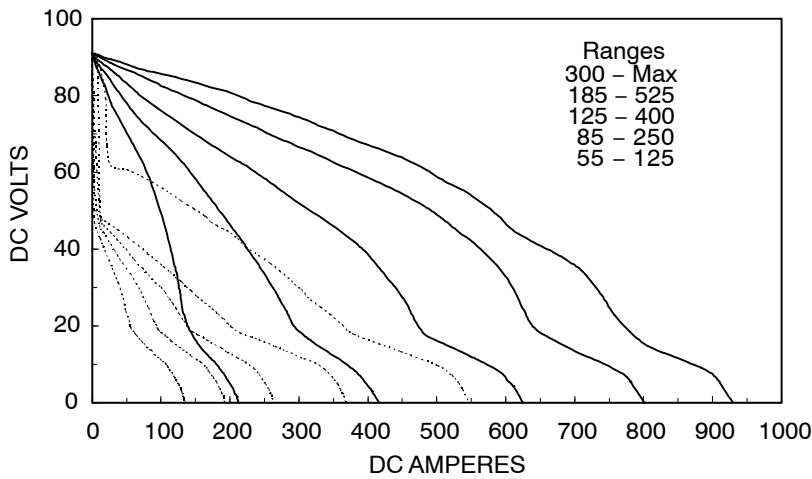

The volt-ampere curves show the minimum and maximum voltage and amperage output capabilities of the welding generator. Curves of all other settings fall between the curves shown.

B. MIG Mode

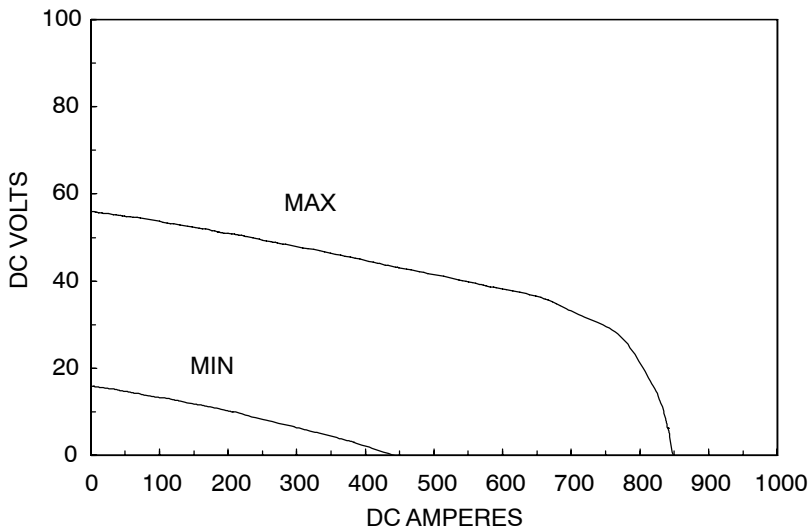

C. TIG Mode

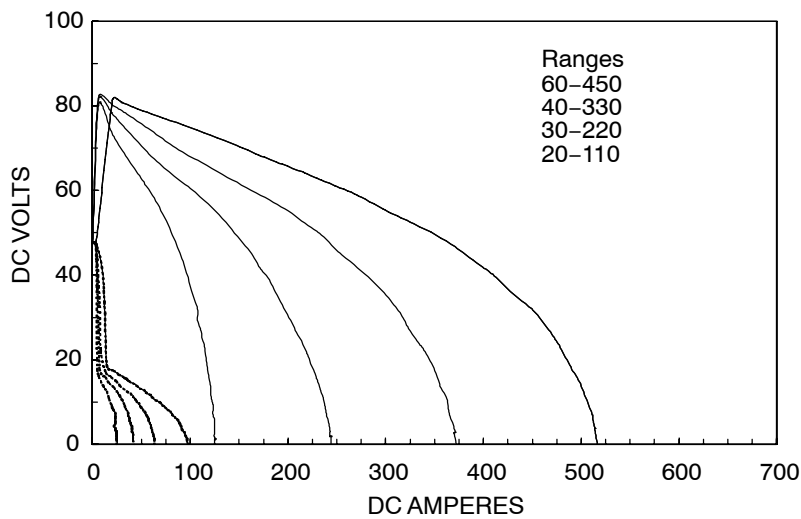

4-4. Fuel Consumption

The curve shows typical fuel use under weld or power loads.

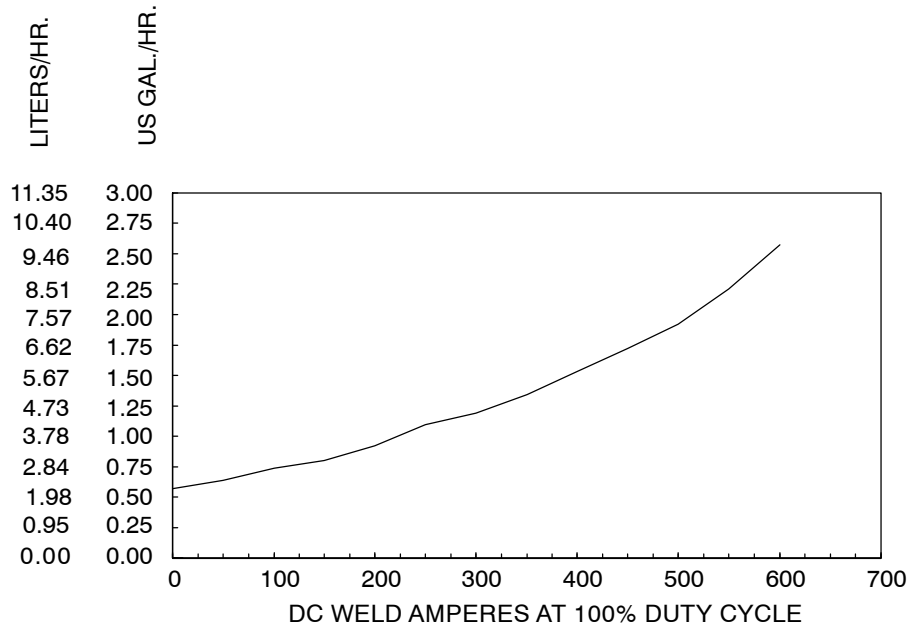

208 137

4-5. Duty Cycle And Overheating

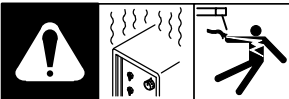

100% Duty Cycle At 500 Amperes



Continuous Welding

Duty Cycle is percentage of 10 minutes that unit can weld at rated load without overheating.

NOTICE - Exceeding duty cycle can damage unit and void warranty.

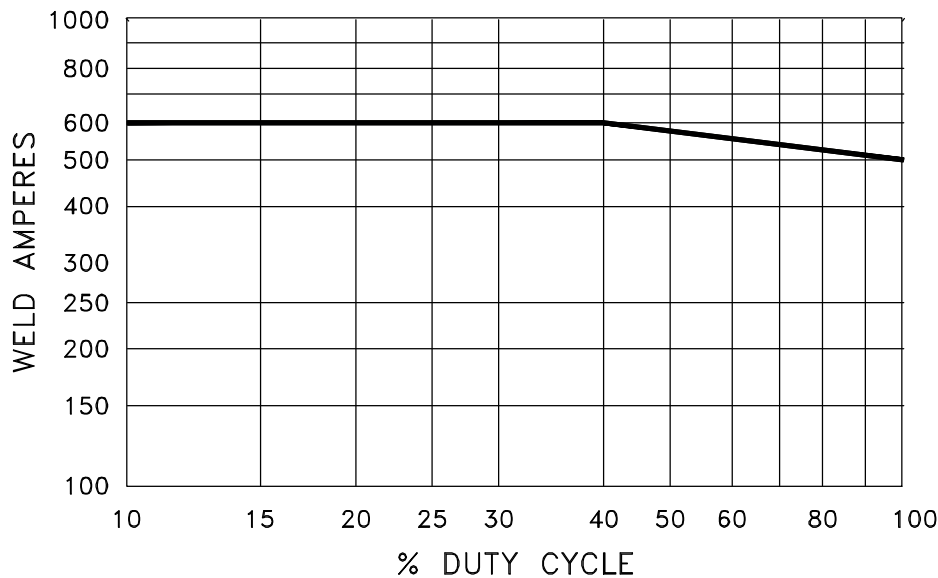

202 356

4-6. Generator Power Curve

A. 12 kVA/kW Single-Phase AC Output (No Weld Load)

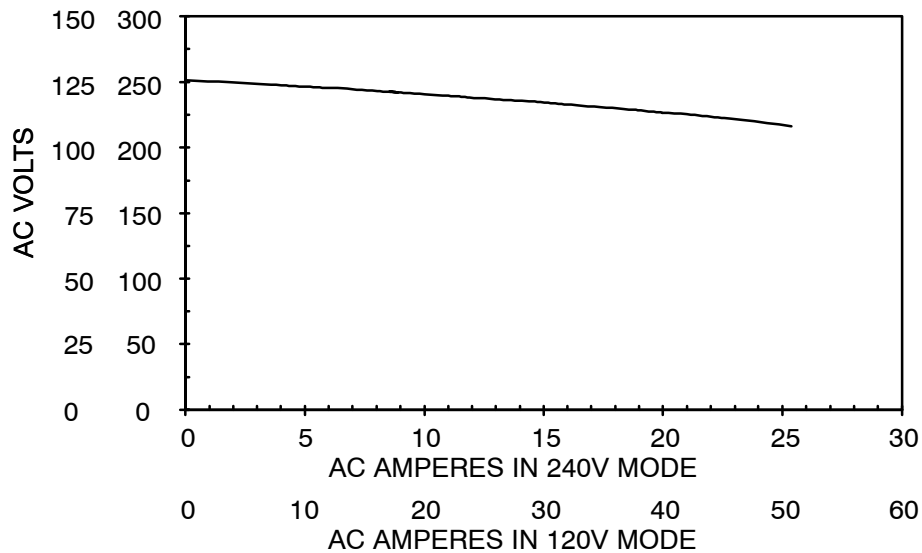

The Standard AC power curve shows the generator power in amperes available at the 120 and 240 volt receptacles.

The Three-Phase AC power curve shows the generator output available in amperes at the three-phase 240 volt terminals.

B. 20 kVA/kW Three-Phase AC Output (No Weld Load)

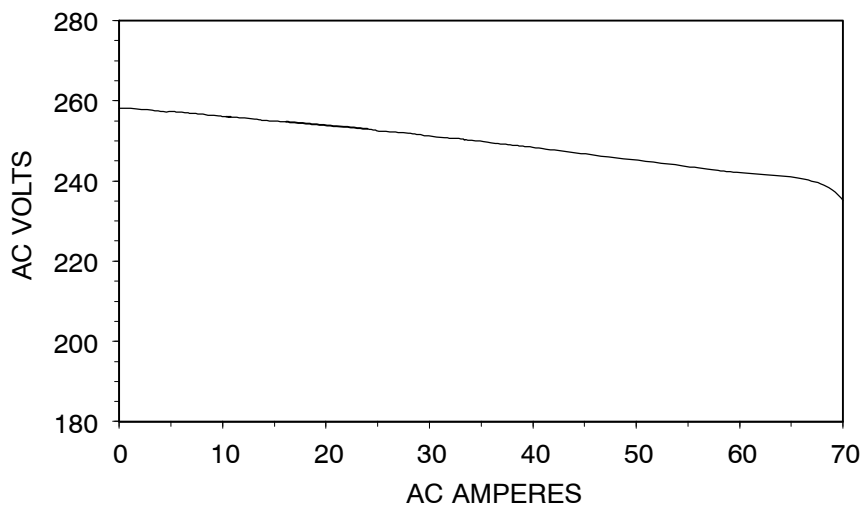

SECTION 5 – INSTALLATION

5-1. Serial Number And Rating Label Location

The serial number and rating information for this product is located on the front. Use rating label to determine input power requirements and/or rated output. For future reference, write serial number in space provided on back cover of this manual.

5-2. Installing Welding Generator



- Do not move or operate unit where it could tip.
- Always securely fasten welding generator onto transport vehicle or trailer and comply with all DOT and other applicable codes.

Movement

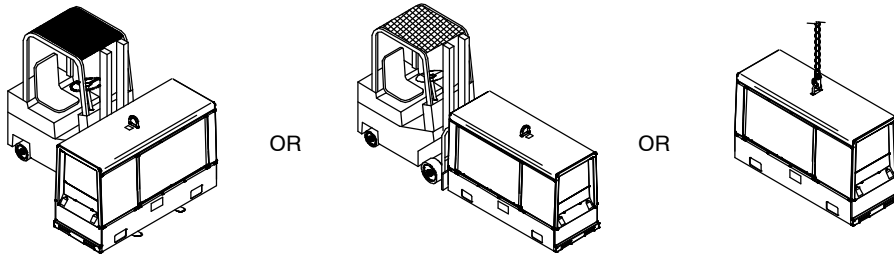

- NOTICE** – Do not install unit where air flow is restricted or engine may overheat.
- See Section 4-2 for lifting eye rating.
 - See Section 5-3 for mounting information.

Location/Airflow Clearance

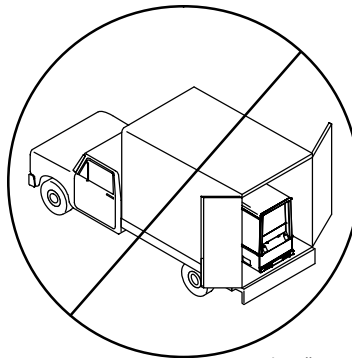
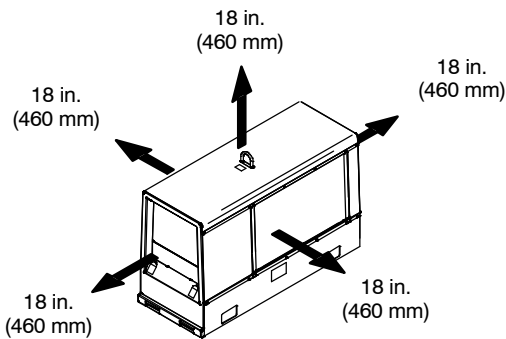
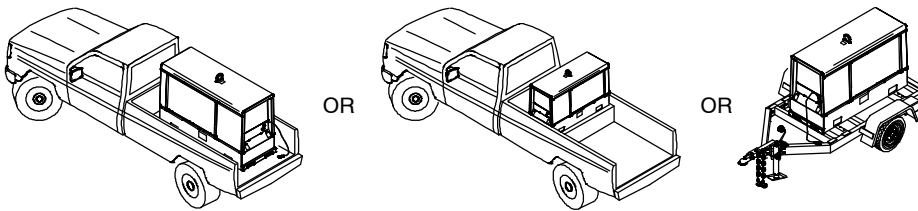

install3 2008-01 – Ref. 800 652 / Ref. 800 477-A / 803 274 / 804 712

5-3. Mounting Welding Generator



Supporting The Unit

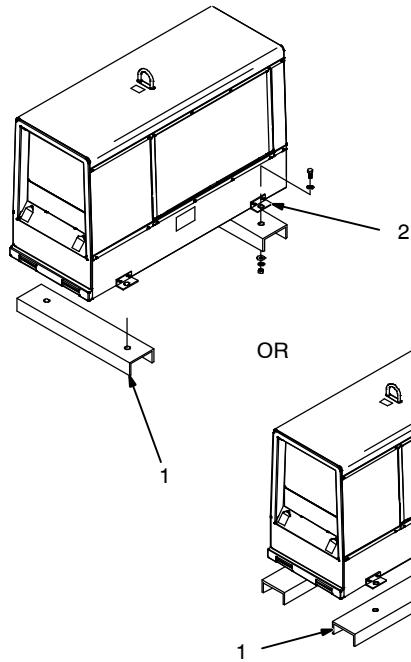
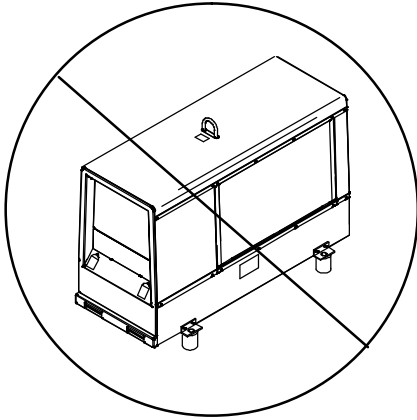

⚠ Do not weld on base. Welding on base can cause fuel tank fire or explosion. Weld only on the four mounting brackets or bolt unit down.

NOTICE – Do not mount unit by supporting the base only at the four mounting brackets. Use cross-supports to adequately support unit and prevent damage to base.

Mounting Surface:

1 Cross-Supports
2 Mounting Brackets (Supplied)
Mount unit on flat surface or use cross-supports to support base. Secure unit with mounting brackets.

3 1/2 in. Bolt And Washer (Minimum – Not Supplied)
4 3/8-16 x 1 in. Screws (Supplied)

To Bolt Unit In Place:

Remove hardware securing the four mounting brackets to the base. Reverse brackets and reattach to base with original hardware.

Mount unit to truck or trailer with 1/2 in. (12 mm) or larger hardware (not supplied).

To Weld Unit In Place:

Weld unit to truck or trailer only at the four mounting brackets.

Using Mounting Brackets

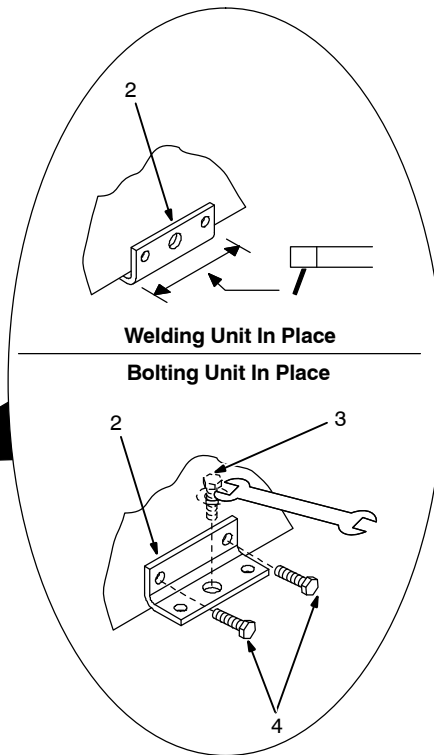
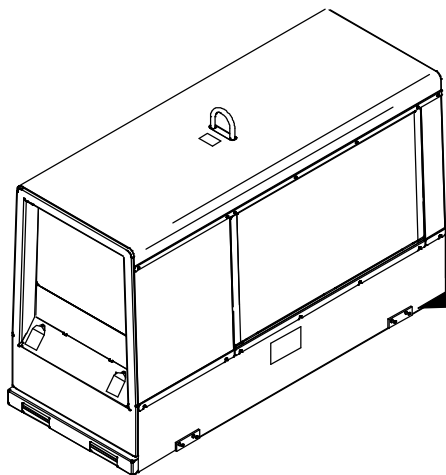

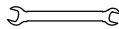
Tools Needed:
 9/16 in.

install3 2008--01 803 274 / 200 864-A / 803 231

5-4. Grounding Generator To Truck Or Trailer Frame

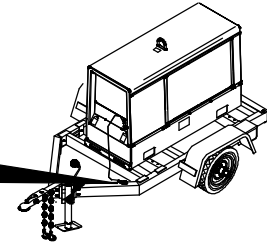
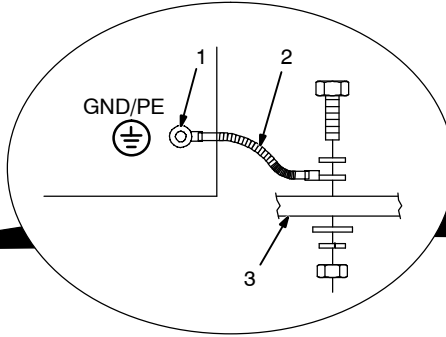
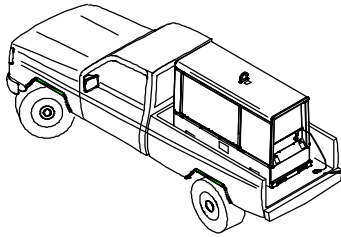

rot_grnd2 2011-04 - 800 652-D

- ⚠ Always ground generator frame to vehicle frame to prevent electric shock and static electricity hazards.
- ⚠ Also see AWS Safety & Health Fact Sheet No. 29, Grounding of Portable And Vehicle Mounted Welding Generators.
- ⚠ Bed liners, shipping skids, and some running gear insulate the

welding generator from the vehicle frame. Always connect a ground wire from the generator equipment grounding terminal to bare metal on the vehicle frame as shown.

- ⚠ Use GFCI protection when operating auxiliary equipment. If unit does not have GFCI receptacles, use GFCI-protected extension cord.

- 1 Equipment Grounding Terminal (On Front Panel)
- 2 Grounding Cable (Not Supplied)
- 3 Metal Vehicle Frame

Connect cable from equipment ground terminal to metal vehicle frame. Use #8 AWG or larger insulated copper wire.

 Electrically bond generator frame to vehicle frame by metal-to-metal contact.

5-5. Using Lifting Eye

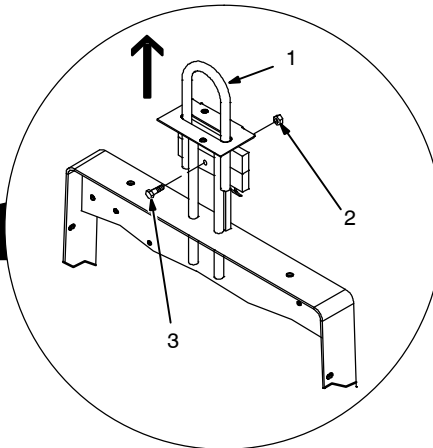
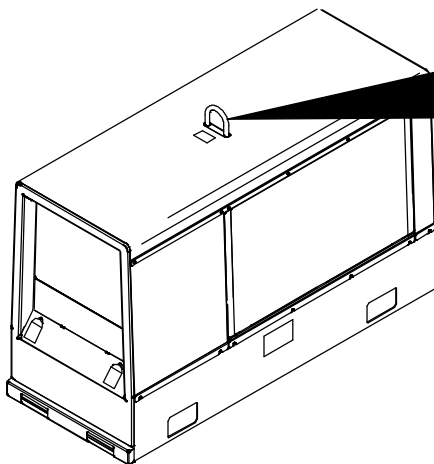
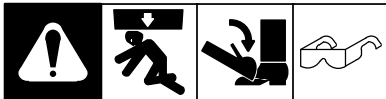

- 1 Lifting Eye
- 2 Nut
- 3 Carriage Bolt

Raise lifting eye until it snaps in place. Lower lifting eye when not needed.

To lock the lifting eye in the upright position, insert a 3/8-16 x 1-1/2 in. carriage bolt through slot in bracket and secure with nut (bolt and nut not supplied).

Tools Needed:

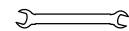

Lift1 2008-01 804 712

5-6. Installing Exhaust Pipe



⚠ Stop engine and let cool.

👉 Point exhaust pipe in desired direction but always away from front panel and direction of travel.

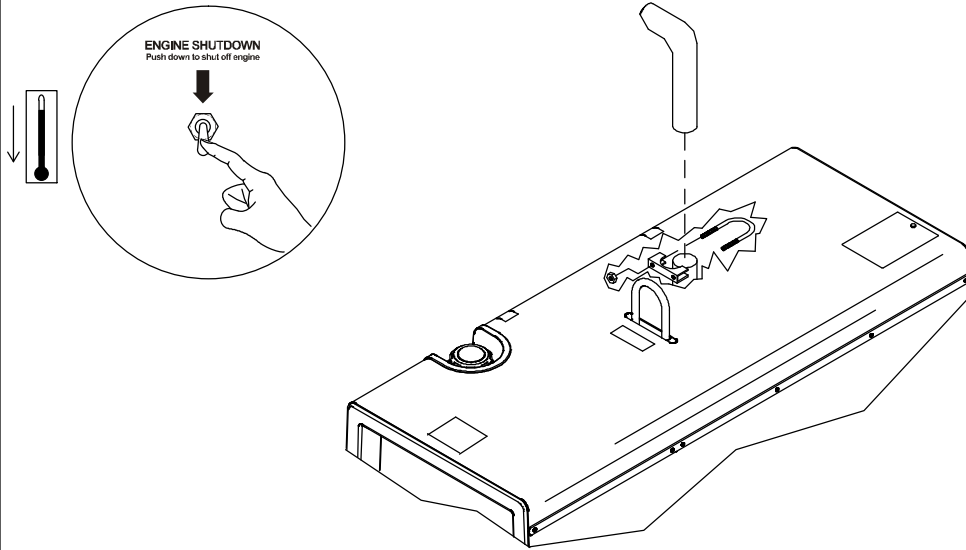

Tools Needed:

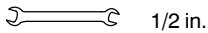

Exhaust1 2008-01 Ref. 803 604 / Ref. 202 705

5-7. Activating The Dry Charge Battery (If Applicable)

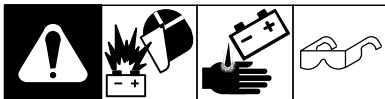

⚠ Always wear a face shield, rubber gloves and protective clothing when working on a battery.

Remove battery from unit.

- 1 Vent Caps
- 2 Sulfuric Acid Electrolyte (1.265 Specific Gravity)
- 3 Well

Fill each cell with electrolyte to **bottom** of well (maximum).

⚠ Do not overfill battery cells.

Wait ten minutes and check electrolyte level. If necessary, add electrolyte to raise to proper level. Reinstall vent caps.

- 4 Battery Charger

⚠ Read and follow all instructions supplied with battery charger.

- 5 5 Amperes For 30 Minutes Charge Time
- 6 30 Amperes For 12 Minutes Charge Time

Charge battery. Disconnect charging cables and install battery.

👉 When electrolyte is low, add only distilled water to cells to maintain proper level.

Tools Needed:

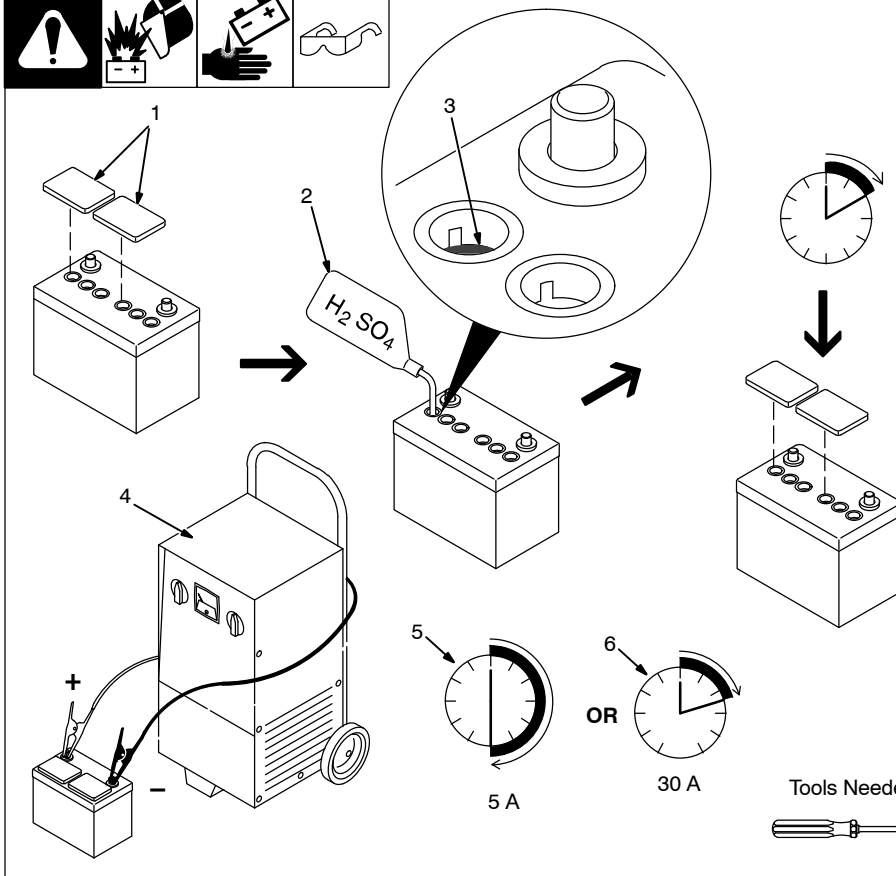

drybatt 12008-01 - S-0886

5-8. Connecting The Battery

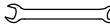
Tools Needed:
 1/2 in.

Connect negative (-) battery cable last.

Reinstall cover after connecting battery.

Conn_batt1 2008-02 802 168-E / Ref. 202 705 / 802 313 / S-0756-C

Notes

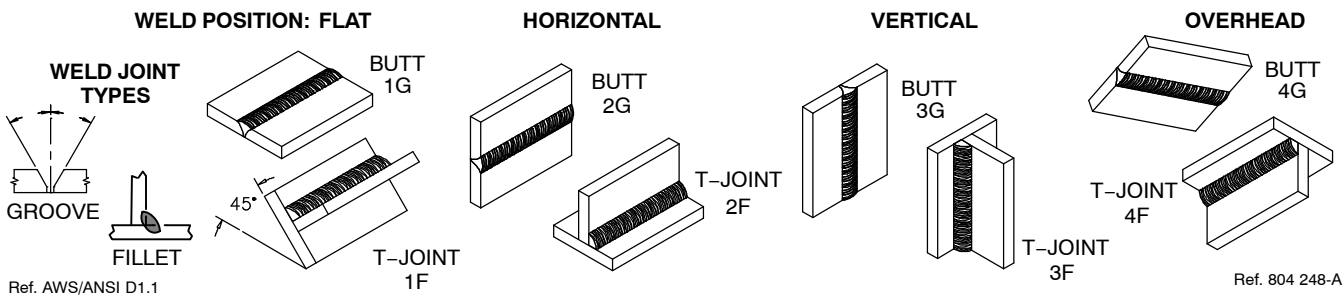

5-9. Engine Prestart Checks

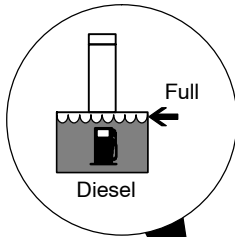

NOTICE – Follow run-in procedure in engine manual. If unburned fuel and oil collect in exhaust pipe during run-in, see Section 10.

Remove air bleed screw when filling radiator. See Section 8-8.

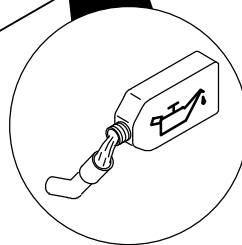
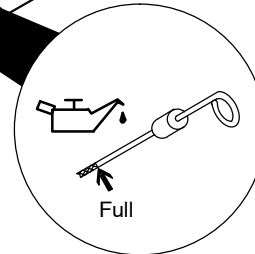
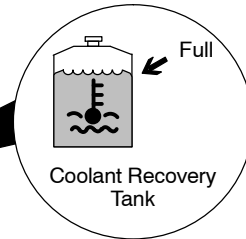
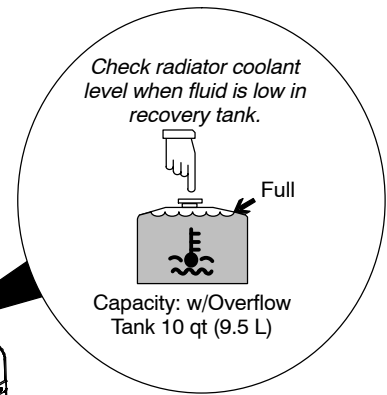

804 583-A

☞ Check all engine fluids daily.

Engine must be cold and on a level surface. The automatic shutdown system stops engine if oil pressure is too low or coolant temperature is too high.

☞ This unit has a low oil pressure shutdown switch. However, some conditions may cause engine damage before the engine shuts down. Check oil level often and do not use the oil pressure shutdown system to monitor oil level.

NOTICE – Follow run-in procedure in engine manual. If unburned fuel and oil collect in exhaust pipe during run-in, see Section 10.

Fuel

NOTICE – Do not use gasoline. Gasoline will damage engine.

NOTICE – Do not use ether to start engine.

Add fresh diesel fuel before starting to prevent air from entering the fuel system (see

engine maintenance label for fuel specifications). Leave filler neck empty to allow room for expansion.

Engine stops if fuel level is low.

Oil

After fueling, check oil with unit on level surface. If oil is not up to full mark on dipstick, add oil (see maintenance label).

NOTICE – Engine may use oil and wets-tacking may occur during run-in. Check oil several times daily during run-in.

Coolant

Check coolant level in radiator before starting unit the first time. Add coolant if below bottom of filler neck (see Section 8-8 for radiator filling instructions).

Check coolant level in recovery tank daily. If coolant is below Cold Full level, add coolant until level in tank is between Cold Full and Hot Full levels. If recovery tank coolant level was low, check coolant level in radiator (see Section 8-8).

Engine coolant is a mixture of water and ethylene glycol base antifreeze. A solution of 50% antifreeze and 50% water must be used in this engine. Do not use 100% antifreeze or severe damage will occur.

Keep radiator and air intake clean.

NOTICE – Incorrect engine temperature can damage engine. Do not run engine without a properly working thermostat and radiator cap.

☞ To improve cold weather starting:

Use Engine Start/Preheat switch to operate glow plug (see Section 6-1).

Keep battery in good condition. Store battery in warm area.

Use fuel formulated for cold weather (diesel fuel can gel in cold weather). Contact local fuel supplier for fuel information.

Use correct grade oil for cold weather (see Section 8-1).

5-10. Weld Output Terminals

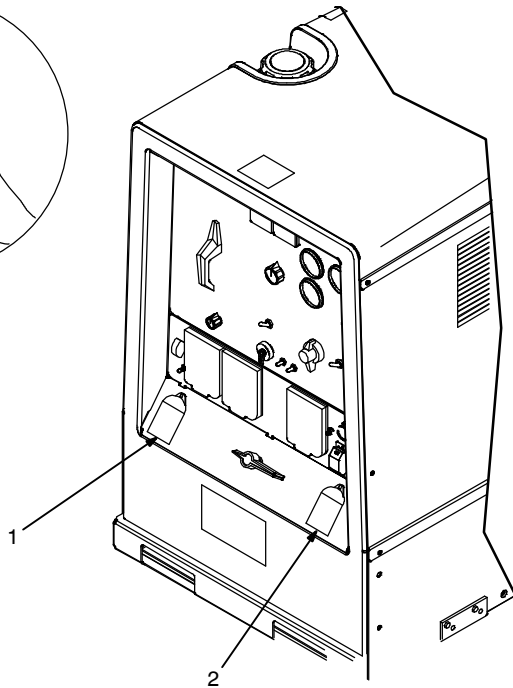
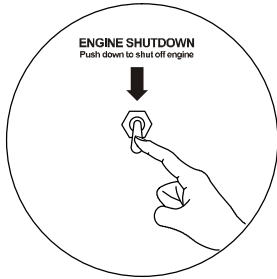

- 1 Positive (+) Weld Output Terminal
- 2 Negative (-) Weld Output Terminal

Stick and TIG Welding

For Stick and TIG welding Direct Current Electrode Positive (DCEP), connect electrode holder cable to Positive (+) terminal on left and work cable to Negative (-) terminal on right.

For Direct Current Electrode Negative (DCEN), reverse cable connections.

If equipped with optional Polarity switch or optional Polarity/AC switch, connect electrode holder cable to Electrode (+) terminal on left and work cable to Work (-) terminal on right.

MIG and FCAW Welding

For MIG and FCAW welding Direct Current Electrode Positive (DCEP) on CC/CV models, connect wire feeder cable to Positive (+) terminal on left and work cable to Negative (-) terminal on right. Use Process/Contactor switch to select type of weld output (see Section 6-3).

For Direct Current Electrode Negative (DCEN), reverse cable connections.

If equipped with optional Polarity switch or optional Polarity/AC switch, connect wire feeder cable to Electrode (+) terminal on left and work cable to Work (-) terminal on right.

804 582 / 242 336

5-11. Connecting Weld Output Cables

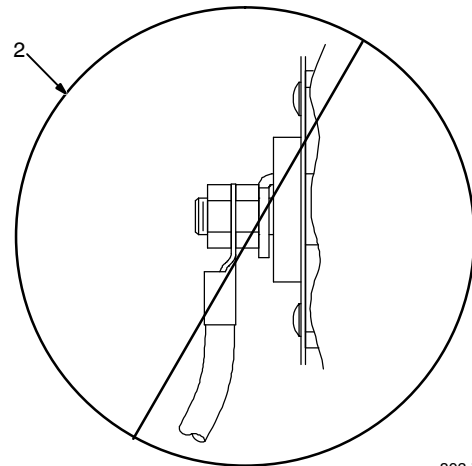
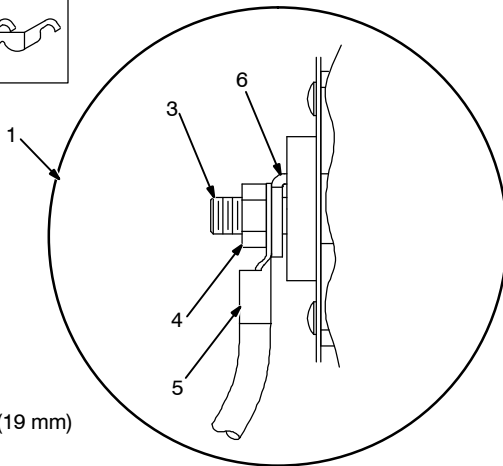

Tools Needed:

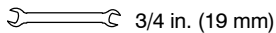

803 778-B

⚠ Turn off power before connecting to weld output terminals.

⚠ Failure to properly connect weld cables may cause excessive heat and start a fire, or damage your machine.

🚫 Do not place anything between weld

cable terminal and copper bar. Make sure that the surfaces of the weld cable terminal and copper bar are clean.

- 1 Correct Weld Cable Connection
- 2 Incorrect weld Cable Connection
- 3 Weld Output Terminal
- 4 Supplied Weld Output Terminal Nut

5 Weld Cable Terminal

6 Copper Bar

Remove supplied nut from weld output terminal. Slide weld cable terminal onto weld output terminal and secure with nut so that weld cable terminal is tight against copper bar.

5-12. Selecting Weld Cable Sizes*

NOTICE – The Total Cable Length in Weld Circuit (see table below) is the combined length of both weld cables. For example, if the power source is 100 ft (30 m) from the workpiece, the total cable length in the weld circuit is 200 ft (2 cables x 100 ft). Use the 200 ft (60 m) column to determine cable size.

 Weld Output Terminals	Weld Cable Size** and Total Cable (Copper) Length in Weld Circuit Not Exceeding***									
	Welding Amperes			100 ft (30 m) or Less	150 ft (45 m)	200 ft (60 m)	250 ft (70 m)	300 ft (90 m)	350 ft (105 m)	400 ft (120 m)
		10 – 60% Duty Cycle AWG (mm²)	60 – 100% Duty Cycle AWG (mm²)	10 – 100% Duty Cycle AWG (mm²)						
	100	4 (20)	4 (20)	4 (20)	3 (30)	2 (35)	1 (50)	1/0 (60)	1/0 (60)	
	150	3 (30)	3 (30)	2 (35)	1 (50)	1/0 (60)	2/0 (70)	3/0 (95)	3/0 (95)	
	200	3 (30)	2 (35)	1 (50)	1/0 (60)	2/0 (70)	3/0 (95)	4/0 (120)	4/0 (120)	
	250	2 (35)	1 (50)	1/0 (60)	2/0 (70)	3/0 (95)	4/0 (120)	2x2/0 (2x70)	2x2/0 (2x70)	
	300	1 (50)	1/0 (60)	2/0 (70)	3/0 (95)	4/0 (120)	2x2/0 (2x70)	2x3/0 (2x95)	2x3/0 (2x95)	
	350	1/0 (60)	2/0 (70)	3/0 (95)	4/0 (120)	2x2/0 (2x70)	2x3/0 (2x95)	2x3/0 (2x95)	2x4/0 (2x120)	
	400	1/0 (60)	2/0 (70)	3/0 (95)	4/0 (120)	2x2/0 (2x70)	2x3/0 (2x95)	2x4/0 (2x120)	2x4/0 (2x120)	
	500	2/0 (70)	3/0 (95)	4/0 (120)	2x2/0 (2x70)	2x3/0 (2x95)	2x4/0 (2x120)	3x3/0 (3x95)	3x3/0 (3x95)	
	600	3/0 (85)	4/0 (120)	2x2/0 (2x70)	2x3/0 (2x95)	2x4/0 (2x120)	3x3/0 (3x95)	3x4/0 (3x120)	3x4/0 (3x120)	
	700	4/0 (110)	2x2/0 (2x70)	2x3/0 (2x95)	2x4/0 (2x120)	3x3/0 (3x95)	3x4/0 (3x120)	3x4/0 (3x120)	4x4/0 (4x120)	



* This chart is a general guideline and may not suit all applications. If cable overheats, use next size larger cable.

**Weld cable size (AWG) is based on either a 4 volts or less drop or a current density of at least 300 circular mils per ampere.
() = mm² for metric use

***For distances longer than those shown in this guide, call a factory applications rep. at 920-735-4505 (Miller) or 1-800-332-3281 (Hobart).

Ref. S-0007-J 2011-07

5-13. Connecting To Remote 14 Receptacle RC14

 REMOTE 14	Socket*	Socket Information
24 VOLTS AC  OUTPUT (CONTACTOR)	A	24 volts AC. Protected by supplementary protector CB5.
	B	Contact closure to A completes 24 volt AC contactor control circuit.
REMOTE OUTPUT CONTROL	C	Output to remote control: +10 volts DC in MIG or Stick mode; 0 to +10 volts DC in TIG mode.
	D	Remote control circuit common.
	E	DC input command signal: 0 to +10 volts from min. to max. of remote control with Voltage/ Amperage Adjust control at max.
115 VOLTS AC  OUTPUT (CONTACTOR)	I	115 volts, 10 amperes, 60 Hz AC. Protected by supplementary protector CB13.
	J	Contact closure to I completes 115 volt AC contactor control circuit.
GND	K	Chassis common.
NEUTRAL	G	Circuit common for 24 and 115 volt AC circuit.

*The remaining sockets are not used.

SECTION 6 – OPERATING WELDING GENERATOR

6-1. Front Panel Controls (See Section 6-2)

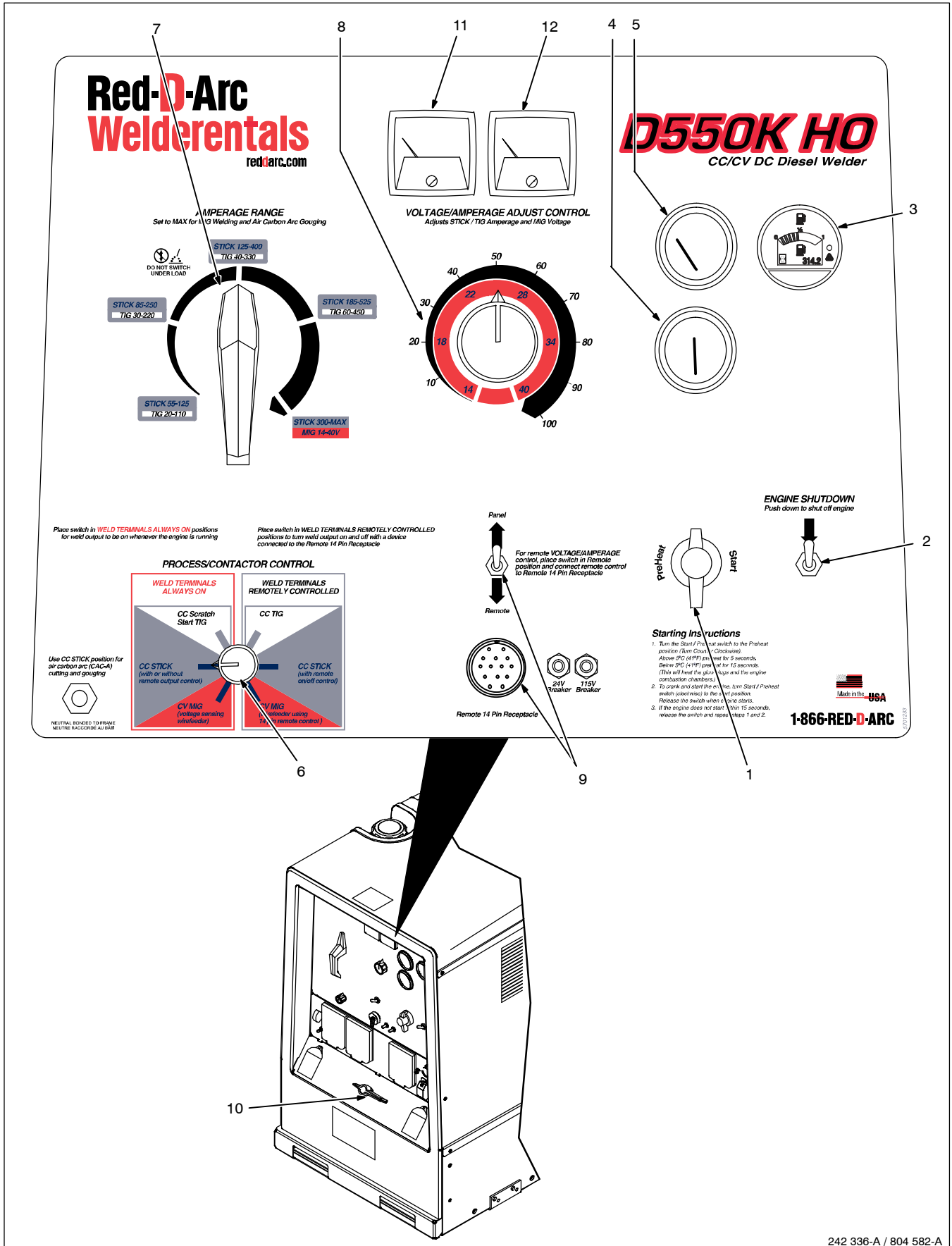

6-2. Description Of Front Panel Controls (See Section 6-1)

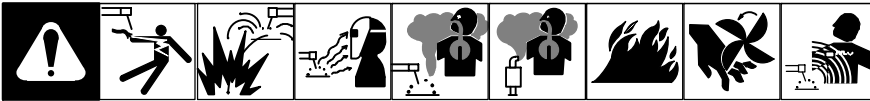

Engine Starting Controls

1 Start/Preheat Switch

Use switch to start engine and operate glow plug for cold weather starting.

Engine runs at weld/power speed continuously.

Turn switch to Preheat position to operate the glow plug and heat the combustion chambers before cranking engine (see starting instructions following).

2 Engine Shutdown Switch

Push switch down to stop engine.

To Start:

NOTICE – Do not use ether to start engine.

If engine does not start, let engine come to a complete stop before attempting restart.

Above 41° F (5° C): turn Start/Preheat switch to Preheat position for 5 seconds and then turn switch to Start position. Release Start/Preheat switch when engine starts.

Below 41° F (5° C):

Turn Start/Preheat switch to Preheat position for 15 seconds and then turn switch to Start. Release Start/Preheat switch when engine starts.

To Stop:

Push Engine Shutdown switch down to stop engine.

Engine Gauges

To read gauges with engine off, turn Start/Preheat switch to Preheat position.

3 Engine Fuel/Hour Gauge

Use meter to monitor engine running time for

scheduling maintenance.

Use gauge to check fuel level. Engine stops if fuel level is low.

To check fuel level when engine is not running place Engine Control switch in Preheat position then default back to neutral position.

See Section 6-5 for complete fuel/hour gauge information.

4 Battery Ammeter

Use gauge to check amperage output to the battery. The gauge reads near 0 (zero) when the engine is running. If gauge is at a negative number, the battery is discharging.

NOTICE – Stop engine, and do not run engine until problem is fixed.

5 Engine Temperature Gauge

Normal temperature is 170 - 205° F (77 - 96° C). Engine stops if temperature exceeds 221° F (105° C).

Weld Controls

6 Process/Contactor Control Switch

See Section 6-3 for Process/Contactor Control switch information.

7 Amperage Range Switch

NOTICE – Do not switch under load.

Use switch to select weld amperage range.

Use the lowest four ranges for Stick and TIG welding. Read the upper set of numbers at each range for Stick welding and the lower set at each range for TIG welding.

Use the highest range for MIG welding and for cutting and gouging (CAC-A).

For most welding applications, use lowest amperage range possible to help prevent arc outages.

8 Voltage/Amperage Adjust Control

With Process/Contactor Control switch in any Stick or TIG setting, use control to adjust amperage within range selected by Amperage Range switch. With Process/Contactor Control switch in any MIG position, use control to adjust voltage. With Voltage/Amperage Adjust Control switch (item 9) in Remote position, control limits the remote amperage in TIG mode, but has no effect in Stick and MIG modes.

Weld output would be about 263 A DC with controls set as shown (50% of 125 to 400 A).

The numbers around the control are for reference only and do not represent an actual percentage value.

9 Voltage/Amperage Adjust Control Switch And Remote 14 Receptacle

Use switch to select front panel or remote voltage/amperage control. For remote control, place switch in Remote position and connect remote control to Remote 14 receptacle RC14 (see Sections 5-13 and 6-4).

10 Polarity/AC Selector Switch (Optional)

NOTICE – Do not switch under load.

Use switch to change weld output. Select either DC Electrode Positive (DCEP) or DC Electrode Negative (DCEN).

Weld Meters

11 DC Voltmeter (Optional)

Voltmeter displays voltage at the weld output terminals, but not necessarily the welding arc due to resistance of cable and connections.

12 DC Ammeter (Optional)

Ammeter displays amperage output of the unit.

6-3. Process/Contactor Control Switch

Place switch in **WELD TERMINALS ALWAYS ON** positions for weld output to be on whenever the engine is running

Place switch in **WELD TERMINALS REMOTELY CONTROLLED** positions to turn weld output on and off with a device connected to the Remote 14 Pin Receptacle

PROCESS/CONTACTOR CONTROL

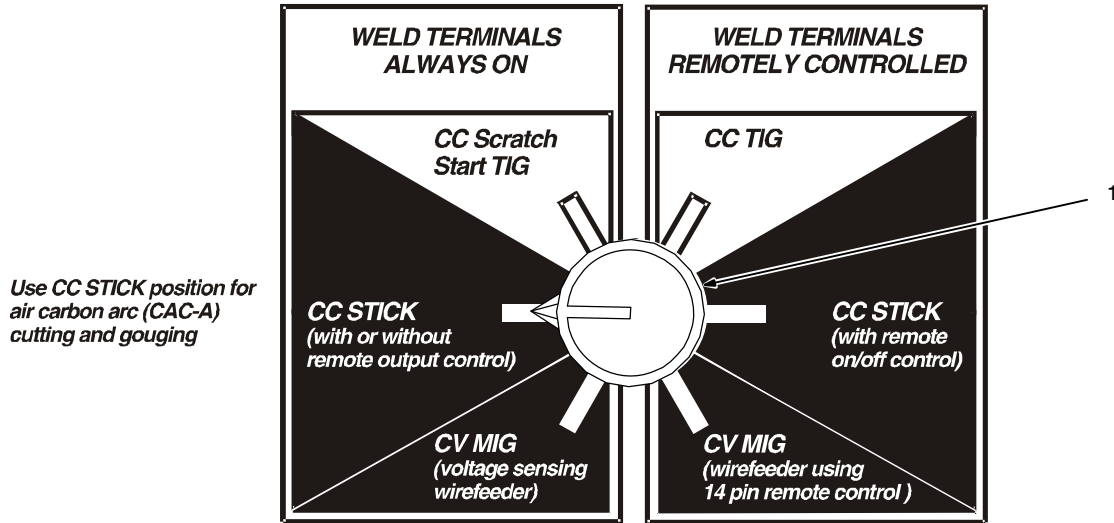

Use **CC STICK** position for air carbon arc (CAC-A) cutting and gouging

242 336-A

1 Process/Contactor Control Switch (See Section 6-1 For Location)

Section 6-4).

Use Weld Terminals Always On – CC Stick position for air carbon arc (CAC-A) cutting and gouging.

⚠ Weld output terminals are energized when Process/Contactor Control switch is in a Weld Terminals Always On position and the engine is running.

Place switch in Weld Terminals Remotely Controlled positions to turn weld output on and off with a device connected to the remote 14 receptacle.

When switch is in a Weld Terminals Always On – CC Stick position, the arc drive (dig) circuit provides additional amperage during low voltage (short arc length conditions) to prevent “sticking” electrodes.

Use switch to select weld process and weld output on/off control (see table below and

Place switch in Weld Terminals Always On positions for weld output to be on whenever the engine is running.

The arc drive (dig) circuit is disabled when switch is in MIG, TIG, and CC stick (With Remote On/Off Control) positions.

Process/Contactor Control Switch Settings

Switch Setting	Process	Output On/Off Control
Weld Terminals Remotely Controlled – CC TIG	GTAW With HF Unit, Pulsing Device, Or Remote Control	At Remote 14 Receptacle
Weld Terminals Remotely Controlled – CC Stick	Stick (SMAW) With Remote On/Off	At Remote 14 Receptacle
Weld Terminals Remotely Controlled – CV MIG	MIG (GMAW)	At Remote 14 Receptacle
Weld Terminals Always On – CV MIG	MIG (GMAW)	Electrode Hot
Weld Terminals Always On – CC Stick	Stick (SMAW), Air Carbon Arc (CAC-A) Cutting And Gouging	Electrode Hot
Weld Terminals Always On – CC Scratch Start TIG	Scratch Start TIG (GTAW)	Electrode Hot

6-4. Remote Voltage/Amperage Control



1 Remote 14 Receptacle RC14
Connect optional remote control to RC14 (see Section 5-13).

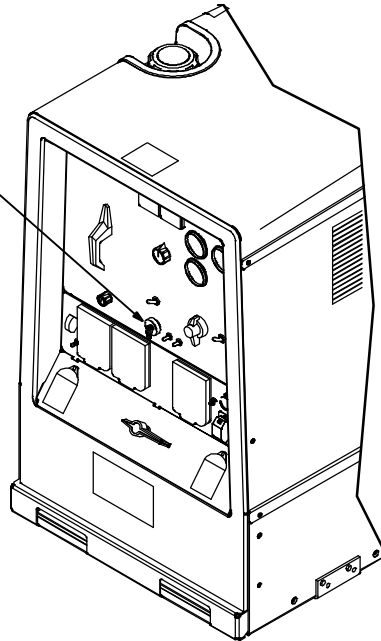

Example: Combination Remote Amperage Control (Stick) With Remote On/Off Control

In Example:
Process = Stick (Using Remote On/Off)
Range = 125 to 400 A DC
Min = 125 A DC
Max = 400 A DC

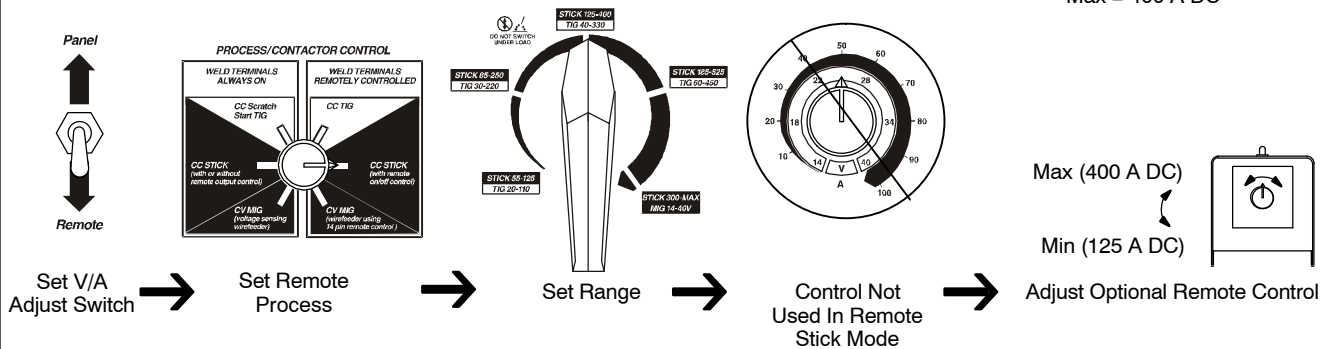



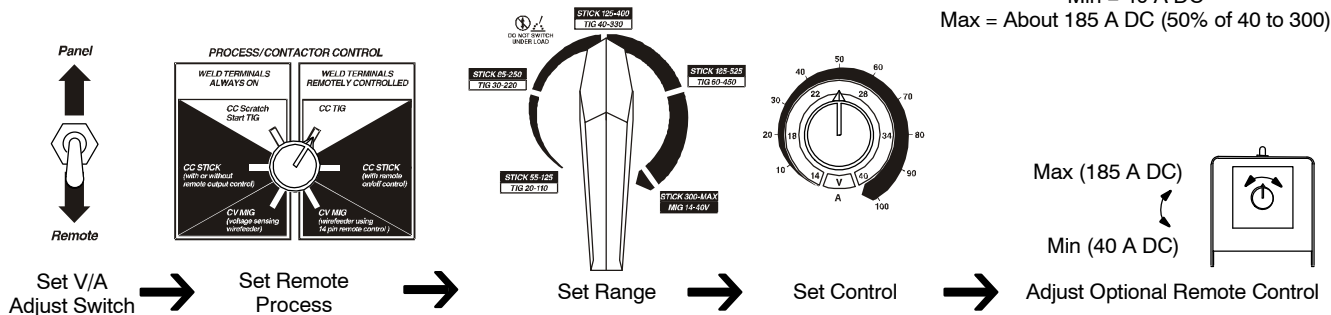

Example: Combination Remote Amperage Control (TIG) With Remote On/Off Control

In Example:
Process = TIG (Using Remote On/Off)
Range = 40 to 330 A DC
Percentage Of Range = 50%
Min = 40 A DC
Max = About 185 A DC (50% of 40 to 300)

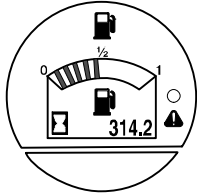
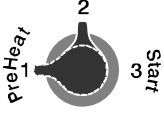
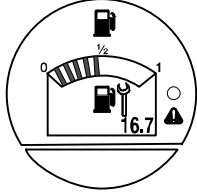
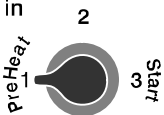
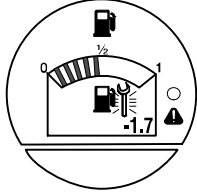
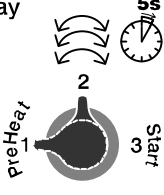
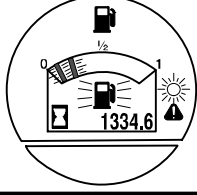
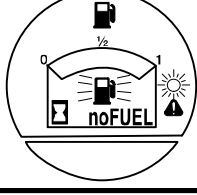
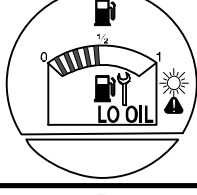

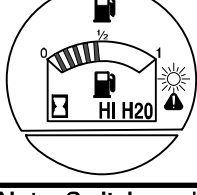
6-5. Fuel/Hour Gauge Descriptions

FUEL/HOUR GAUGE DESCRIPTIONS	
	<p>ENGINE HOURS: Gauge will display engine hours while engine is running. To display engine hours while the engine is off, place Engine Control switch in position "1" then default back to position "2".</p> 
	<p>OIL CHANGE INTERVAL: Gauge will display hours remaining before oil change is due with Engine Control switch held in position "1" (with engine off).</p> 
	<p>OIL CHANGE DUE: Gauge will display blinking wrench when oil change is due (0 to -99 hours).</p> <p>To Reset: Toggle Engine Control switch between position "1" and "2" three times within 5 seconds (engine off).</p> 
	<p>LOW FUEL PREWARNING: Fault indicator flashes when fuel level reaches 2 bars. Flashing rate increases as fuel level drops.</p> <p>LOW FUEL: Fuel level low when fuel icon and last bar in fuel gauge blink.</p> <p>To Reset: Refuel.</p>
	<p>NO FUEL: Engine shuts down before fuel runs out. Display shows "noFUEL", and fuel icon and fault indicator flash.</p> <p>To Reset: Refuel.</p>
	<p>LOW OIL PRESSURE: Engine shuts down when oil pressure is low. Display shows "LO OIL", fault indicator flashes and wrench is displayed.</p> <p>To Reset: Push Down on Engine Shutdown switch.</p> 
	<p>HIGH COOLANT TEMP: Engine shuts down when coolant temperature is high. Display shows "HI H2O" and fault indicator flashes.</p> <p>To Reset: Push Down on Engine Shutdown switch.</p> 
<p>Note: Switch positions are numbered to illustrate that there are three switch positions. Actual graphics on front panel will vary. 237 278-B</p>	

SECTION 7 – OPERATING AUXILIARY EQUIPMENT

7-1. 120 Volt And 240 Volt Receptacles

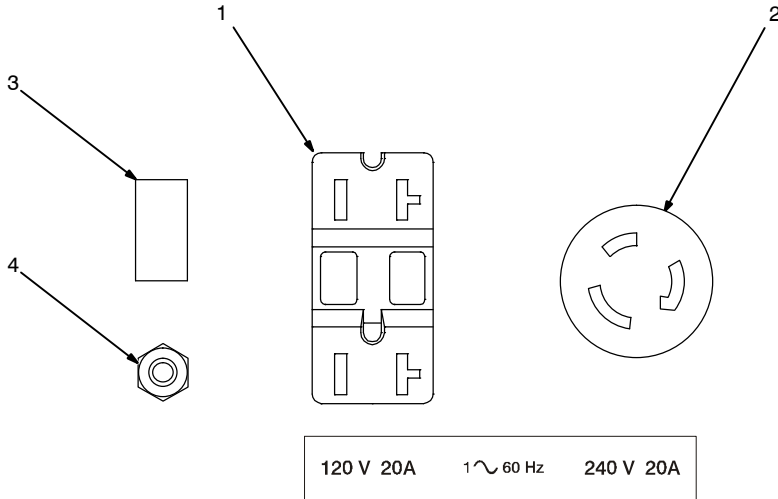

☞ Generator power is not affected by weld output.

- 1 120 V 20 A AC GFCI Receptacle GFCI1
- 2 240 V 30 A AC Twistlock Receptacle RC1

Receptacles supply 60 Hz single-phase power at weld/power speed.

If a ground fault is detected, GFCI Reset button pops out and receptacle does not work. Check for faulty tools plugged in receptacle. Press button to reset GFCI1.

☞ At least once a month, run engine at weld/power speed and press test button to verify GFCI is working properly.

- 3 Supplementary Protector CB1
- 4 Supplementary Protector CB2

CB1 protects RC1 and the generator winding from overload. If CB1 opens, RC1 and GFCI1 do not work. Place switch in On position to reset.

CB2 protects GFCI1 from overload. If CB2 opens, GFCI1 does not work. Press button to reset.

Maximum output is 2.4 kVA/kW from GFCI1 and 4 kVA/kW from RC1. Maximum output from all receptacles is 4 kVA/kW.

EXAMPLE: If 13 A is drawn from RC1, only 7 A is available at GFCI1:

$$(240 \text{ V} \times 13 \text{ A}) + (120 \text{ V} \times 7 \text{ A}) = 4.0 \text{ kVA/kW}$$

7-2. Connecting To Three-Phase Generator

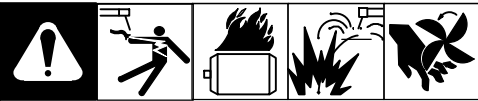

Single-Phase Power Connection

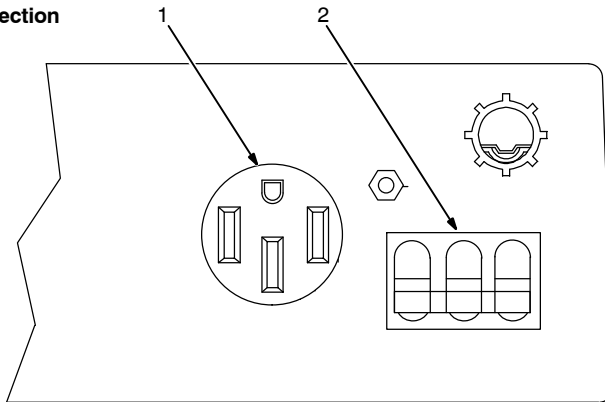

☞ Place Process/Contactor switch in Electrode Hot - Stick position when using three-phase generator (see Section 6-3).

Single-Phase Generator Power

- 1 120/240 V 50 A Receptacle RC5

RC5 is connected to the optional three-phase generator and supplies 60 Hz single-phase power at weld/power speed. Maximum power from RC5 is 12 kVA/kW. Power available at RC5 is reduced when welding.

- 2 Supplementary Protector CB7

CB7 protects single-phase receptacle RC5 and the load wires from overload. If CB7 opens, all three-phase generator output stops and the receptacle does not work.

Three-Phase Generator Power

⚠ Stop engine.

⚠ Power and weld outputs are live at the same time. Disconnect or insulate unused cables.

☞ Have qualified person install according to circuit diagram and Generator Power Guidelines in Owner's Manual.

Remove generator power panel mounting screws. Tilt panel forward.

Three-Phase Power Connection

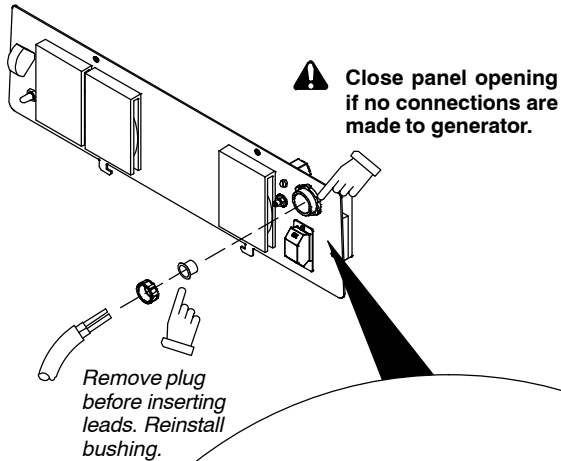

AC ~ Output	Single Phase 1 ~	Three Phase 3 ~
Volts	120/240	240
Amps	50	48
KVA/KW	12	20
Frequency	60 Hz	
Engine Speed	1850 RPM	

Lead 42 connects to GROUND stud on front of unit.
Jumper 42 is connected to 90 at factory.

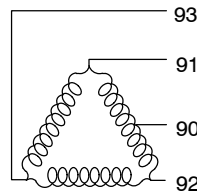

Remove plug before inserting leads. Reinstall bushing.

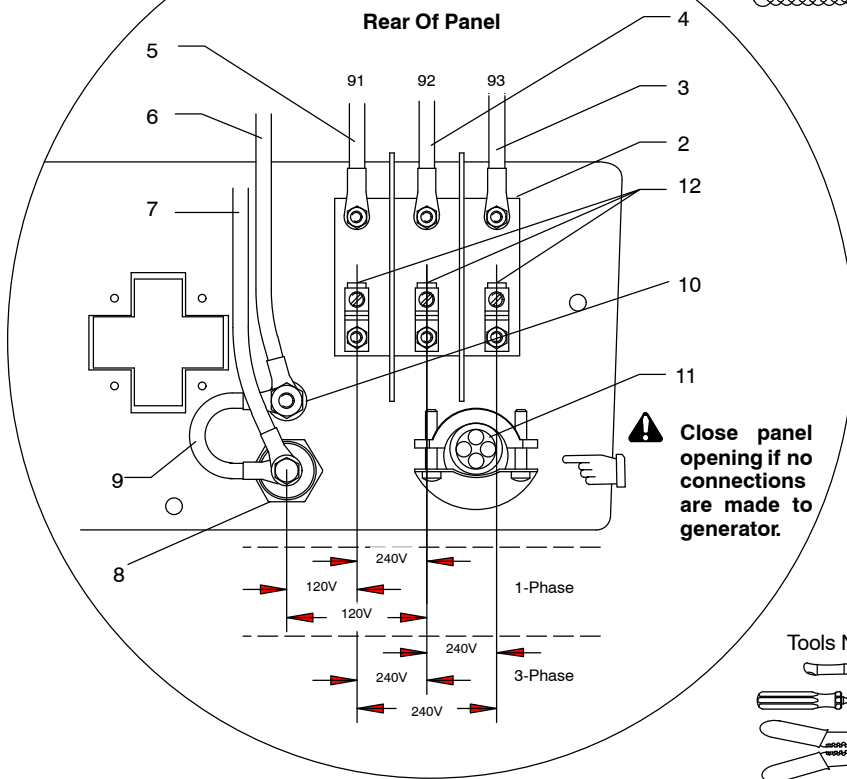

- 93
- 3 Lead 93
- 4 Lead 92
- 5 Lead 91
- 6 Lead 42 (Circuit Grounding Lead)
- 7 Lead 90 (Neutral)
- 8 Isolated Neutral Terminal
- 9 Jumper Lead 42
- 10 Grounding Terminal

Jumper 42 is connected to lead 90 at factory. Jumper 42 may be disconnected from neutral to meet applicable electrical codes.

Lead 42 connects to front panel Ground stud.

- 11 User-Supplied Leads

- 12 Supplementary Protector CB7 User Terminals

Connect user-supplied leads to terminals on CB7 and to the isolated neutral terminal and grounding terminal as necessary.

☞ CB7 protects single-phase receptacle RC5 and the load wires from overload. If CB7 opens, all three-phase generator output stops and the receptacle does not work.

Reinstall generator power panel.

Tools Needed:

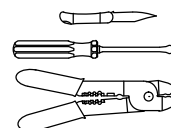

SECTION 8 – MAINTENANCE & TROUBLESHOOTING

8-1. Maintenance Label

<p>KUBOTA V3300BG DIESEL ENGINE</p> <p>12 V BCI 24 650 A @ -18C (0F)</p> <p>1850 RPM</p> <p>8 h std.</p> <p>DIESEL 93.7 L (24.75 gal)</p> <p>DIN 51 601 BS 2869: A1, A2 ASTM D 975-81: 1-D, 2-D VW-F 800C: DF-A, DF-1, DF-2 S < = .5%</p>		<p>100 h std.</p> <p>Clean air filter element if required.</p>		<p>200 h std.</p> <p>API: CD/CE/CF-4 13.2 L (14 qt)</p> <p>50 °C 104 °F</p> <p>Single Viscosity Oils</p> <p>5W, 10W, 15W, 20W, 20W, 30, 40, 50</p> <p>Multi-viscosity Oils</p> <p>5W-20, 5W-30, 10W-30, 15W-40, 20W-50</p> <p>500 h std.</p> <p>13 mm (1/2 in)</p> <p>Kubota 1G517-97010 OEM 207712</p>		<p>800 h std.</p> <p>Kubota 16631-43560 OEM 207715</p> <p>Kubota 12581-43010 OEM 207714</p> <p>20° C (72° F) Intake and Exhaust 0.23-0.27 mm (0.0091-0.011 in)</p> <p>1500 h std.</p>		<p>1 yr std.</p> <p>(Optional) OEM 192 939 Donaldson P822769 WIX 46490</p> <p>OEM 192 938 Donaldson P822768 WIX 46489</p> <p>2 yrs std.</p> <p>50/50 antifreeze/water 10.4 L (11 qt)</p> <p>Thermostat Kubota 1C010-73010 OEM 207713</p> <p>206 999-A</p>	
--	--	---	--	---	--	---	--	---	--

8-2. Routine Maintenance

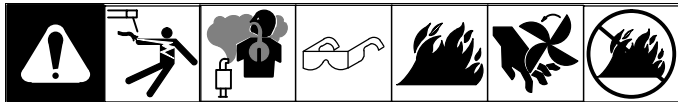

Recycle engine fluids.

Stop engine before maintaining.
 See Engine Manual and Maintenance Label for important start-up, service, and storage information. Service engine more often if used in severe conditions.

	✓ = Check	◇ = Change	● = Clean	☆ = Replace * To be done by Factory Authorized Service Agent	Reference
Every 8 Hours	 ✓ Coolant Level	 ✓ Fuel Level ● Sediment Bowl	 ✓ Oil Level	 ● Oil, Fuel Spills	Section 5-6
Every 50 Hours	 ✓ Fuel Connections	 ● Weld Terminals			
Every 100 Hours	 ● Air Cleaner Element	 ✓ Air Cleaner Hoses	 5/16 in. (8 mm) ✓ Belt Tension	 ● Battery Terminals	Section 8-3, Engine Manual
Every 200 Hours	 ✓ Oil ✓ Oil Filter	NOTICE – Change engine oil and filter after initial 50 to 75 hours of use. ◇ Oil ◇ Oil Filter	 ✓ Radiator Hoses	 ☆ Unreadable Labels	Section 8-7
Every 500 Hours	 ◇ Fan Belt	 ● Radiator Exterior	 ✓ ☆ Weld Cables	 ✓ ● Opt. Spark Arrestor	Engine Manual, Section 8-4, 8-8
Every 800 Hours	 ✓ Valve Clearance*	 ◇ Fuel Filter	 ● Fuel Sediment Filter		Section 8-7, Engine Manual
Every 1000 Hours	 ● Inside Unit	 SLUDGE FUEL ● Drain Sludge	 ✓ ☆ Brushes* ✓ ● Slip Rings*		Engine Manual, Section 8-5, 8-7
Every 1500 Hours	 ✓ Injectors				
Every Year	 ✓ ☆ Air Filter Elements				Section 8-3
Every 2 Years	 ✓ ☆ Coolant And Hoses				Section 8-8, Engine Manual

8-3. Servicing Air Cleaner

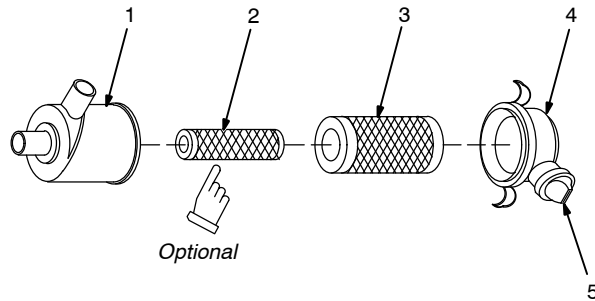
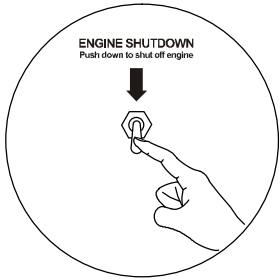

⚠ Stop engine.

NOTICE – Do not run engine without air cleaner or with dirty element. Engine damage caused by using a damaged element is not covered by the warranty.

☞ The air cleaner primary element can be cleaned but the dirt holding capacity of the filter is reduced with each cleaning. The chance of dirt reaching the clean side of the filter while cleaning and the possibility of filter damage makes cleaning a risk. Consider the risk of unwarrantable equipment damage when determining whether to clean or replace the primary element.

If you decide to clean the primary element, we strongly recommend installing an optional safety element to provide additional engine protection. **Never clean a safety element.** Replace the safety element after servicing the primary element three times.

Clean or replace primary element if dirty (see note above before cleaning). **Replace** primary element if damaged. Replace primary element yearly or after six cleanings.

- 1 Housing
- 2 Safety Element (Optional)
- 3 Primary Element
- 4 Dust Cap
- 5 Dust Ejector

To clean air filter:

Wipe off cap and housing. Remove cap and dump out dust. Remove element(s). Wipe dust from inside cap and housing with damp cloth. Reinstall safety element (if present). Reinstall cap.

NOTICE – Do not clean housing with air hose.

Clean primary element with compressed air only.

Air pressure must not exceed 100 psi (690 kPa). Use 1/8 in. (3 mm) nozzle and keep nozzle at least 2 in. (51 mm) from inside of element. Replace primary element if it has holes or damaged gaskets.

Reinstall primary element and cap (dust ejector down).

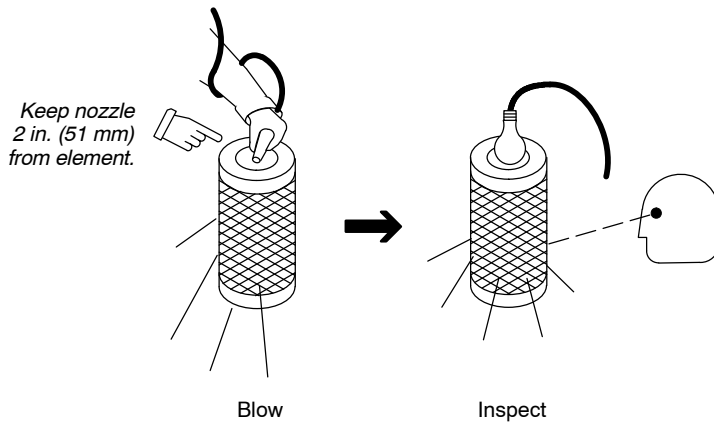

8-4. Inspecting/Cleaning Optional Spark Arrestor

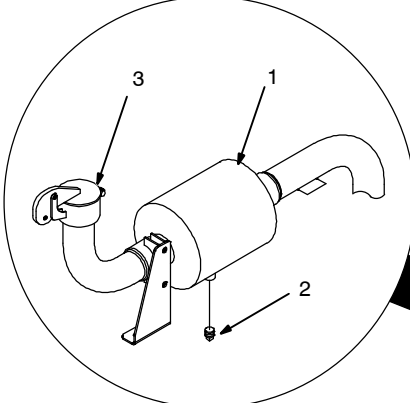
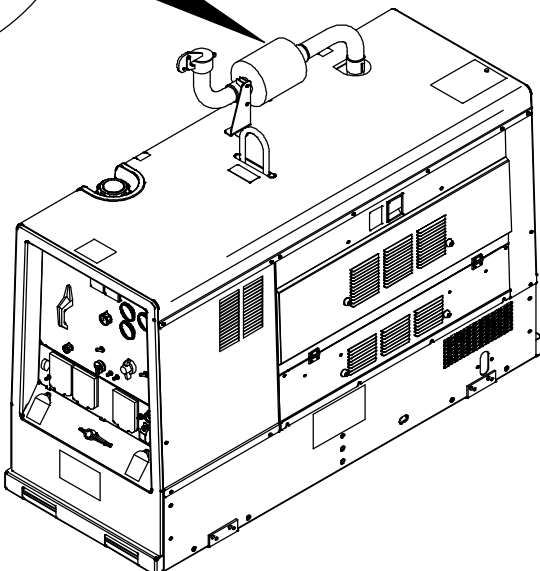
ENGINE SHUTDOWN
Push down to shut off engine

⚠ Stop engine and let cool.

- 1 Spark Arrestor Muffler
- 2 Cleanout Plug
- 3 Exhaust Pipe With Rain Cap

Remove plug and remove any dirt covering cleanout hole.

Start engine and run at idle speed to blow out cleanout hole. If nothing blows out of hole, briefly cover end of exhaust pipe with fireproof material.

⚠ Stop engine and let cool.

Reinstall cleanout plug.

Tools Needed:
 3/8 in.

Ref. 242 336-A / 804 582-A

8-5. Checking Generator Brushes

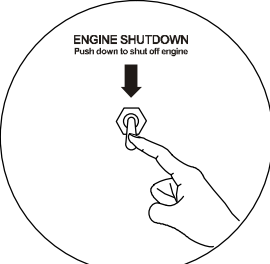
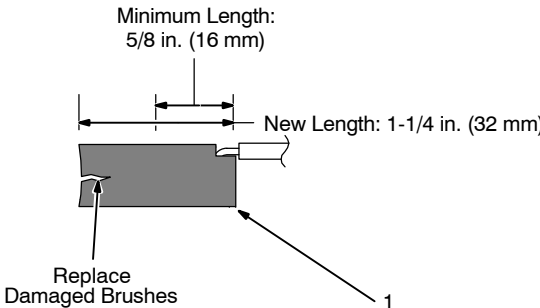
ENGINE SHUTDOWN
Push down to shut off engine

⚠ Stop engine and let cool.

- 1 Generator Brush

Remove brushes from brush holder.

Replace brushes if damaged or if brush material is at or near minimum length.

Minimum Length:
5/8 in. (16 mm)

New Length: 1-1/4 in. (32 mm)

Replace Damaged Brushes

8-6. Adjusting Engine Speed

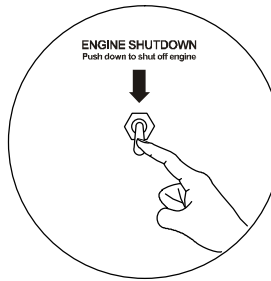
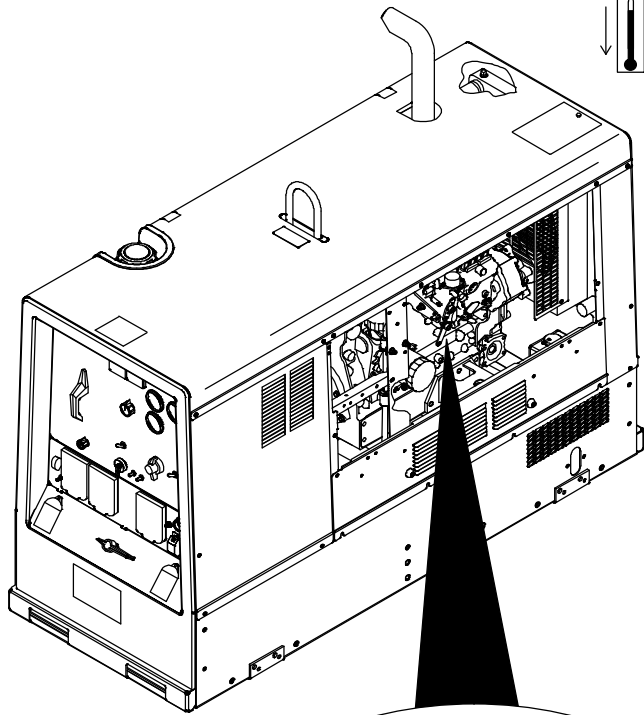

⚠ Stop engine and let cool.

Engine speed is factory set and should not require adjustment. After tuning engine, check engine no load speed with a tachometer or frequency meter (see table for no load speeds). If necessary, adjust speed as follows:

Start engine and run until warm.

Turn Process/Contactor Control switch to Stick - Electrode Hot position.

1 Engine Speed Adjustment Screw

2 Locking Nut

Loosen nut. Turn screw until engine runs at weld/power speed. Tighten nut.



⚠ Do not set engine speed higher than specified.

3 Engine Shutdown Lever

Use lever to stop engine if Engine Shutdown switch does not work.

⚠ Stop engine.

Close door.

	
	1850 rpm Max. (61.6 Hz)

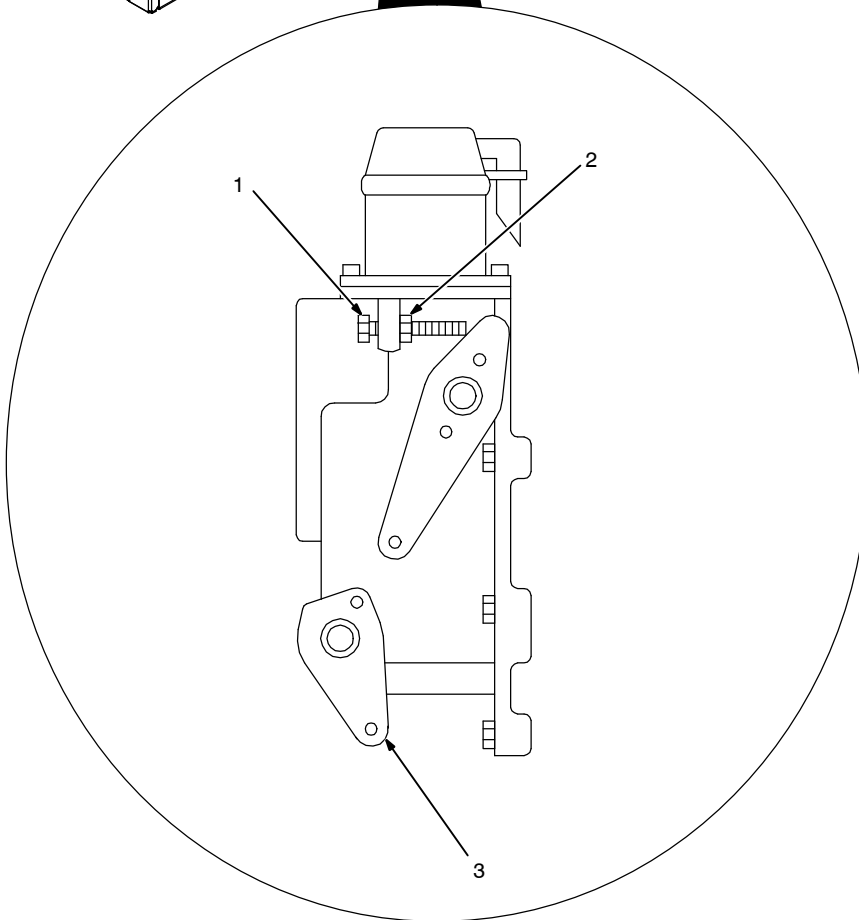

Tools Needed:

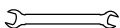

8-7. Servicing Fuel And Lubrication Systems

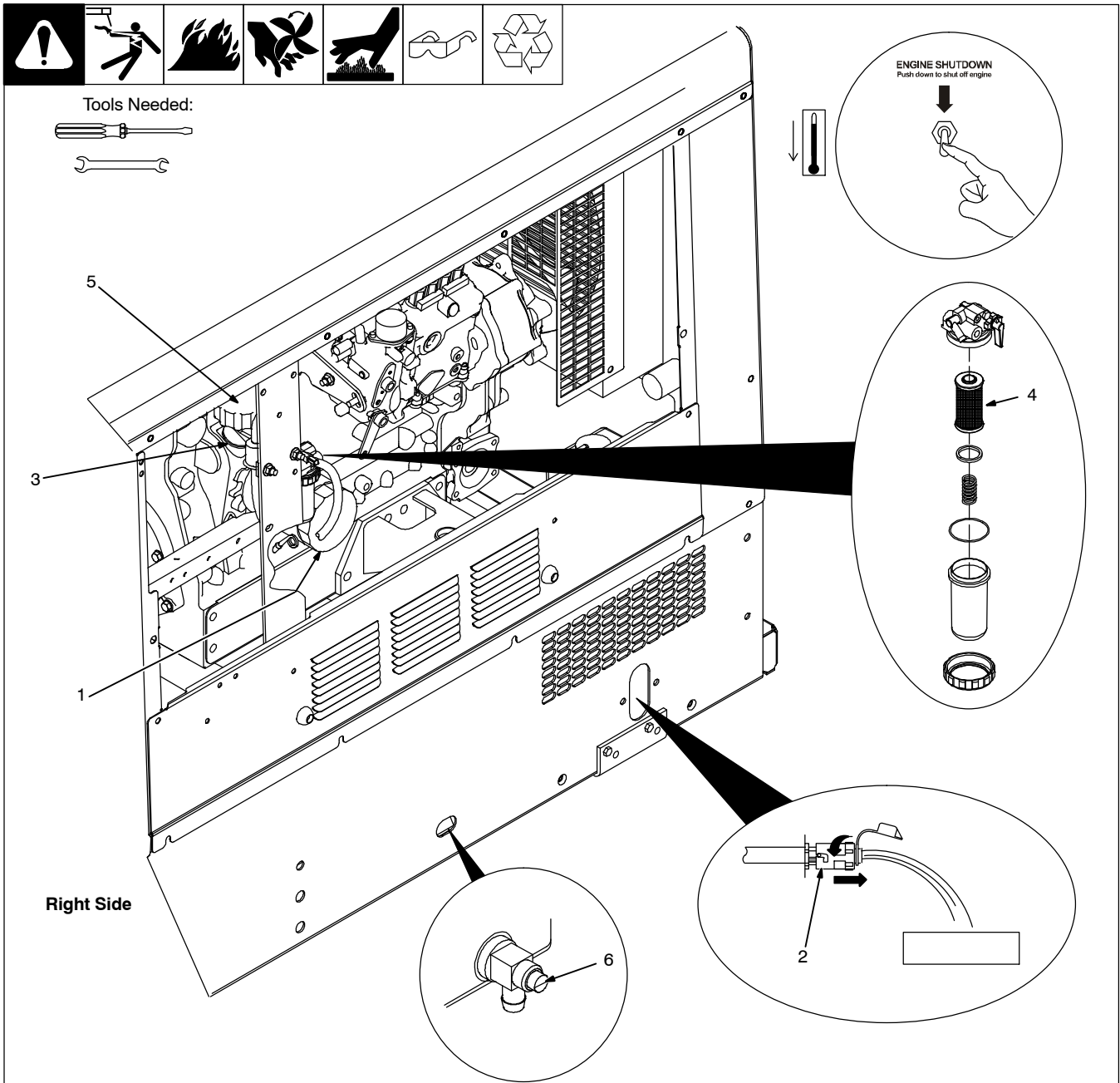

Tools Needed:

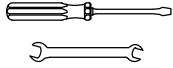

Right Side

Ref. 800 159-E / Ref. 802 170 / 804 583-B

⚠ Stop engine and let cool.

⚠ After servicing, start engine and check for fuel leaks. Stop engine, tighten connections as necessary, and wipe up spilled fuel.

- 1 Oil Filter
- 2 Oil Drain Valve And Hose
- 3 Oil Fill Cap
- 4 Fuel Sedimenter
- 5 Secondary Fuel Filter
- 6 Fuel Tank Sludge Drain Valve

To change oil and filter:

Route oil drain hose and valve through hole in base. See engine manual and engine maintenance label for oil/filter change information.

To drain water from fuel sedimenter:

Close fuel valve on top of sedimenter. Remove bowl and dump water that has collected in bowl. Clean sedimenter filter according to maintenance label.

To replace secondary fuel filter:

Turn filter counterclockwise. Remove filter.

Apply thin coat of fuel to gasket on new filter. Fill filter with fuel. Install filter and turn clockwise. Bleed air from fuel system according to engine manual.

Inspect fuel line, and replace if cracked or worn.

Close doors.

To drain sludge from fuel tank:

⚠ Beware of fire. Do not smoke and keep sparks and flames away from drained fuel. Dispose of drained fuel in an environmentally-safe manner. Do not leave unit unattended while draining fuel tank.

⚠ Properly lift unit and secure in a level position. Use adequate blocks or stands to support unit while draining fuel tank.

Attach 1/2 ID hose to drain valve. Put metal container under drain, and use screwdriver to open sludge drain valve. Close valve when sludge has drained. Remove hose.

8-8. Servicing Engine Cooling System

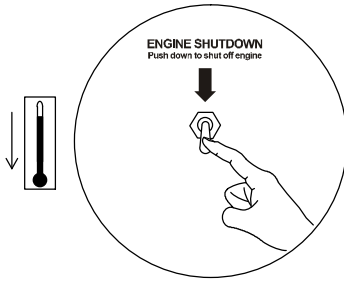

Tools Needed:
 3/8 in.

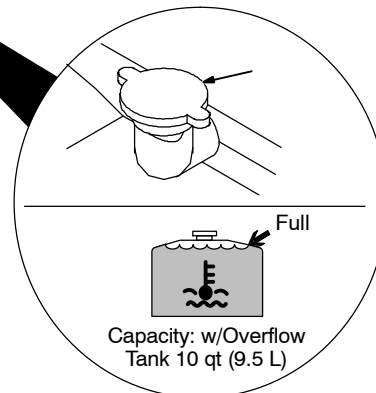
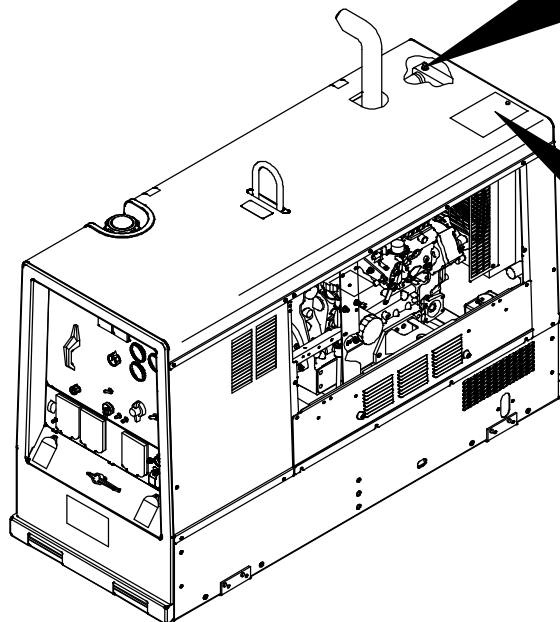
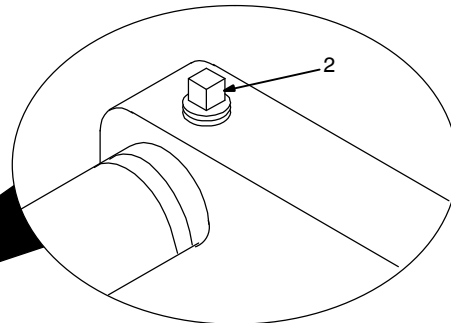
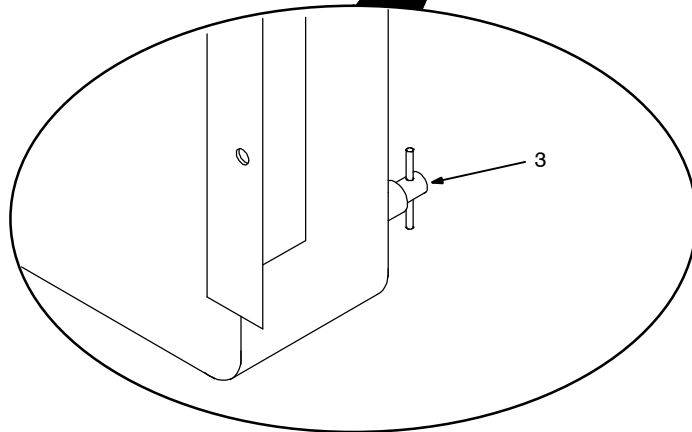
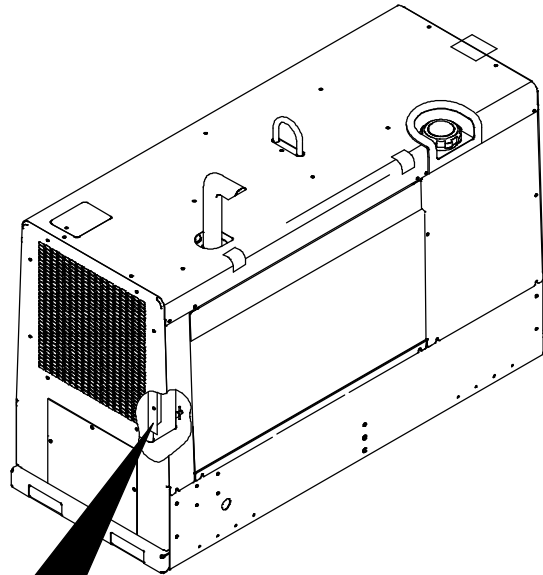

Stop engine and let cool.

- 1 Radiator Cap
- 2 Radiator Air Bleed Screw
- 3 Radiator Drain Cock

Drain engine coolant according to procedure in engine manual.

 Check coolant level according to Section 5-9 before starting this procedure.

Engine coolant is a mixture of water and ethylene glycol base antifreeze. A solution of 50% antifreeze and 50% water must be used in this engine. Do not use 100% antifreeze or severe damage will occur.

If changing coolant or if coolant level is below bottom of radiator filler neck, add coolant as follows:

Remove air bleed screw. Add coolant to radiator until coolant is at bottom of filler neck. This ensures all air is purged from the system.

Reinstall air bleed screw and radiator cap. Check coolant level in recovery tank (see Section 5-9).

8-9. Overload Protection

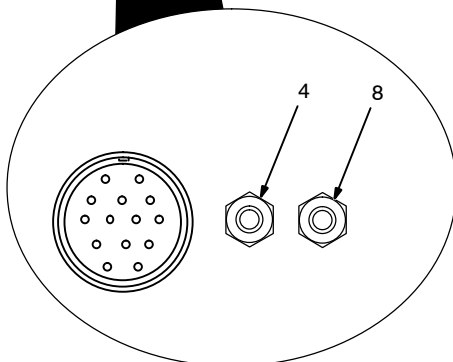
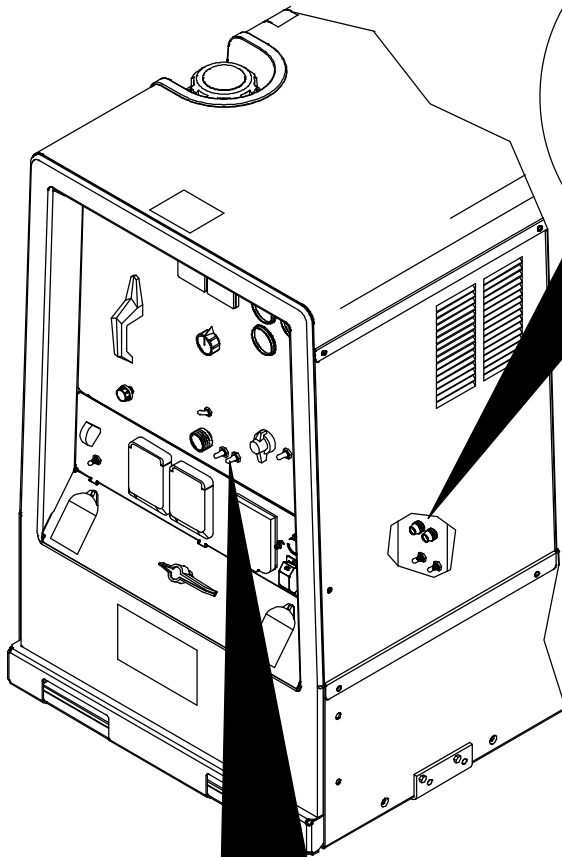
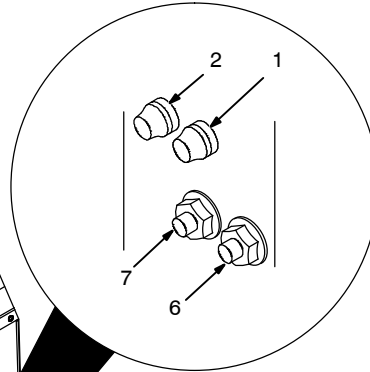
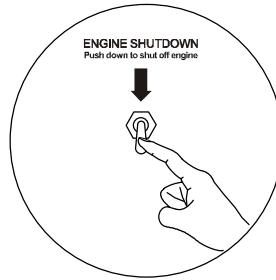

⚠ Stop engine.

- 1 Fuse F1
- 2 Fuse F2

F1 and F2 protect the stator exciter winding from overload. If F1 opens, weld and generator power is low or stops entirely. If F2 opens, weld output stops. 4 kVA/kW generator power is still available.

- 3 Circuit Breaker CB4 (Not Shown)
- 4 Supplementary Protector CB5
- 5 Circuit Breaker CB10 (Not Shown)
- 6 Supplementary Protector CB11
- 7 Supplementary Protector CB12
- 8 Supplementary Protector CB13

CB4 protects the welding arc drive (dig) circuit. If CB4 opens, the electrode may stick to the workpiece more frequently during low voltage (short arc length) conditions. CB4 automatically resets when the fault is corrected.

CB5 protects the 24 volt AC output to remote receptacle RC14, and 24 volt output to field current regulator board PC1. If CB5 opens, weld output and 24 volt output to RC14 stops.

CB10 protects the engine battery circuit. If CB10 opens, the engine will not crank. CB10 automatically resets when the fault is corrected.

CB11 protects the control box wiring harness. If CB11 opens, weld output stops (generator power is still available).

CB12 protects the field flashing circuit. If CB12 opens, the generator may not excite at start-up and weld and generator power output may not be available.

CB13 protects the 115 volt AC output to remote receptacle RC14. If CB13 opens, 115 volt output to RC14 stops.

Press button to reset supplementary protector.

8-10. Troubleshooting Tables

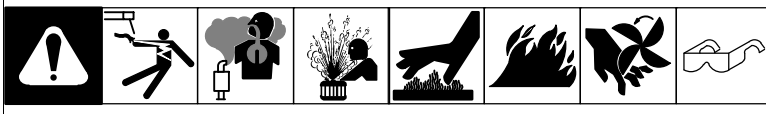

A. Welding

Trouble	Remedy
No weld output; generator power output okay at AC receptacles.	Place Process/Contactor switch S6 in a Weld Terminals Always On position, or place switch in a Weld Terminals Remotely Controlled position and connect remote contactor to optional Remote 14 receptacle RC14 (see Sections 5-13, 6-3 and 6-4).
	Check position of Amperage Range switch S3.
	Check position of optional Polarity/AC Selector switch S13.
	Reset supplementary protector CB11 (see Section 8-9).
	Reset supplementary protector CB5 (see Section 8-9). Check for faulty remote device connected to RC14.
	Check fuse F2, and replace if open (see Section 8-9).
	Check and secure connections to Remote 14 receptacle RC14 (see Section 5-13). Have Factory Authorized Service Agent check connector board PC6 and connections; brushes and slip rings; field excitation circuit; field current regulator board PC1; and the rotor.
No weld output or generator power output at AC receptacles.	Disconnect equipment from generator power receptacles during start-up.
	Reset supplementary protector CB12 (see Section 8-9).
	Check fuses F1 and F2, and replace if open (see Section 8-9).
	Have Factory Authorized Service Agent check integrated rectifier SR1, capacitor C9, field current regulator board PC1, and rotor.
Erratic weld output.	Use dry, properly stored electrodes.
	Be sure connection to work piece is clean and tight.
	Remove excessive coils from weld cables.
	Check and tighten connections inside and outside unit.
High weld output.	Check position of Amperage Range switch S3 and Voltage/Amperage Adjust control R1.
	Check engine speed, and adjust if necessary (see Section 8-6).
	Have Factory Authorized Service Agent check field current regulator board PC1.
Electrode sticks to the workpiece more frequently during low voltage (short arc length) conditions.	Circuit breaker CB4 may be open. CB4 automatically resets when the fault is corrected (see Section 8-9). Have Factory Authorized Service Agent check transformer T1 and integrated rectifiers SR4 and SR5.
Low weld output.	Check engine speed, and adjust if necessary (see Section 8-6).
	Check fuses F1 and F2, and replace if open (see Section 8-9). Have Factory Authorized Service Agent check integrated rectifier SR1, capacitor C9, field current regulator board PC1, and rotor.
Low open-circuit voltage.	Check engine speed, and adjust if necessary (see Section 8-6).
No remote fine amperage or voltage control.	Place Voltage/Amperage Adjust Control switch S5 in Weld Terminals Remotely Controlled position.
	Check and secure connections to Remote 14 receptacle RC14 (see Section 5-13).
	Repair or replace remote control device.
Wire feeder does not work with welding generator.	Reset supplementary protector CB5 or CB6 (see Section 8-9).
	Check and secure connections to Remote 14 receptacle RC14 (see Section 5-13).

Trouble	Remedy
	Repair or replace wire feeder.
Low CV weld output.	Set Amperage Range switch S3 to highest range.
Min or max CV weld output only.	Check position of Voltage/Amperage Adjust control R1 and Voltage/Amperage Adjust Control switch S5.
	Repair or replace remote control device.
	Have Factory Authorized Service Agent check field current regulator board PC1 and connections.

B. Standard Generator Power

Trouble	Remedy
No generator power output at AC receptacles; weld output okay.	Reset receptacle supplementary protectors.
No generator power output at AC receptacles; no weld output.	Disconnect equipment from generator power AC receptacles during start-up.
	Reset supplementary protector CB12 (see Section 8-9). Have Factory Authorized Service Agent check field current regulator board PC1.
	Check fuses F1 and F2, and replace if open (see Section 8-9). Have Factory Authorized Service Agent check integrated rectifier SR1, capacitor C9, and rotor.
	Have Factory Authorized Service Agent check slip rings, install new brushes if necessary, and check field excitation circuit.
High output at generator power AC receptacles.	Check engine speed, and adjust if necessary (see Section 8-6).
	Have Factory Authorized Service Agent adjust generator power field current resistor R3.
Low output at generator power AC receptacles.	Check engine speed, and adjust if necessary (see Section 8-6).
	Check fuse F1, and replace if open (see Section 8-9). Have Factory Authorized Service Agent check integrated rectifier SR1, resistor R3, and Capacitor C9.

C. Three-Phase Generator Power

Trouble	Remedy
No or low output at optional three-phase generator/receptacle RC5.	Place Process/Contactor switch in Weld Terminals Always On - Stick position (see Section 6-3).
	Reset supplementary protector CB7 (see Section 7-2).
	Reset supplementary protector CB5 (see Section 8-9).
	Check engine weld/power speed, and adjust if necessary (see Section 8-6).
	Have Factory Authorized Service Agent check brushes and slip rings, and field current regulator board PC1.
High output at optional three-phase generator/receptacle RC5.	Check engine weld/power speed, and adjust if necessary (see Section 8-6).
	Have Factory Authorized Service Agent check field current regulator board PC1, and PC1 voltage feedback circuit.
Erratic output at optional three-phase generator/receptacle RC5.	Have Factory Authorized Service Agent check brushes and slip rings, and field current regulator board PC1.

D. Engine

Trouble	Remedy
Engine will not crank.	Check battery, and replace if necessary.
	Check battery connections and tighten if necessary.
	Circuit breaker CB10 may be open. CB10 automatically resets when fault is corrected (see Section 8-9). Check engine wiring harness and components.

Trouble	Remedy
	<p>Check engine wiring harness plug connections.</p> <p>Have Factory Authorized Service Agent check continuity of Engine Start/Preheat switch S1, and replace if necessary.</p>
Engine cranks but does not start.	<p>Check fuel level.</p> <p>Check battery and replace if necessary. Check engine charging system according to engine manual.</p> <p>Have Factory Authorized Service Agent check electric fuel pump, fuel solenoid FS1, control relays CR1 and CR2, engine oil pressure switch S12, engine coolant temperature switch, fuel/hour gauge, and Engine Shutdown switch S7.</p> <p>Air in fuel system. See engine manual.</p>
Engine starts, but stops when Start/Preheat switch S1 is released.	<p>Check coolant level. Automatic shutdown system stops engine if engine temperature is too high (see Sections 5-9).</p> <p>Have Factory Authorized Service Agent check fuel/hour gauge and control relay CR5.</p>
Engine hard to start in cold weather.	<p>Turn Start/Preheat switch S1 to Preheat position before starting (see Section or 6-1).</p> <p>Have Factory Authorized Service Agent check glow plug and related wiring.</p> <p>Keep battery in good condition. Store battery in warm area off cold surface.</p> <p>Use fuel formulated for cold weather (diesel fuel can gel in cold weather). Contact local fuel supplier for fuel information.</p> <p>Use correct grade oil for cold weather (see Section 8-1).</p>
Engine suddenly stops.	<p>Check fuel level.</p> <p>Check oil level. Automatic shutdown system stops engine if oil pressure is too low (see Sections 5-9).</p> <p>Check coolant level. Automatic shutdown system stops engine if engine temperature is too high (see Sections 5-9).</p> <p>Have Factory Authorized Service Agent check control relay CR2 and fuel solenoid FS1.</p>
Engine slowly stopped and cannot be restarted.	<p>Check fuel level.</p> <p>Check engine air and fuel filters (see Sections 8-3 and 8-7).</p> <p>See engine manual.</p>
Battery discharges between uses.	<p>Clean top of battery with baking soda and water solution; rinse with clear water.</p> <p>Recharge or replace battery if necessary.</p> <p>Periodically recharge battery (approximately every 3 months).</p>
Engine uses oil during run-in period; wetstacking occurs.	<p>Dry engine (see Section 10).</p>

SECTION 9 - ELECTRICAL DIAGRAM

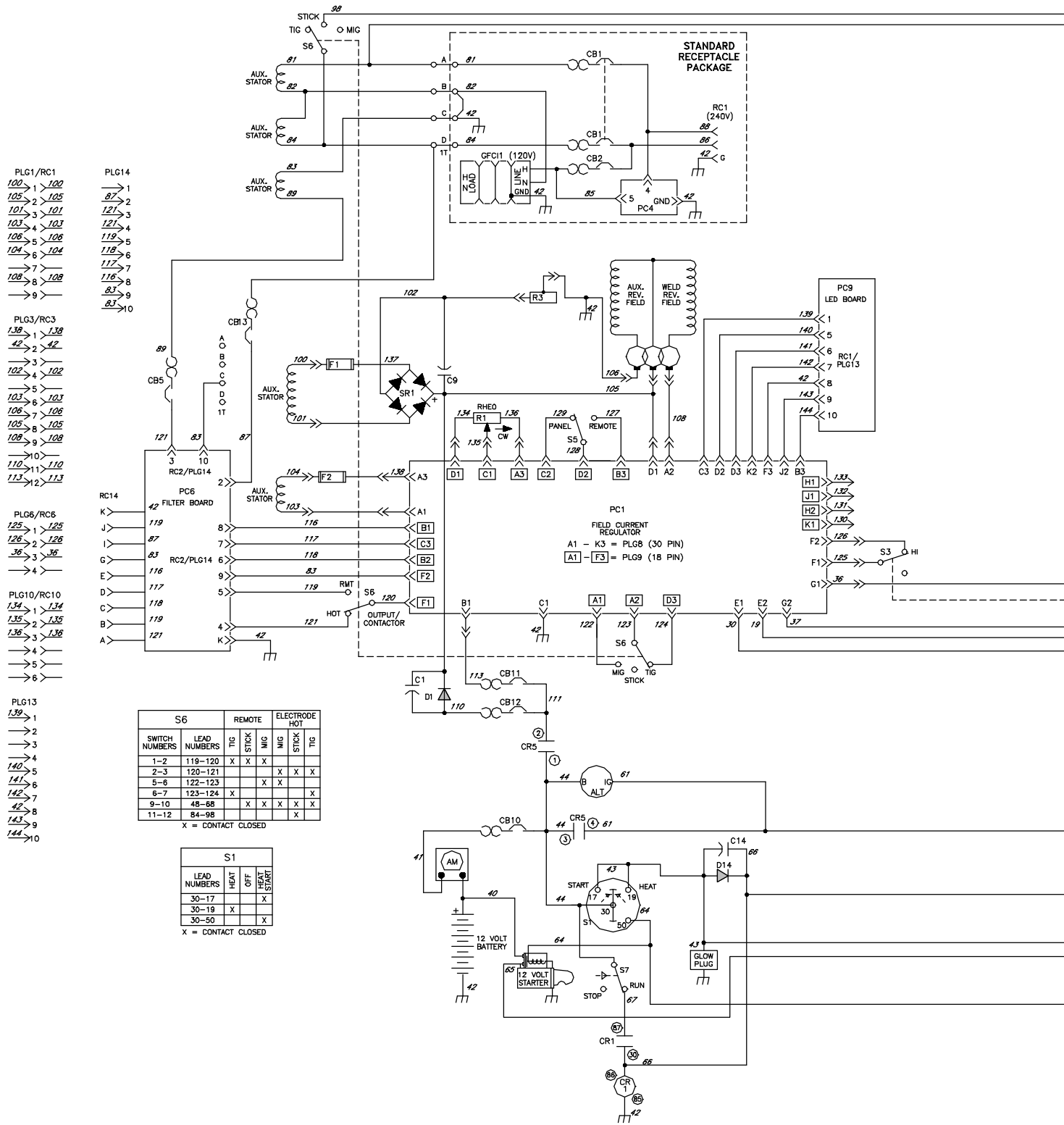

S6		REMOTE		ELECTRODE HOT		
SWITCH NUMBERS	LEAD NUMBERS	TIG	STICK	MIG	STICK	TIG
1-2	119-120	X	X	X	X	X
2-3	120-121			X	X	X
5-6	122-123			X	X	
6-7	123-124	X		X	X	X
9-10	48-88	X	X	X	X	X
11-12	84-98			X	X	

X = CONTACT CLOSED

S1		HEAT	OFF	HEAT
LEAD NUMBERS	HEAT	OFF	HEAT	START
30-17			X	
30-19	X			
30-50				X

X = CONTACT CLOSED

Figure 9-1. Circuit Diagram For Welding Generator

⚠ WARNING



ELECTRIC SHOCK HAZARD

- Do not touch live electrical parts.
- Disconnect input power or stop engine before servicing.
- Do not operate with covers removed.
- Have only qualified persons install, use, or service this unit.

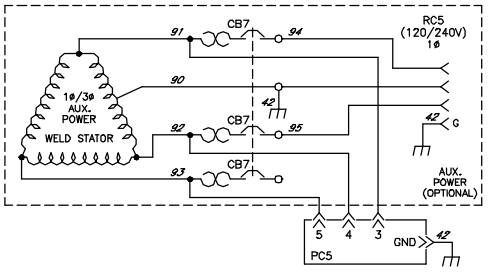

- MACHINE WIRE NUMBERS**
- 10-39 = WELD SECONDARY
 - 40-79 = ENGINE CONTROLS (EXCEPT 42 = CHASSIS)
 - 80-99 = AUX. SECONDARY
 - 100-149 = EXCITER/CONTROL

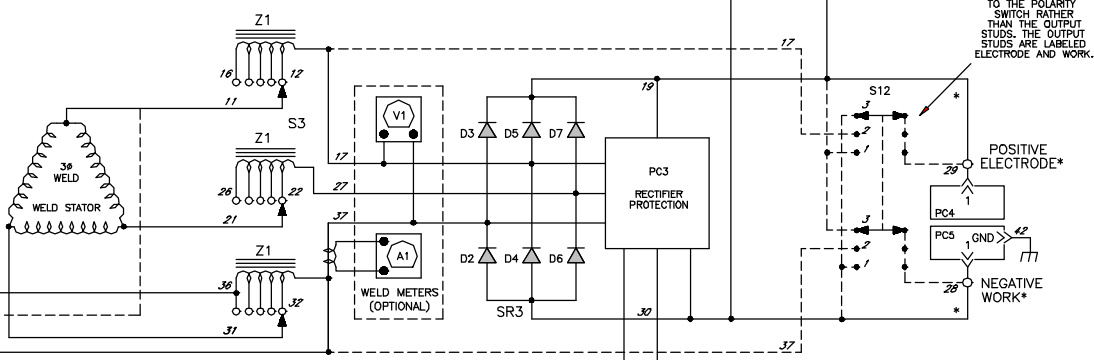

POLARITY SWITCH (OPTIONAL)
 * WITH THE POLARITY SWITCH OPTION, LEADS 19 & 30 GO TO THE POLARITY SWITCH RATHER THAN THE OUTPUT STUDS. THE OUTPUT STUDS ARE LABELED ELECTRODE AND WORK.

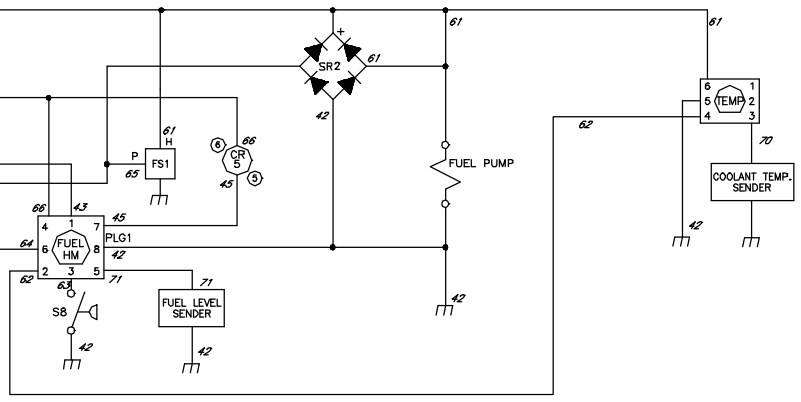
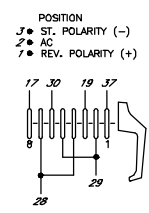
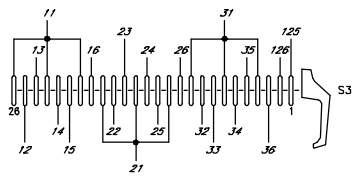

SECTION 10 – RUN-IN PROCEDURE

run_in1 2007-04

10-1. Wetstacking

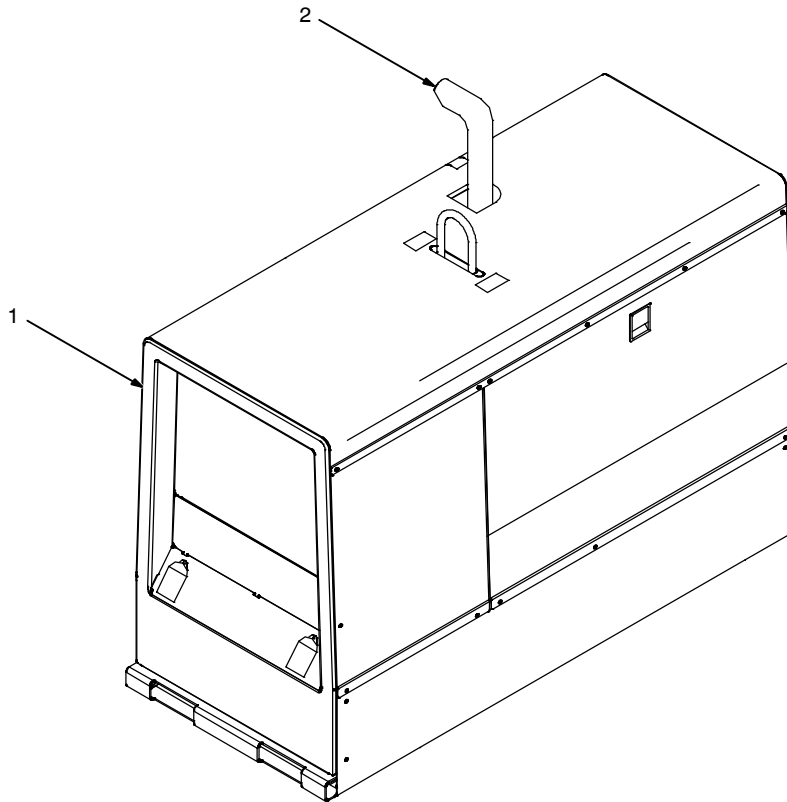

NOTICE – Do not perform run-in procedure at less than 20 volts weld output and do not exceed duty cycle or equipment damage may occur.

1 Welding Generator

Run diesel engines near rated voltage and current during run-in period to properly seat piston rings and prevent wetstacking. See nameplate, rating label, or specifications section in this manual to find rated voltage and current.

NOTICE – Do not idle engine longer than necessary. Piston rings seat faster if engine runs at weld/power rpm, and the welding generator is kept loaded during run-in.

2 Engine Exhaust Pipe

Wetstacking is unburned fuel and oil in the exhaust pipe and occurs during run-in if the engine is run too long at light load or idle rpm.

If exhaust pipe is coated with a wet, black, tar-like substance, dry the engine using one of the following run-in procedures.

See the engine manual for additional engine run-in information.

10-2. Run-In Procedure Using Load Bank

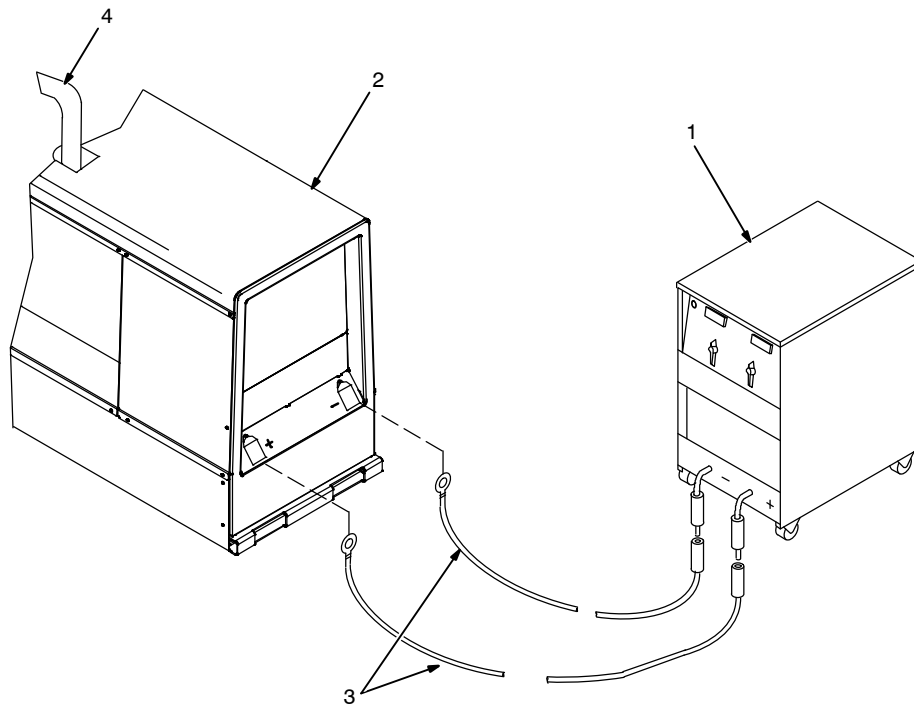

- Stop engine.**
- Do not touch hot exhaust pipe, engine parts, or load bank/grid.**
- Keep exhaust and pipe away from flammables.**

NOTICE – Do not perform run-in procedure at less than 20 volts weld output and do not exceed duty cycle or equipment damage may occur.

1 Load Bank

Turn all load bank switches Off. If needed, connect load bank to 115 volts ac wall receptacle or generator auxiliary power receptacle.

2 Welding Generator

Place A/V range switch in maximum position, A/V control in minimum position, and Output Selector switch (if present) in either DC position.

3 Weld Cables

Connect load bank to generator weld output terminals using proper size weld cables with correct connectors. Observe correct polarity.

Start engine and run for several minutes.

Set load bank switches and then adjust generator A/V control so load equals rated voltage and current of generator (see nameplate, rating label, or the specifications section in this manual).

Check generator and load bank meters after first five minutes then every fifteen minutes to be sure generator is loaded properly.

NOTICE – Check oil level frequently during run-in; add oil if needed.

It is recommended to run the welding generator for two hours minimum and up to four hours under load. Place A/V control in minimum position, then turn off load bank to remove load. Run engine several minutes at no load.

- Stop engine and let cool.**

4 Engine Exhaust Pipe

Repeat procedure if wetstacking is present.

10-3. Run-In Procedure Using Resistance Grid

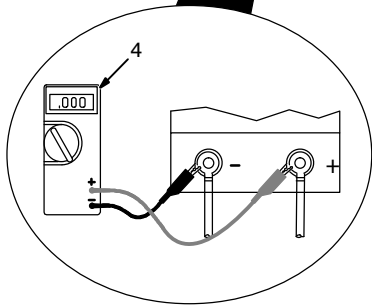
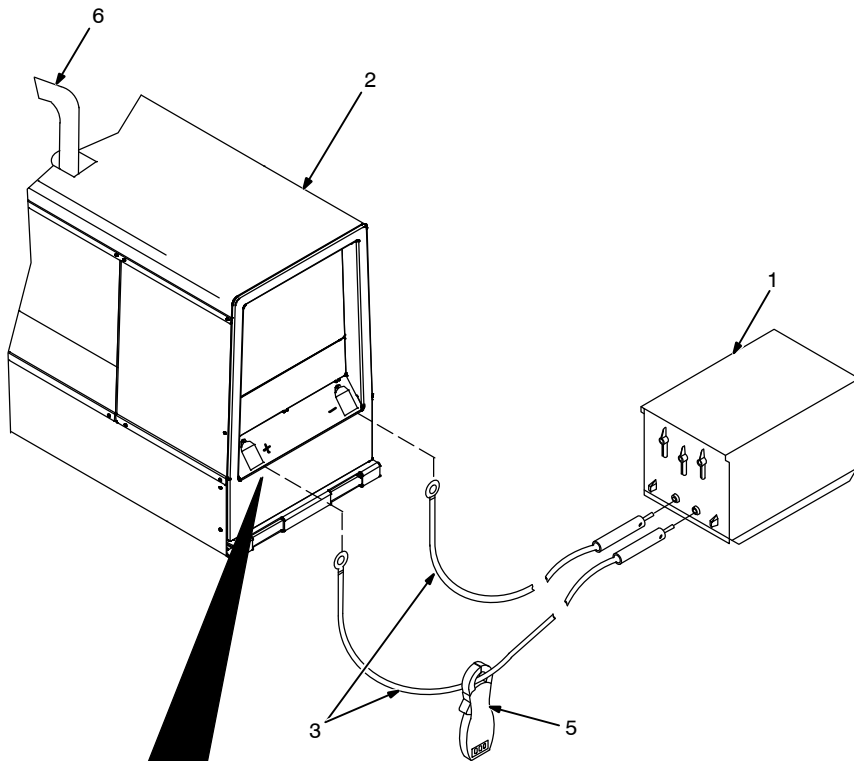

- Stop engine.**
- Do not touch hot exhaust pipe, engine parts, or load bank/grid.**
- Keep exhaust and pipe away from flammables.**

NOTICE – Do not perform run-in procedure at less than 20 volts weld output and do not exceed duty cycle or equipment damage may occur.

1 Resistance Grid

Use grid sized for generator rated output.

Turn Off grid.

2 Welding Generator

Place A/V range switch in maximum position, A/V control in minimum position, and Output Selector switch (if present) in either DC position.

3 Weld Cables

Connect grid to generator weld output terminals using proper size weld cables with correct connectors (polarity is not important).

4 Voltmeter

5 Clamp-On Ammeter

Connect voltmeter and ammeter as shown, if not provided on generator.

Start engine and run for several minutes.

Set grid switches and then adjust generator A/V control so load equals rated voltage and current of the generator (see nameplate, rating label, or the specifications section in this manual).

Check generator and meters after first five minutes then every fifteen minutes to be sure generator is loaded properly.

NOTICE – Check oil level frequently during run-in; add oil if needed.

It is recommended to run the welding generator for two hours minimum and up to four hours under load. Place A/V control in minimum position, then shut down grid to remove load. Run engine several minutes at no load.

- Stop engine and let cool.**

6 Engine Exhaust Pipe

Repeat procedure if wetstacking is present.

SECTION 11 – GENERATOR POWER GUIDELINES

 The views in this section are intended to be representative of all engine-driven welding generators. Your unit may differ from those shown.

11-1. Selecting Equipment

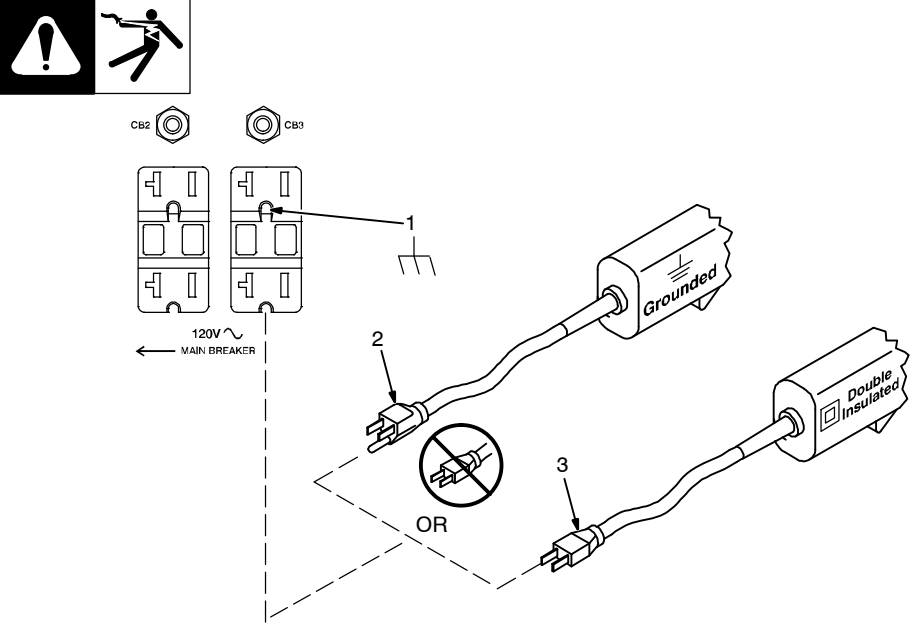

120V ~
MAIN BREAKER

OR

- 1 Generator Power Receptacles – Neutral Bonded To Frame
- 2 3-Prong Plug From Case Grounded Equipment
- 3 2-Prong Plug From Double Insulated Equipment

 Be sure equipment has double insulated symbol and/or wording on it.

 **Do not use 2-prong plug unless equipment is double insulated.**

gen_pwr 2011-04 – ST-800 577

11-2. Grounding Generator To Truck Or Trailer Frame

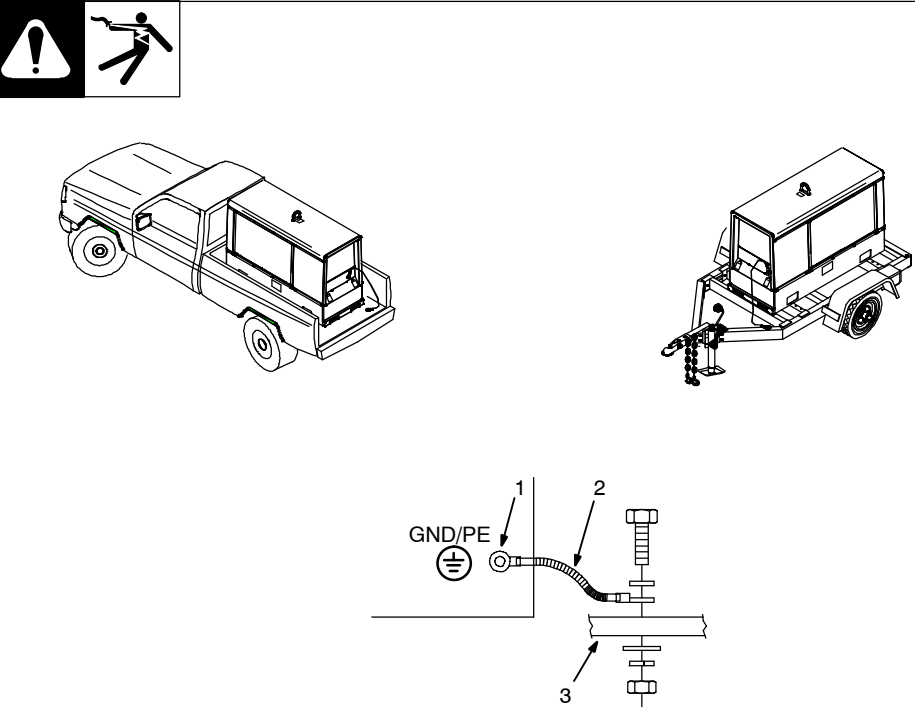

1
GND/PE

2

3

 **Always ground generator frame to vehicle frame to prevent electric shock and static electricity hazards.**

 **Also see AWS Safety & Health Fact Sheet No. 29, Grounding of Portable And Vehicle Mounted Welding Generators.**

- 1 Equipment Grounding Terminal (On Front Panel)
- 2 Grounding Cable (Not Supplied)
- 3 Metal Vehicle Frame

Connect cable from equipment ground terminal to metal vehicle frame. Use #8 AWG or larger insulated copper wire.

 *Electrically bond generator frame to vehicle frame by metal-to-metal contact.*

 **Bed liners, shipping skids, and some running gear insulate the welding generator from the vehicle frame. Always connect a ground wire from the generator equipment grounding terminal to bare metal on the vehicle frame as shown.**

 **Use GFCI protection when operating auxiliary equipment. If unit does not have GFCI receptacles, use GFCI-protected extension cord.**

800 652-D

11-3. Grounding When Supplying Building Systems

1 Equipment Grounding Terminal
2 Grounding Cable
Use #8 AWG or larger insulated copper wire.
3 Ground Device

Use ground device as stated in electrical codes.

⚠ Ground generator to system earth ground if supplying power to a premises (home, shop, farm) wiring system.

⚠ Also see AWS Safety & Health Fact Sheet No. 29, Grounding of Portable And Vehicle Mounted Welding Generators.

ST-800 576-B

11-4. How Much Power Does Equipment Require?

1 Resistive Load
A light bulb is a resistive load and requires a constant amount of power.

2 Non-Resistive Load
Equipment with a motor is a non-resistive load and requires approximately six times more power while starting the motor than when running (see Section 11-8).

3 Rating Data
Rating shows volts and amperes, or watts required to run equipment.

Amperes x Volts = Watts

Example 1: If a drill uses 4.5 amperes at 115 volts, calculate its running power requirement in watts.
 $4.5 \text{ A} \times 115 \text{ V} = 520 \text{ W}$
The load applied by the drill is 520 watts.

Example 2: If three 200 watt flood lamps are used with the drill from Example 1, add the individual loads to calculate total load.
 $(3 \times 200\text{W}) + 520 \text{ W} = 1120 \text{ W}$
The total load applied by the three flood lamps and drill is 1120 watts.

S-0623

11-5. Approximate Power Requirements For Industrial Motors

Industrial Motors	Rating	Starting Watts	Running Watts
Split Phase	1/8 HP	800	300
	1/6 HP	1225	500
	1/4 HP	1600	600
	1/3 HP	2100	700
	1/2 HP	3175	875
Capacitor Start-Induction Run	1/3 HP	2020	720
	1/2 HP	3075	975
	3/4 HP	4500	1400
	1 HP	6100	1600
	1-1/2 HP	8200	2200
	2 HP	10550	2850
	3 HP	15900	3900
Capacitor Start-Capacitor Run	5 HP	23300	6800
	1-1/2 HP	8100	2000
	5 HP	23300	6000
	7-1/2 HP	35000	8000
Fan Duty	10 HP	46700	10700
	1/8 HP	1000	400
	1/6 HP	1400	550
	1/4 HP	1850	650
	1/3 HP	2400	800
	1/2 HP	3500	1100

11-6. Approximate Power Requirements For Farm/Home Equipment



Farm/Home Equipment	Rating	Starting Watts	Running Watts
Stock Tank De-Icer		1000	1000
Grain Cleaner	1/4 HP	1650	650
Portable Conveyor	1/2 HP	3400	1000
Grain Elevator	3/4 HP	4400	1400
Milk Cooler		2900	1100
Milker (Vacuum Pump)	2 HP	10500	2800
FARM DUTY MOTORS	1/3 HP	1720	720
Std. (e.g. Conveyors,	1/2 HP	2575	975
Feed Augers, Air	3/4 HP	4500	1400
Compressors)	1 HP	6100	1600
	1-1/2 HP	8200	2200
	2 HP	10550	2850
	3 HP	15900	3900
	5 HP	23300	6800
High Torque (e.g. Barn	1-1/2 HP	8100	2000
Cleaners, Silo Unloaders,	5 HP	23300	6000
Silo Hoists, Bunk Feeders)	7-1/2 HP	35000	8000
	10 HP	46700	10700
3-1/2 cu. ft. Mixer	1/2 HP	3300	1000
High Pressure 1.8 Gal/Min	500 PSI	3150	950
Washer 2 gal/min	550 PSI	4500	1400
2 gal/min	700 PSI	6100	1600
Refrigerator or Freezer		3100	800
Shallow Well Pump	1/3 HP	2150	750
	1/2 HP	3100	1000
Sump Pump	1/3 HP	2100	800
	1/2 HP	3200	1050

11-7. Approximate Power Requirements For Contractor Equipment

Contractor	Rating	Starting Watts	Running Watts
Hand Drill	1/4 in	350	350
	3/8 in	400	400
	1/2 in	600	600
Circular Saw	6-1/2 in	500	500
	7-1/4 in	900	900
	8-1/4 in	1400	1400
Table Saw	9 in	4500	1500
	10 in	6300	1800
Band Saw	14 in	2500	1100
Bench Grinder	6 in	1720	720
	8 in	3900	1400
	10 in	5200	1600
Air Compressor	1/2 HP	3000	1000
	1 HP	6000	1500
	1-1/2 HP	8200	2200
	2 HP	10500	2800
Electric Chain Saw	1-1/2 HP, 12 in	1100	1100
	2 HP, 14 in	1100	1100
Electric Trimmer	Standard 9 in	350	350
	Heavy Duty 12 in	500	500
Electric Cultivator	1/3 HP	2100	700
Elec. Hedge Trimmer	18 in	400	400
Flood Lights	HID	125	100
	Metal Halide	313	250
	Mercury	1000	
	Sodium Vapor	1400	1000
Submersible Pump	400 gph	600	200
Centrifugal Pump	900 gph	900	500
Floor Polisher	3/4 HP, 16 in	4500	1400
	1 HP, 20 in	6100	1600
High Pressure Washer	1/2 HP	3150	950
	3/4 HP	4500	1400
	1 HP	6100	1600
55 gal Drum Mixer	1/4 HP	1900	700
Wet & Dry Vac	1.7 HP	900	900
	2-1/2 HP	1300	1300

11-8. Power Required To Start Motor

Single-Phase Induction Motor Starting Requirements								
Motor Start Code	G	H	J	K	L	M	N	P
KVA/HP	6.3	7.1	8.0	9.0	10.0	11.2	12.5	14.0

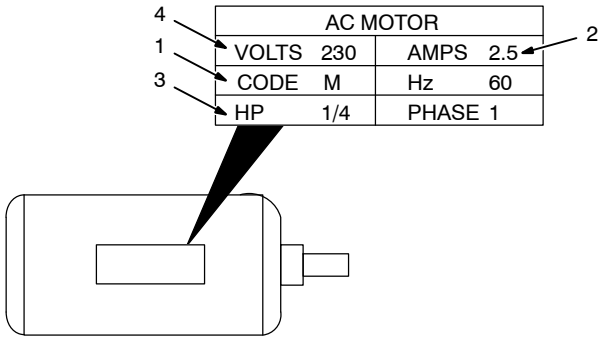

AC MOTOR			
VOLTS	230	AMPS	2.5
CODE	M	Hz	60
HP	1/4	PHASE	1

- 1 Motor Start Code
- 2 Running Amperage
- 3 Motor HP
- 4 Motor Voltage

To find starting amperage:

Step 1: Find code and use table to find kVA/HP. If code is not listed, multiply running amperage by six to find starting amperage.

Step 2: Find Motor HP and Volts.

Step 3: Determine starting amperage (see example).

Welding generator amperage output must be at least twice the motor's running amperage.

(kVA/HP x HP x 1000) / Volts = Starting Amperage

Example: Calculate starting amperage required for a 230 V, 1/4 HP motor with a motor start code of M.



Volts = 230, HP = 1/4, kVA/HP = 11.2

$(11.2 \times 1/4 \times 1000) / 230 = 12.2A$

Starting the motor requires 12.2 amperes.

S-0624

11-9. How Much Power Can Generator Supply?

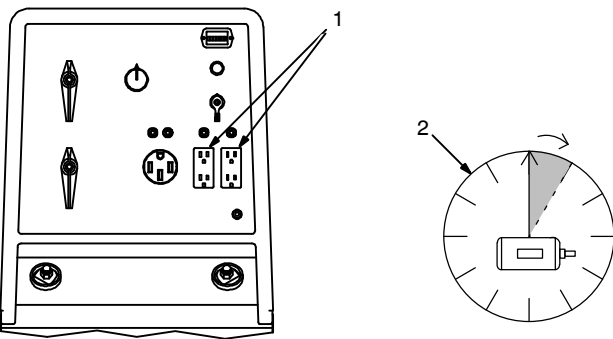

- 1 Limit Load To 90% Of Generator Output

Always start non-resistive (motor) loads in order from largest to smallest, and add resistive loads last.

- 2 5 Second Rule

If motor does not start within 5 seconds, turn off power to prevent motor damage. Motor requires more power than generator can supply.

Ref. ST-800 396-A / S-0625

11-10. Typical Connections To Supply Standby Power

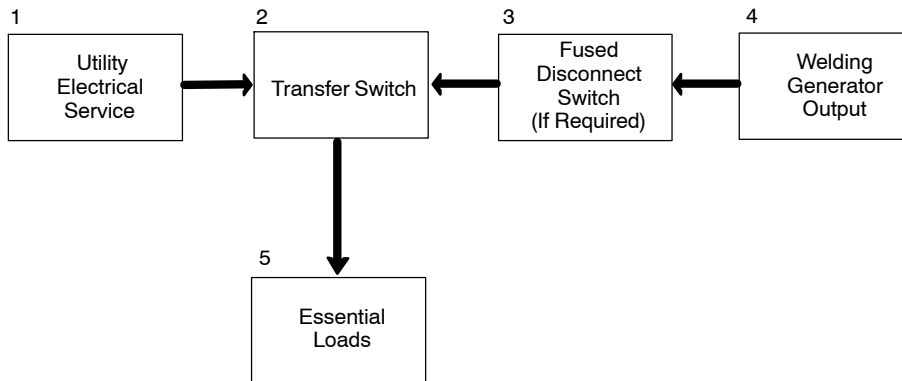

⚠ Have only qualified persons perform these connections according to all applicable codes and safety practices.

⚠ Properly install, ground, and operate this equipment according to its Owner's Manual and national, state, and local codes.

ⓘ *Customer-supplied equipment is required if generator will supply standby power during emergencies or power outages.*

1 Utility Electrical Service

2 Transfer Switch (Double-Throw)

Switch transfers the electrical load from electric utility service to the generator. Transfer load back to electric utility when service is restored.

Install correct switch (customer-supplied). Switch rating must be same as or greater than the branch overcurrent protection.

3 Fused Disconnect Switch

Install correct switch (customer-supplied) if required by electrical code.

4 Welding Generator Output

Generator output voltage and wiring must be consistent with regular (utility) system voltage and wiring.

Connect generator with temporary or permanent wiring suitable for the installation.

Turn off or unplug all equipment connected to generator before starting or stopping engine. When starting or stopping, the engine has low speed which causes low voltage and frequency.

5 Essential Loads

Generator output may not meet the electrical requirements of the premises. If generator does not produce enough output to meet all requirements, connect only essential loads (pumps, freezers, heaters, etc. – See Section 11-4).

11-11. Selecting Extension Cord (Use Shortest Cord Possible)

Cord Lengths for 120 Volt Loads							
							
⚠ Use GFCI protection when operating auxiliary equipment. If unit does not have GFCI receptacles, use GFCI-protected extension cord.							
Current (Amperes)	Load (Watts)	Maximum Allowable Cord Length in ft (m) for Conductor Size (AWG)*					
		4	6	8	10	12	14
5	600			350 (106)	225 (68)	137 (42)	100 (30)
7	840		400 (122)	250 (76)	150 (46)	100 (30)	62 (19)
10	1200	400 (122)	275 (84)	175 (53)	112 (34)	62 (19)	50 (15)
15	1800	300 (91)	175 (53)	112 (34)	75 (23)	37 (11)	30 (9)
20	2400	225 (68)	137 (42)	87 (26)	50 (15)	30 (9)	
25	3000	175 (53)	112 (34)	62 (19)	37 (11)		
30	3600	150 (46)	87 (26)	50 (15)	37 (11)		
35	4200	125 (38)	75 (23)	50 (15)			
40	4800	112 (34)	62 (19)	37 (11)			
45	5400	100 (30)	62 (19)				
50	6000	87 (26)	50 (15)				

*Conductor size is based on maximum 2% voltage drop

Cord Lengths for 240 Volt Loads							
							
⚠ Use GFCI protection when operating auxiliary equipment. If unit does not have GFCI receptacles, use GFCI-protected extension cord.							
Current (Amperes)	Load (Watts)	Maximum Allowable Cord Length in ft (m) for Conductor Size (AWG)*					
		4	6	8	10	12	14
5	1200			700 (213)	450 (137)	225 (68)	200 (61)
7	1680		800 (244)	500 (152)	300 (91)	200 (61)	125 (38)
10	2400	800 (244)	550 (168)	350 (107)	225 (69)	125 (38)	100 (31)
15	3600	600 (183)	350 (107)	225 (69)	150 (46)	75 (23)	60 (18)
20	4800	450 (137)	275 (84)	175 (53)	100 (31)	60 (18)	
25	6000	350 (107)	225 (69)	125 (38)	75 (23)		
30	7000	300 (91)	175 (53)	100 (31)	75 (23)		
35	8400	250 (76)	150 (46)	100 (31)			
40	9600	225 (69)	125 (38)	75 (23)			
45	10,800	200 (61)	125 (38)				
50	12,000	175 (53)	100 (31)				

*Conductor size is based on maximum 2% voltage drop

SECTION 12 – PARTS LIST

 Hardware is common and not available unless listed.

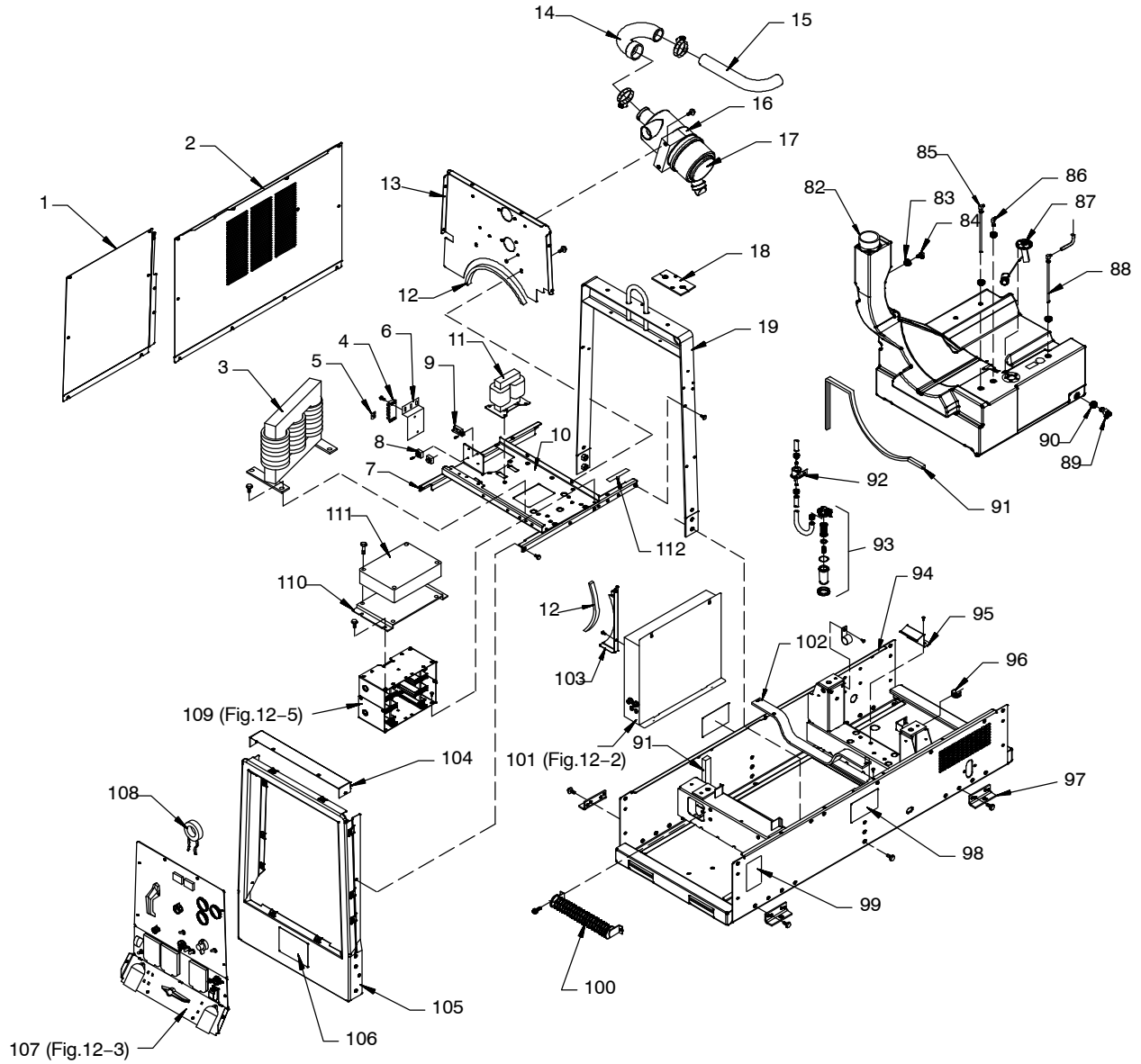
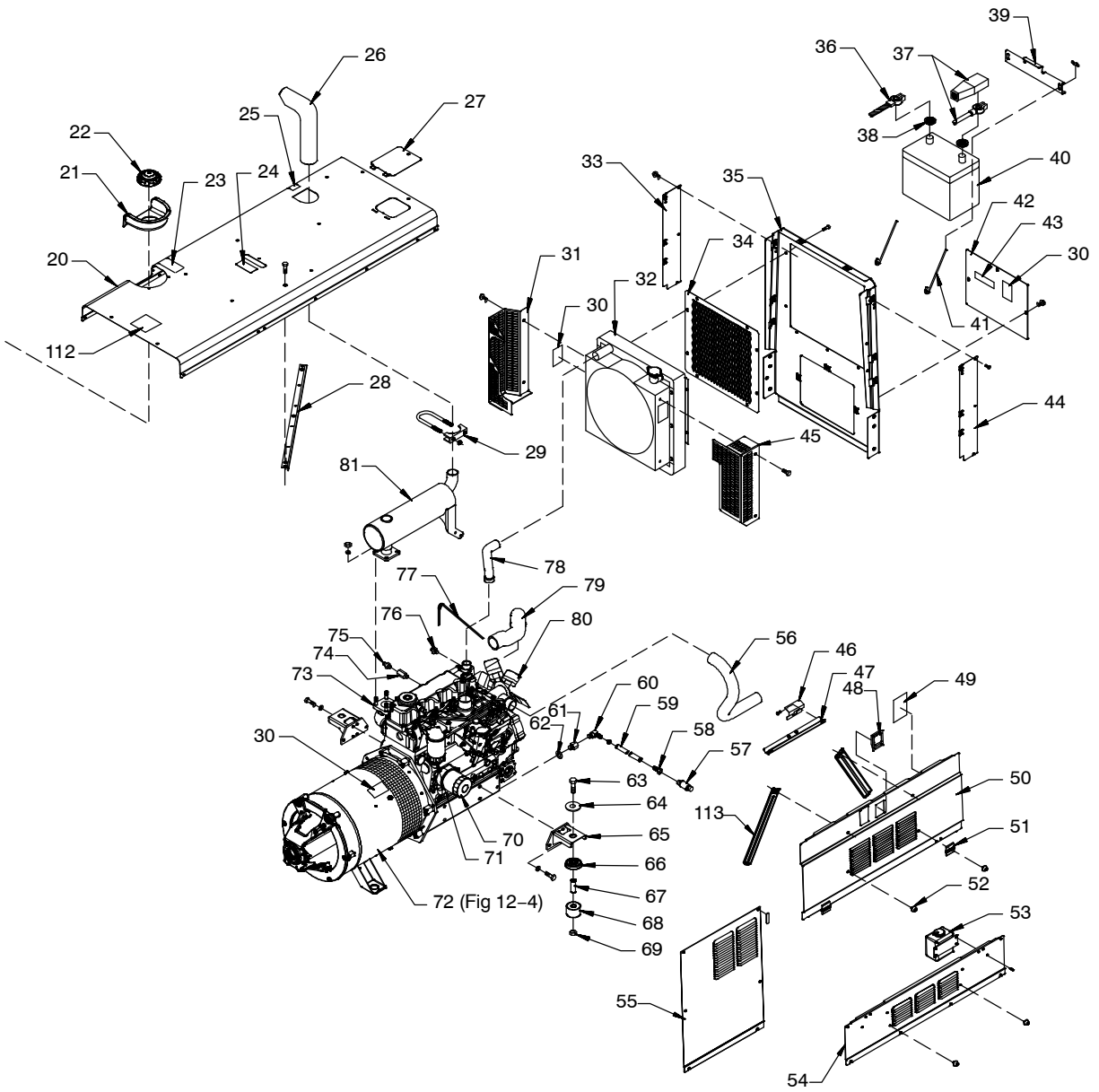

Figure 12-1. Main Assembly



Item No.	Dia. Mkgs.	Part No.	Description	Quantity
Figure 12-1. Main Assembly				
...	1	+199294 .. Panel, Gen Lh Stainless	1
...	2	+199301 .. Panel, Engine Side Stainless Stl	1
...	3	Z1 202647 .. Reactor, AC Environmental	1
...	4	1T 038621 .. Block, Term 30 Amp 4 Pole Frict Term Str Both Side	1
...	5	038620 .. Link, Jumper Term Blk 30 Amp	1
...	6	081499 .. Bracket, Mtg Terminal Strip	1
...	7	206352 .. Brace, Front To Center Upright	2
...	8	..	SR4, SR5 .. 035704 .. Rectifier, Integ Bridge 40 Amp 800v	2
...	9	CB4 045061 .. Circuit Breaker, Auto Reset 24vdc 7 Amp	1
...	10	201697 .. Pan, Reactor & rectifier	1
...	11	T1 205636 .. Transformer, W/Brkt Environmental	1
...	12	173352 .. Extrusion, Rubber Clamp/Bulb	2.75 ft
...	13	189708 .. Firewall, Top	1
...	14	206697 .. Hose, Elbow Air Cleaner	1
...	15	206393 .. Pipe, Air Cleaner Intake Kubota V3300	1
...	16	189763 .. Bracket, Mtg Air Cleaner	1
...	17	189764 .. Air Cleaner, Intake (consisting of)	1
.....		192938 .. Filter, Air Element Primary	1
.....		◆192939 .. Filter, Air Element Safety	1
...	18	189464 .. Seal, Weather Lift Eye	1
...	19	206351 .. Upright, Center Assy	1
...	20	+206541 .. Cover, Top Stainless Steel	1
...	21	189052 .. Grommet, Plastic Neck Filler Fuel	1
...	22	190198 .. Cap, Tank Screw-on 3.500 In W/Vent W/Lanyard (included w/tank)	1
...	23	192041 .. Label, Use Diesel Fuel Only	1
...	24	222513 .. Label, Warning Falling Equipment Can Cause Serious	1
...	25	224265 .. Label, Warning Hot Exhaust Parts Do Not Touch	1
...	26	105734 .. Pipe, Muffler Extension Elbow 1.750 Od	1
...	27	202629 .. Cover, Radiator Access Stainless	1
...	28	202633 .. Support, Cover E-Coat	1
...	29	010875 .. Clamp, Muffler 2.000 Dia U Pld	1
...	30	225120 .. Label, Warning Moving Parts Can Cause Injury	6
...	31	210725 .. Guard, Fan (Left)	1
...	32	206517 .. Radiator, W/Shroud & 7# Cap 4row Core Assy Rda (consisting of)	1
.....		206518 .. Radiator, Big Blue Air Pak	1
.....		605982 .. Cap, Radiator Pressure 7 Lb	1
.....		206384 .. Shroud, Radiator Kubota	1
...	33	207192 .. Panel, Engine Extension L.h. Stainless	1
...	34	Included in item 35	
...	35	201749 .. Upright, Rear Radiator	1
...	36	190206 .. Cable, Bat Neg 42 In Lg 2 Awg W/Clamp & .375 Rng	1
...	37	190207 .. Cable, Bat Pos 45 In Lg No 1 Awg W/Clamp & .406 Rng	1
...	38	108081 .. Terminal Protector, Battery Post Mtg	2
...	39	203430 .. Bracket, Battery Holddown	1
...	40	BATT 190896 .. Battery, Stor 12v 650 Crk 110 Rsv Gp 24 Low Mainte (Dry)	1
...	41	201006 .. Bolt, J Stl .312-18 X 7.750 Pld	2
...	42	+201183 .. Cover, Battery Access	1
...	43	168385 .. Label, Warning Battery Explosion Can Blind	1
...	44	207193 .. Panel, Engine Extension R.h. Stainless	1
...	45	206387 .. Guard, Fan (Right)	1
...	46	190992 .. Keeper, Latch Engine Access Door	1
...	47	206604 .. Channel, Stiffener Engine Access	1
...	48	190126 .. Latch, Paddle Series 20 Stainless	1
...	49	206999 .. Label, Maintenance D502K 5+4 Kubota	1
...	50	210736 .. Door, Engine Access Stainless	1

Item No.	Dia. Mkgs.	Part No.	Description	Quantity
Figure 12-1. Main Assembly (Continued)				
51		189975	Hinge, Door Access 180 Deg.	2
52		208141	Bumper, Door	4
53		190190	Tank, Coolant Recovery	1
54		199298	Panel, Rocker Stainless	1
		191626	Bumper, Door Engine Access	2
55		199300	Panel, Gen Rh Stainless	1
56		206391	Hose, Radiator Lower	1
		199507	Hose Assy, Oil Drain 20"lg (consisting of)	1
57		165271	Valve, Oil Drain 3/8-18 Nptf	1
58		176529	Ftg, Hose Brs Barbed Fem 1/2 Tbg X 3/8 Npt	1
59		113854	Hose, Sae .500 Id X .780 Od Xcoil	1.666
60		176528	Ftg, Hose Brs Barbed Elbow M 1/2 Tbg X 1/2 Npt	1
61		206906	Adapter, Oil Drain Fitting	1
62			Washer, Oil Drain (Available Through Engine Manufacturer)	1
63		199849	Screw, 625-11x4.00 Hex Hd-pln Gr5 Pld	4
64		071731	Washer, Flat .656idx2.250odx.187t Stl Pld	4
65		206396	Bracket, Mtg Engine Kubota V3300	2
66		071890	Retainer, Mount Eng/Gen	4
67		071730	Tubing, Stl .875 Od X12ga Wall X 2.500	4
68		083476	Mount, Eng/Gen Nprn .875id X 2.500od X 2.000 60 Dur	4
69		135205	Nut, 625-11 .94hex .77h Stl Pld Elastic Stop Nut	4
70		*207717	Filter, Oil (Spin-On Cartridge Type)	1
71		*207715	Filter, Fuel Secondary (Spin-on, Cartridge Type)	1
72		Figure 12-5	Generator	1
73		239361	Engine, Kubota Dsl Elec V3300 (Consisting Of)	1
		206380	Adapter, Engine Kubota V3300 (See Figure 12-5)	1
		206907	Plug Assy, W/Leads Elec Kubota	1
		*207713	Thermostat, 170f (76.5c) W/Gasket	1
		206379	Flywheel, Kubota V3300	1
74		198990	Adapter, Oil Pressure Sender	1
75	S12	187542	Switch, Pressure Oil 11psi No Cont Frict Term	1
76	TEMP SNDR	193231	Sender, Coolant Temp 300 Deg F 1/2-14 Npt	1
77		*207712	Belt, Fan 13 X 1200mm V-belt	1
78		206390	Hose, Radiator Upper	1
79		206392	Hose, Air Cleaner Intake Kubota V3300	1
80		207719	Fan, Engine Cooling 430mm, 6 Blade Pusher	1
81		206383	Manifold, Exhaust Muffler Kubota V3300	1
		207722	Gasket, Exhaust Manifold Metal	1
82		218087	Tank, Fuel (includes fuel cap) (consisting of)	1
83		124253	Bushing, Tank Fuel	4
84		189912	Ftg, Stl Barbed Elbow W/.047in Orifice Zinc Pld	1
85		189909	Ftg, Stand Pipe Hose .250 X 9.265lg 90 Deg Zinc	1
86		189913	Ftg, Stl Barbed Elbow Zinc Pld	1
87		190142	Sender, Fuel Gauge 9.750 Deep Tank	1
88		189910	Ftg, Stand Pipe Hose .3125 X 9.260lg 90 Deg Zinc	1
89		189908	Valve, Drain Fuel 180 Deg Zinc Pld	1
90		181572	Bushing, Tank Fuel	1
		107816	Hose, Sae .250 Id X .500 Od Xcoil	4.1 ft
91		191446	Extrusion, Rubber W/Adhesive 1.000 X 1.000 "d"	4.6 ft
92	FUEL PUMP	207721	Pump, Fuel Electric 12vdc 1.5a 400 Cc/Min 5psi	1
93		*233482	Kit, Fuel Sedimenter	1
		234714	Bracket, Sedimenter	1
94		+206350	Base	1
95		196220	Bracket, Holddown Fuel Tank Rear	1
96		192362	Bracket, Mtg Nyl 1/2 Conduit	1
97		191897	Bracket, Mtg Unit	4
98		224266	Label, Warning Do Not Weld On Base	2

Item No.	Dia. Mkgs.	Part No.	Description	Quantity
----------	------------	----------	-------------	----------

Figure 12-1. Main Assembly (Continued)

.. 99		246420	.. Label, Manufacturing Rating D550K HO Kubota	1
.. 100	R3	189699	.. Resistor, WW Tap 375 W 10 Ohm W/Mtg Bkt	1
.. 101	Figure 12-2		.. Control Box	1
.. 102		218086	.. Bracket, Holddown Fuel Tank	1
.. 103		189731	.. Firewall, Bottom	1
.. 104		191448	.. Cover, Top Front Upright	1
.. 105		201750	.. Upright, Front	1
.. 106		233953	.. Label, Warning General Precautionary CSA	1
.. 107	Figure 12-3		.. Panel, Front w/Components	1
.. 108		◆	.. Transformer, Current	1
.. 109	SR3 Figure 12-6		.. Main Rectifier Assembly	1
.. 110		193453	.. Bracket, Mtg Box Fcr	1
.. 111	PC1	207397	.. Module, Field Current Regulator	1
.. 112		203260	.. Label, Caution Do Not Use Ether	1
.. 113		210726	.. Stiffener, engine access door	2
.. 114		233088	.. Label, Danger Using A Generator Indoors Can Kill You In Minutes (Unit)	1
		237278	.. Label, Hour/Fuel Meter Usage	1
		191819	.. Hose, Sae .312 Id X .560 Od X 14.000	1
		095636	.. Hose, Sae .187 Id X .410 Od X 30.000	1
		198584	.. Hose, Sae .312 Id X .560 Od X 4.500	1
		049525	.. Nut, 312-18 U-nut Multi-thread	10
		190058	.. Nut, 250-20 U-nut Multi-thread	2
		210738	.. Kit, Label (Includes safety and informational labels)	1

+ When ordering a component originally displaying a precautionary label, the label should also be ordered. Order label individually or as part of label kit 210 738.

*Recommended Spare Parts. ◆Optional

To maintain the factory original performance of your equipment, use only Manufacturer's Suggested Replacement Parts. Model and serial number required when ordering parts from your local distributor.

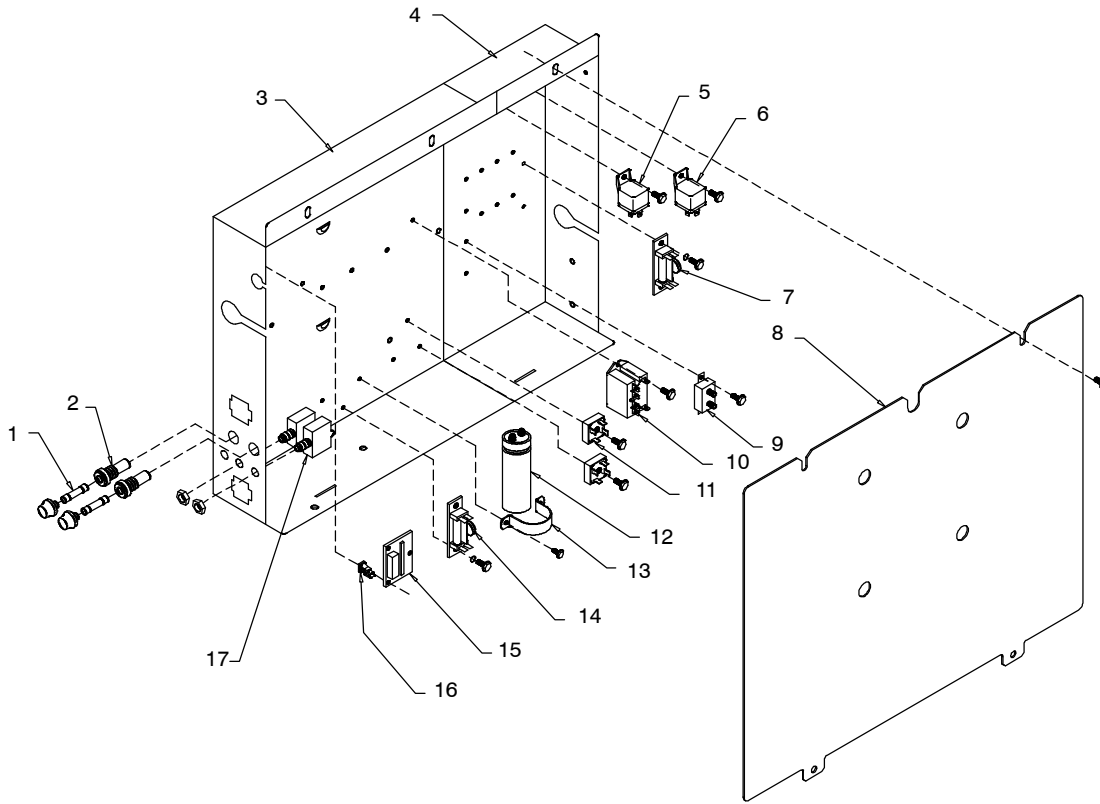

803 203-D

Figure 12-2. Control Box Assembly

Item No.	Dia. Mkgs.	Part No.	Description	Quantity
Figure 12-2. Control Box Assembly (Figure 12-1 Item 101)				
...	1 ... F1, F2 ..	*085874 ..	Fuse, Mintr Cer Slo-blo 10. Amp 250 Volt	2
...	2	046432 ..	Holder, Fuse Mintr .250 X 1.250 Panel Mtg	2
...	3	201077 ...	Control Box, Lh	1
...	4	201078 ..	Control Box, Rh	1
...	5 CR1	090104 ..	Relay, Encl 12vdc Spst 30a/15vdc 5pin Flange Mtg	1
...	6 CR2	173069 ..	Relay, Encl 12vdc Spdt 30a/20a 5pin Flange Mtg	1
...	7 .. D14/C14 ..	189701 ..	Diode/Capacitor Board	1
...	8	201079 ..	Cover, Control Box	1
...	9 CB10	190374 ..	Circuit Breaker, Auto Reset 12vdc 40 Amp	1
...	10 CR5	223710 ..	Relay, Encl 12vdc Dpst-no 25a 6pin Flange	1
...	11 .. SR1, SR2 ..	035704 ..	Rectifier, Integ Bridge 40. Amp 800v	2
...	12 C9	087110 ..	Capacitor, Elclt 240 Uf 200 Vdc Can 1.39 Di	1
...	13	177136 ..	Clamp, Capacitor 1.375 Dia	1
...	14 ... D1/C1 ..	189701 ..	Diode/Capacitor Board	1
...	15 PC9	192224 ..	Circuit Card Assy, Display	1
...	16	134201 ..	Stand-off Support, Pc Card .312/.375w/Post&lock .43	3
...	17 .. CB11, CB12 ..	139266 ..	Supplementary Protector, Man Reset 1p 15a 250vac	2
...	...	219873 ..	Harness, Control Box,Weld Control L.h. (consisting of)	1
...	...	RC3 158466	Conn, Rect Univ 084 12p/S 3row Rcpt Cable/Panel Lkg	1
...	...	RC1 135133	Conn, Rect Univ 084 9p/S 3row Rcpt Cable/Panel Lkg	1
...	...	221450 ..	Harness, Engine Kubota V3300 (consisting of)	1
...	...	S7 199691	Switch, Tgl Spdt 6a 125vac On-none-mc Spd Term (located on front panel, see Figure 12-3)	1
...	...	PLG10 ... 150316	Conn, Rect Univ 039 6p/S 3row Plug Cable Lkg	2

*Recommended Spare Parts.

To maintain the factory original performance of your equipment, use only Manufacturer's Suggested Replacement Parts. Model and serial number required when ordering parts from your local distributor.

☞ Hardware is common and not available unless listed.

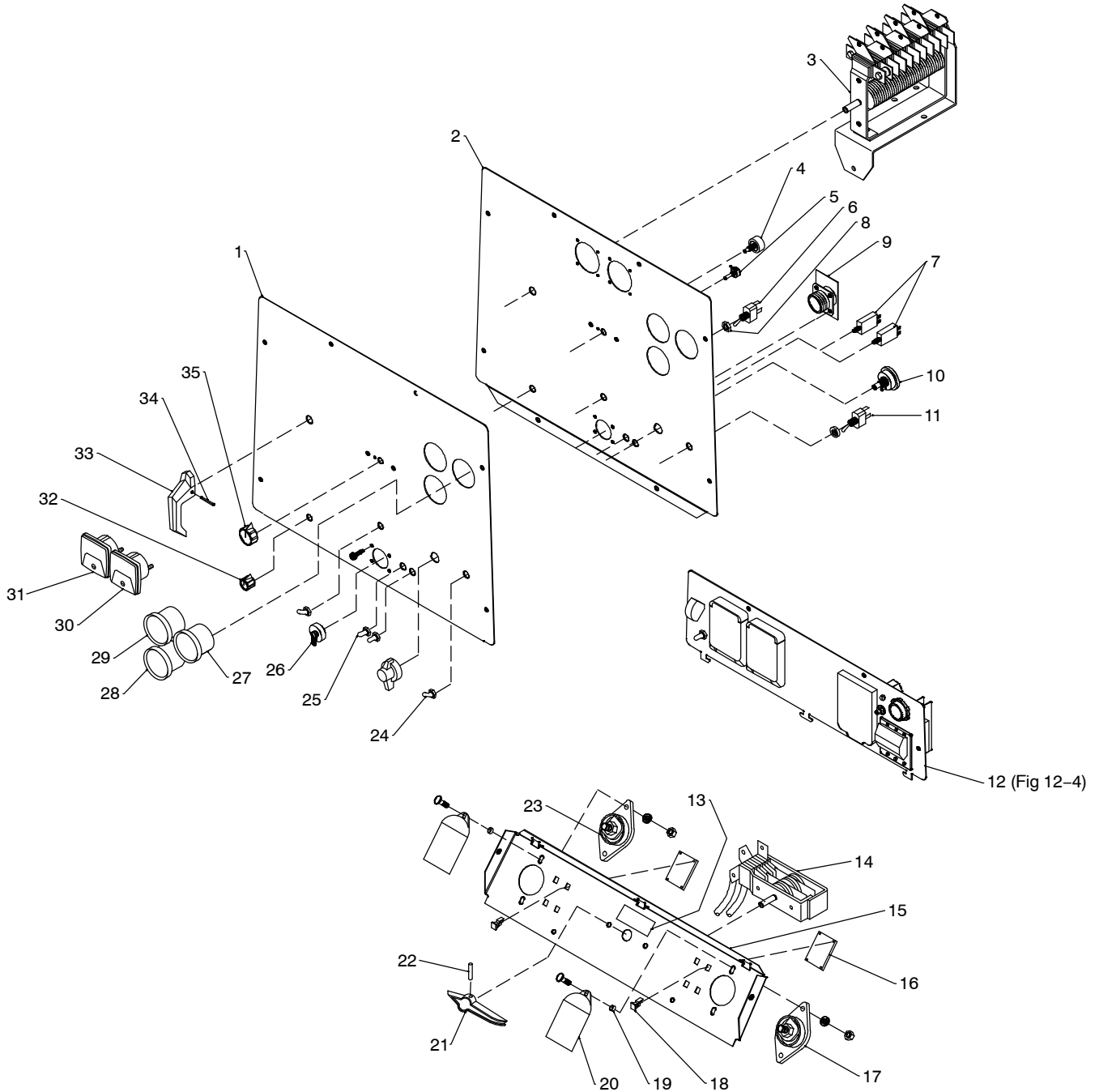

Figure 12-3. Panel, Front w/Components

804 700-B

Item No.	Dia. Mkgs.	Part No.	Description	Quantity
----------	------------	----------	-------------	----------

Figure 12-3. Panel, Front w/Components (Figure 12-1 Item 107)

...	1		Plate, Screened Ident Control (Order By Model And Serial Number)	...	1
...	2	236609	Panel, Engine/Weld Control Stainless	1
...	3	S3 208278	Switch, Range/Changeover	1
.....		192558	Harness, Range Switch (consisting of)	1
.....		RC6 148389	Conn,Rect Univ 084 4p/S 1row Rcpt Cable/Panel Lkg	1
...	4	R1 193118	Pot, Cp Flat 1t 2. W 1k Ohm Linear	1
.....		206809	Harness, Weld Control (consisting of)	1
...	5	S6 193234	Switch, Rotary 6 Position Gold Contacts	1
.....		197527	Guard, Circuit Breaker (For S6 – Not Included w/Harness)	1

Item No.	Dia. Mkgs.	Part No.	Description	Quantity
Figure 12-3. Panel, Front w/Components (Continued)				
6	S5	011609	Switch, Tgl Spdt 15a 125vac On–none–on Spd Term Chr	1
	PLG9	193183	Conn, Rect Cinch 18 Pin	1
		196603	Seal, Switch 6 Position Rotary .250 Shaft	1
	PLG14	141450	Conn, Rect Metrmate 10skt 1row Plug Cable Lkg	1
		164617	Clip, Wiring Straight	2
	RC10	150316	Conn, Rect Univ 039 6p/S 3row Plug Cable Lkg	1
7	CB5	139266	Supplementary Protector, Man Reset 1p 15a 250vac	1
	CB13	139266	Supplementary Protector, Man Reset 1p 15a 250vac	1
8		202209	Spacer, Nylon	2
9	PC6	192995	Circuit Card Assy, Connector/Receptacle	1
10	S1	207720	Switch, Ignition 3 Position (Mom–off–mom) W/Handle	1
11	S7	199691	Switch, Tgl Spdt 6a 125vac On–none–mc Spd Term (included in engine harness, see Figure 12-2)	1
12		Figure 12-4	Auxiliary Power Panel, High KVA	1
13		◆196073	Label, Do Not Switch While Welding	1
14		◆220491	Switch, Polarity/AC	1
14		◆195825	Switch, Polarity	1
15		201125	Panel, Mtg Terminal Power Output	1
16	PC4, PC5	189744	Circuit Card Assy, Filter Hf	2
17	NEGATIVE	241433	Terminal, Pwr Output Black	1
18		134201	Stand–off Support, Pc Card .312/.375w/Post&lock .43	8
19		181169	Spacer, Output Stud	2
20		186621	Boot, Generic Output Stud	2
21		◆059777	Handle, Switch	1
22		◆010647	Pin, Spring cs .156 x 1.250	1
23	POSITIVE	241432	Terminal, Pwr Output Red	1
24		021385	Boot, Toggle Switch Lever	2
25		190323	Boot, Circuit Breaker Clear Hex Nut	3
26		170391	Conn, Circ Ms Protective Cap Size 20 Nylon	1
27	FUEL/HM	233095	Gauge, Fuel Elec/Hour Meter	1
28	AM	118060	Meter, Amp Dc 60–0–60 2.250 Dia High Profile Stainl	1
29	TEMP	193229	Gauge, Coolant Temp 0– 300 Deg F Electric Switch	1
30		◆164873	Meter, Weld Amps	1
31		◆164874	Meter, Weld Volts	1
32		097922	Knob, Pointer .875 Dia X .250 Id W/Set Screwsplstc	1
33		189161	Handle, Switch Range	1
34		010647	Pin, Spring Cs .156 X 1.250	1
35		097924	Knob, Pointer 1.625 Dia X .250 Id W/Set Screwsplstc	1
		215207	Harness, Unit Weld Control – CV (consisting of)	1
	PLG6	114063	Conn, Rect Univ 084 4p/S 1row Plug Cable Lkg	1
	PLG8	193184	Conn, Rect Cinch 30 Pin	1
	PLG13	147992	Conn, Rect Univ 039 10p/S 2row Plug Cable Lkg	1
	PLG3	158465	Conn, Rect Univ 084 12p/S 3row Plug Cable Lkg	1
		088731	Bushing, Snap–in Nyl .375 Id X .500 Mtg Hole	1
		135873	Clip, Conduit Convolute 1/2 In 6.35mm Mtg Hole	3
		187654	Seal, Wire Univ 12p/S 3row	1
		196602	Plug, Cavity 18, 30 Position Cinch Connector	7
		024103	Blank, Snap–in Nyl .750 Mtg Hole Black	1
		120304	Blank, Snap–in Nyl .250 Mtg Hole Black	2

◆Optional

+ When ordering a component originally displaying a precautionary label, the label should also be ordered. Order label individually or as part of label kit 210 738.

To maintain the factory original performance of your equipment, use only Manufacturer's Suggested Replacement Parts. Model and serial number required when ordering parts from your local distributor.

☞ Hardware is common and not available unless listed.

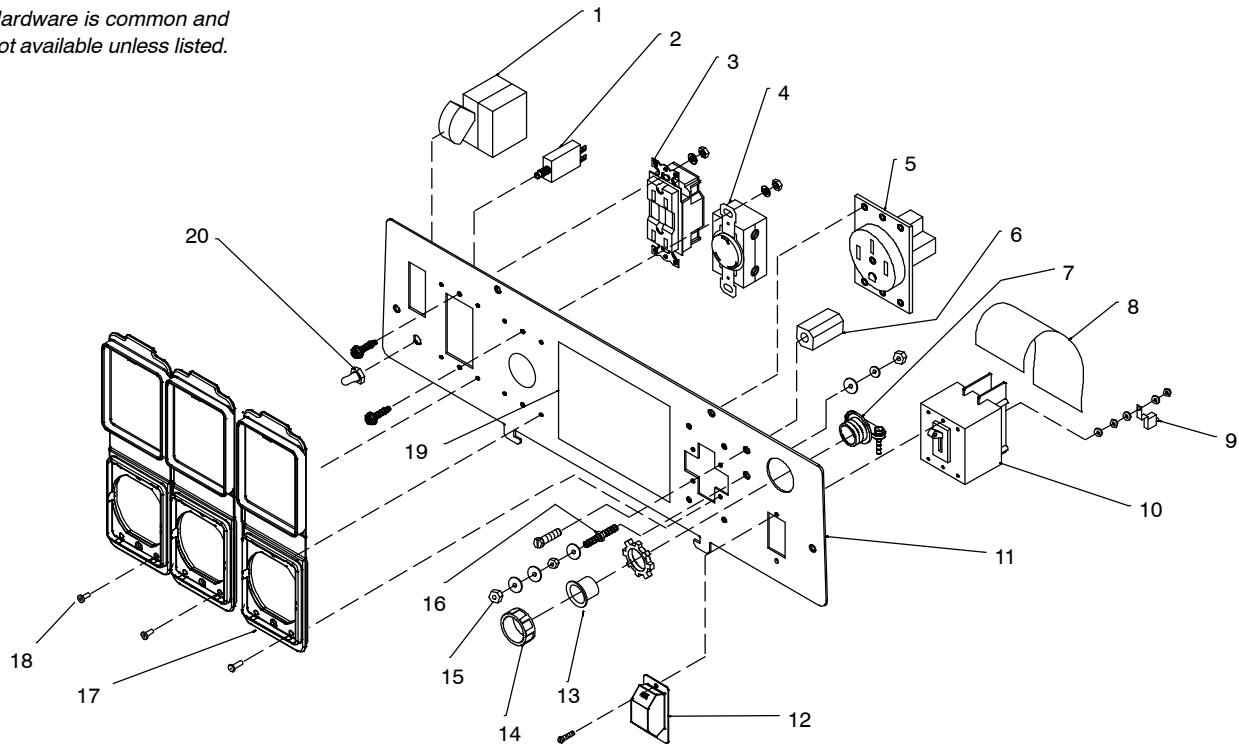

Figure 12-4. Auxiliary Power Panel, High KVA

Item No.	Dia. Mkgs.	Part No.	Description	Quantity
----------	------------	----------	-------------	----------

Figure 12-4. Auxiliary Power Panel, High KVA (Figure 12-3 Item 12)

...	1	CB1	201083	Supplementary Protector, Man Reset 2p 20a 250vac	1
.....			201553	Clip, Retaining Circuit Breaker	1
.....			201109	Harness, Receptacle Auxillary Power (consisting of)	1
...	2	CB2	093996	Supplementary Pro, Man Reset 1p 20a 250vac Frict	1
...	3	GFCI-1	246865	Rcpt, Str Dx Grd 2p3w 20a 125v *5-20r Gfi	1
...	4	RC1	147632	Rcpt, Tw Lk Grd 2p3w 30a 250v *L6-30r	1
.....			010146	Clamp, Nyl .625 Clamp Dia X.500 Wide .203 Mtg Hole	2
...	5	RC5	182954	Rcpt,Str 3p4w 50a 125/250v Flush Mtg *14-50	1
...	6		025248	Stand-off,Insul .250-20 X 1.250 Lg X .437 Thd	1
...	7		604102	Conn,Clamp Cable 1.000	1
...	8		197527	Guard,Circuit Breaker	1
...	9		197363	Terminal, Ring Tng Screw Clamp 14ga-6ga	3
...	10	CB7	214926	Supplementary Protector, Man Reset 3p 50a 250vac	1
...	11		+215363	Panel,Aux Power W/High Kva	1
...	12		214927	Boot,Circuit Breaker 1 Pole	1
...	13		197508	Plug,Protective	1
...	14		077440	Bushing,Conduit 1 In	1
...	15		601836	Nut, 250-20 .50hex .19h Brs	3
...	16		083030	Stud,Brs .250-20 X 1.750 W/Hex Collar	1
...	17		209056	Cover,Receptacle W/Gasket	3
...	18		127011	Rivet,Al .187 Dia X .251-.375 Grip Blind Domed Hd	12
...	19		197399	Label, Warning 3Ph Generator Power	1
...	20		206795	Boot,Circuit Breaker Clear Hex Nut	1

+ When ordering a component originally displaying a precautionary label, the label should also be ordered. Order label individually or as part of label kit 210 738.

To maintain the factory original performance of your equipment, use only Manufacturer's Suggested Replacement Parts. Model and serial number required when ordering parts from your local distributor.

☞ Hardware is common and not available unless listed.

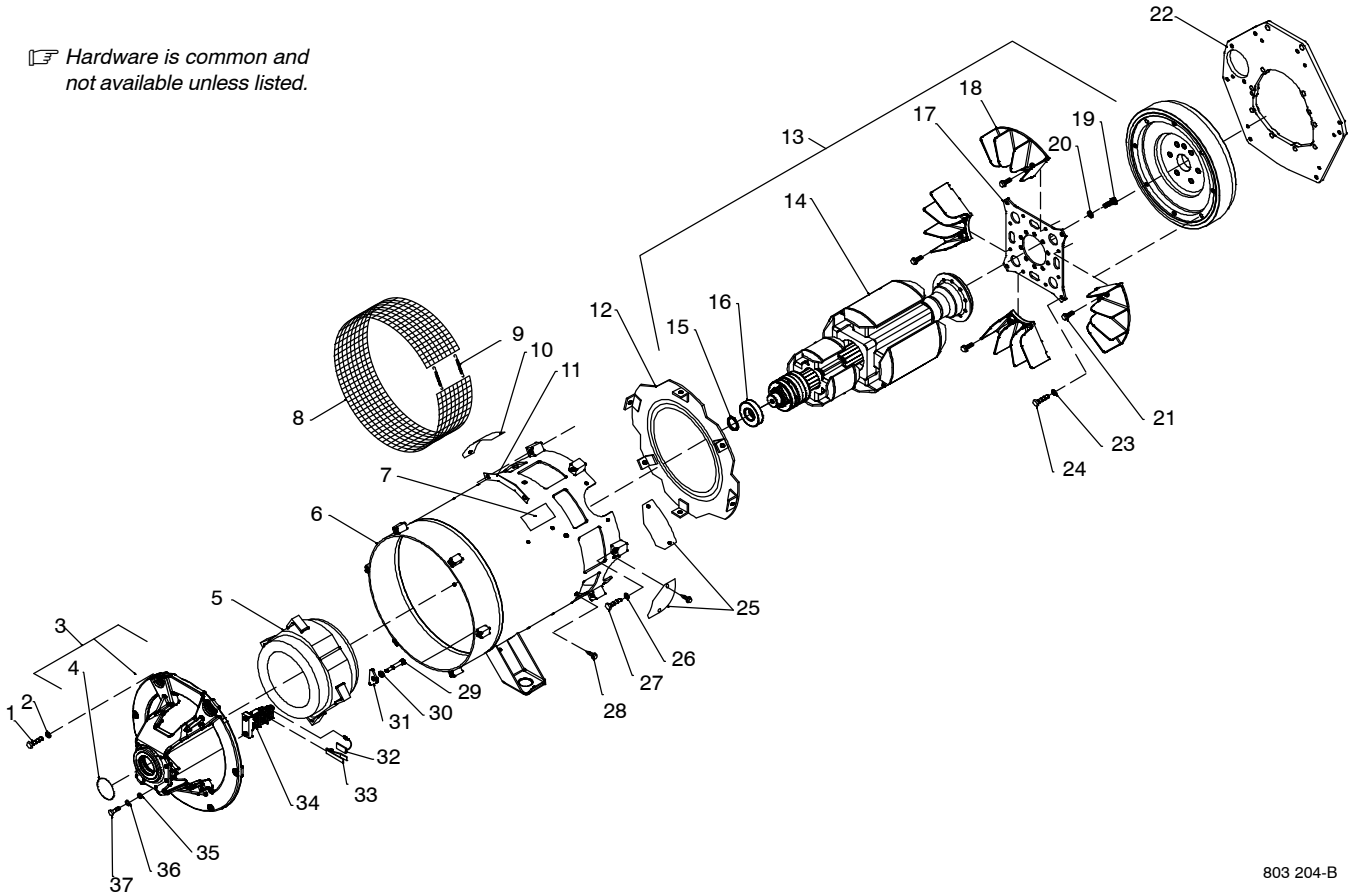

803 204-B

Figure 12-5. Generator

Item No.	Dia. Mkgs.	Part No.	Description	Quantity
----------	------------	----------	-------------	----------

Figure 12-5. Generator (Figure 12-1 Item 72)

...	1	132053	.. Screw, 375-16 X 1.50hexhd Pln Gr 5pld	6
...	2	183387	.. Washer, Conical Spring .406 Id X .875 Od Pltd	6
...	3	195911	.. Endbell, Gen (Consisting Of)	1
...	4	143220	.. O-ring, 2.859 Id X .139cs	1
...	5	AUX STATOR 214974	.. Stator, Weld/Power	1
...	6	WELD STATOR +254093	.. Stator, Weld Assembly Complete (High KVA)	1
...	7	225120	.. Label, Warning Moving Parts Can Cause Injury	2
...	8	190197	.. Guard, Generator Wire Mesh	1
...	9	172674	.. Spring, Ext .240 Od X .041 Wire X 3.500pld	2
...	10	191580	.. Cover, Starter Hole	1
...	11	208216	.. Spacer, Stl Kubota V3300 18ga Generator	1
...	12	039207	.. Baffle, Air	1
...	13	ROTOR 251855	.. Rotor, Generator Segmented Assy (Includes)	1
...	14	251856	.. Rotor, Generator (Includes)	1
...	15	024617	.. Ring, Rtnng Ext 1.375 Shaft X .050 Thk	1
...	16	053390	.. Bearing, Ball Rdl Sgl Row 1.370 X 2.830 X .6	1
...			.. Hub, Drive (Not Sold Separately)	1
...		210447	.. Fan, Rotor Assy Generator (Segmented) (includes)	1
...	17	210332	.. Plate, Flex Hubmount	1
...	18	206242	.. Fan, Rotor Segmented Assy Gen	4
...	19	049026	.. Screw, M10-1.5x 25 Hex Hd-pln 8.8 Pln	10
...	20	083883	.. Washer, Lock .402idx0.709odx.087t Stl Split10mm	10
...	21	080389	.. Screw, 312-18x1.00 Hexwhd.66d Stl Pld Stffmg Tap-rw	8
...	22	206380	.. Adapter, engine	1
...	23	083883	.. Washer, Lock .402idx0.709odx.087t Stl Split10mm	4
...	24	049026	.. Screw, M10-1.5x 25 Hex Hd-pln 8.8 Pln	4

Item No.	Dia. Mkgs.	Part No.	Description	Quantity
----------	------------	----------	-------------	----------

Figure 12-5. Generator (Continued)

... 25		191579	.. Cover, Starter Hole	2
... 26		083883	.. Washer, Lock .402idx0.709odx.087t Stl Split10mm	6
... 27		172555	.. Screw, M10-1.5 X 50hexhd Pln 8.8pld	6
... 28		602159	.. Screw, .312-18 X .75hexwhd	6
... 29		604950	.. Screw, .312-18 X 2.25hexhd Pln Gr 5pld	4
... 30		602211	.. Washer, Lock .318 ld X 0.586	4
... 31		139341	.. Washer, Exciter	4
... 32		*190823	.. Brush, Contact	3
... 33		208469	.. Clip, Spring	3
... 34		189142	.. Brushholder Assembly, Gen	1
... 35		602242	.. Washer, Flat .375idx0.875odx.083t Stl Pld	2
... 36		602211	.. Washer, Lock .318idx0.586odx.078t Stl Pld Split.312	2
... 37		604534	.. Screw, 312-18x1.25 Hex Hd-pln Gr5 Pld	2
		190259	.. Harness, Brush (Consisting Of)	1
	PLG1	168071 Connector, (Kit) Rect Univ 084 9p/S 3 Row Plug Cable Lkg	1
		187651 Seal, Wire Univ 9p/S 3 Row	1

+ When ordering a component originally displaying a precautionary label, the label should also be ordered. Order label individually or as part of label kit 210 738.

*Recommended Spare Parts.

◆Optional

To maintain the factory original performance of your equipment, use only Manufacturer's Suggested Replacement Parts. Model and serial number required when ordering parts from your local distributor.

☞ Hardware is common and not available unless listed.

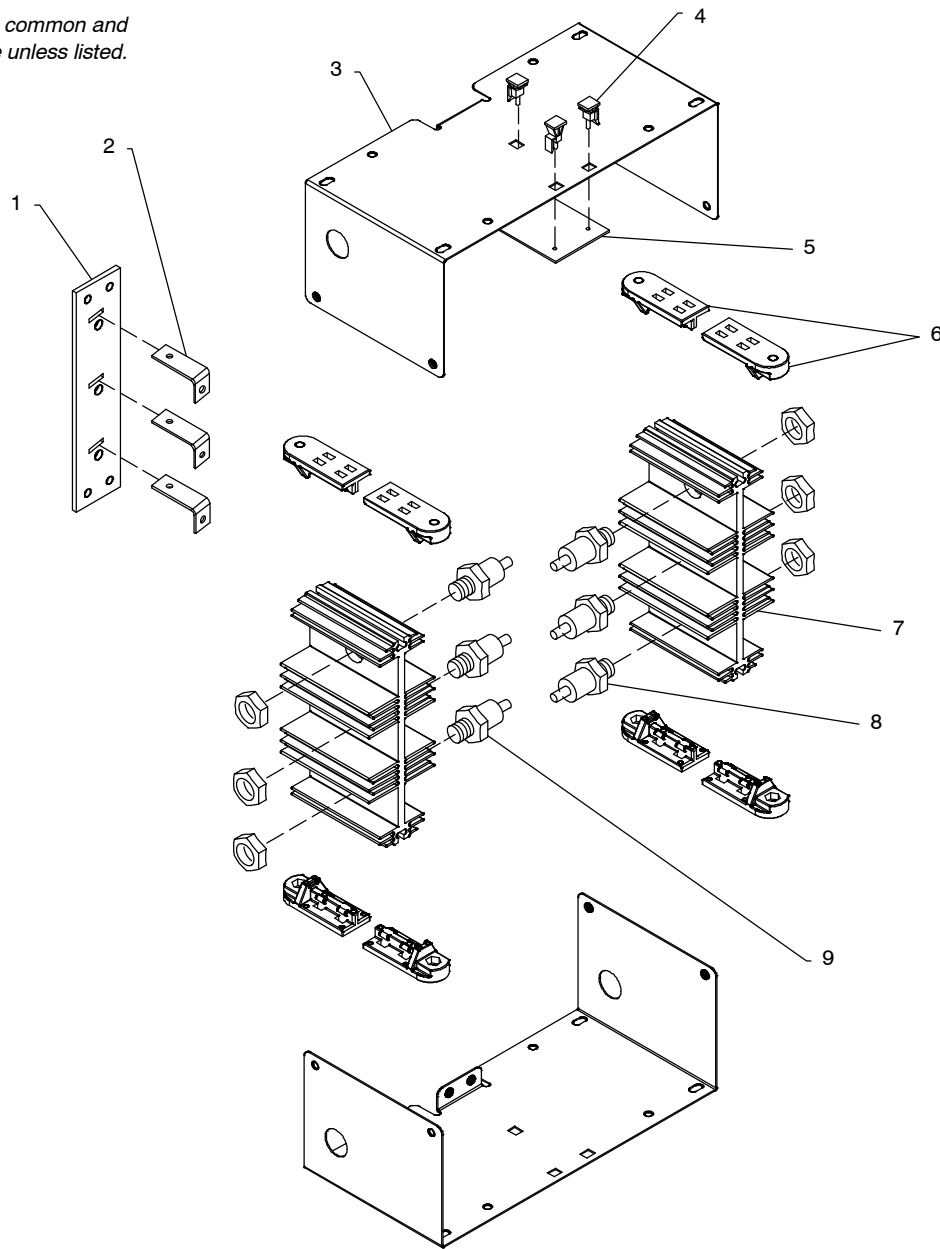

802 279-A

Figure 12-6. Main Rectifier Assembly

Item No.	Dia. Mkgs.	Part No.	Description	Quantity
----------	------------	----------	-------------	----------

Figure 12-6. Main Rectifier Assembly (Figure 12-1 Item 109)

.....	SR3 239784	.. Rectifier, Environmental High Power (Consisting Of) 1
... 1 188137 Connection Board, Rectifier Ac 1
... 2 188517 Bus Bar, Connection Board 3
... 3 188135 Enclosure, Rectifier 2
... 4 134201 Stand-off, Support 3
... 5	PC3 215755 Circuit Card Assembly, Protection 1
... 6 188136 Insulator, Heat Sink 8
... 7 188493 Heat Sink, Rectifier Al 2
... 8	D3, D5, D7	.. 245097 Diode, Rect 300 A 500v Do-9 (Straight) Modified 3
... 9	D2, D4, D6	.. 245096 Diode, Rect 300 A 500v Do-9 (Reversed) Modified 3

To maintain the factory original performance of your equipment, use only Manufacturer's Suggested Replacement Parts. Model and serial number required when ordering parts from your local distributor.
Base Group

Notes

DECIMAL EQUIVALENTS

	$\frac{1}{64}$.015625
	$\frac{2}{64}$.03125
	$\frac{3}{64}$.046875
	$\frac{4}{64}$.0625
	$\frac{5}{64}$.078125
	$\frac{6}{64}$.09375
	$\frac{7}{64}$.109375
	$\frac{8}{64}$.125
	$\frac{9}{64}$.140625
	$\frac{10}{64}$.15625
	$\frac{11}{64}$.171875
	$\frac{12}{64}$.1875
	$\frac{13}{64}$.203125
	$\frac{14}{64}$.21875
	$\frac{15}{64}$.234375
	$\frac{16}{64}$.25
	$\frac{17}{64}$.265625
	$\frac{18}{64}$.28125
	$\frac{19}{64}$.296875
	$\frac{20}{64}$.3125
	$\frac{21}{64}$.328125
	$\frac{22}{64}$.34375
	$\frac{23}{64}$.359375
	$\frac{24}{64}$.375
	$\frac{25}{64}$.390625
	$\frac{26}{64}$.40625
	$\frac{27}{64}$.421875
	$\frac{28}{64}$.4375
	$\frac{29}{64}$.453125
	$\frac{30}{64}$.46875
	$\frac{31}{64}$.484375
	$\frac{32}{64}$.5
	$\frac{33}{64}$.515625
	$\frac{34}{64}$.53125
	$\frac{35}{64}$.546875
	$\frac{36}{64}$.5625
	$\frac{37}{64}$.578125
	$\frac{38}{64}$.59375
	$\frac{39}{64}$.609375
	$\frac{40}{64}$.625
	$\frac{41}{64}$.640625
	$\frac{42}{64}$.65625
	$\frac{43}{64}$.671875
	$\frac{44}{64}$.6875
	$\frac{45}{64}$.703125
	$\frac{46}{64}$.71875
	$\frac{47}{64}$.734375
	$\frac{48}{64}$.75
	$\frac{49}{64}$.765625
	$\frac{50}{64}$.78125
	$\frac{51}{64}$.796875
	$\frac{52}{64}$.8125
	$\frac{53}{64}$.828125
	$\frac{54}{64}$.84375
	$\frac{55}{64}$.859375
	$\frac{56}{64}$.875
	$\frac{57}{64}$.890625
	$\frac{58}{64}$.90625
	$\frac{59}{64}$.921875
	$\frac{60}{64}$.9375
	$\frac{61}{64}$.953125
	$\frac{62}{64}$.96875
	$\frac{63}{64}$.984375
	1	1.

Warranty

Effective January 1, 2011
(Equipment with a serial number preface of MB or newer)

This limited warranty supersedes all previous manufacturers warranties and is exclusive with no other guarantees or warranties expressed or implied.

LIMITED WARRANTY – Subject to the terms and conditions below, warrants to its original retail purchaser that new equipment sold after the effective date of this limited warranty is free of defects in material and workmanship at the time it is shipped from factory. THIS WARRANTY IS EXPRESSLY IN LIEU OF ALL OTHER WARRANTIES, EXPRESS OR IMPLIED, INCLUDING THE WARRANTIES OF MERCHANTABILITY AND FITNESS.

Within the warranty periods listed below, manufacturer will repair or replace any warranted parts or components that fail due to such defects in material or workmanship. Manufacturer must be notified in writing within thirty (30) days of such defect or failure, at which time manufacturer will provide instructions on the warranty claim procedures to be followed.

Manufacturer shall honor warranty claims on warranted equipment listed below in the event of such a failure within the warranty time periods. All warranty time periods start on the delivery date of the equipment to the original end-user purchaser, and not to exceed one year after the equipment is shipped to the distributor.

1. 5 Years Parts — 3 Years Labor
 - * Original main power rectifiers only to include SCRs, diodes, and discrete rectifier modules
2. 3 Years — Parts and Labor
 - * Engine Driven Welding Generators
(NOTE: Engines are warranted separately by the engine manufacturer.)
 - * Inverter Power Sources (Unless Otherwise Stated)
 - * Plasma Arc Cutting Power Sources
 - * Process Controllers
 - * Semi-Automatic and Automatic Wire Feeders
 - * Smith 30 Series Flowgauge and Flowmeter Regulators (No Labor)
 - * Transformer/Rectifier Power Sources
 - * Water Coolant Systems (Integrated)
3. 2 Years — Parts
 - * Auto-Darkening Helmet Lenses (No Labor)
4. 1 Year — Parts and Labor Unless Specified
 - * Automatic Motion Devices
 - * CoolBelt and CoolBand Blower Unit (No Labor)
 - * External Monitoring Equipment and Sensors
 - * Field Options
(NOTE: Field options are covered for the remaining warranty period of the product they are installed in, or for a minimum of one year — whichever is greater.)
 - * Flowgauge and Flowmeter Regulators (No Labor)
 - * RFCS Foot Controls (Except RFCS-RJ45)
 - * Fume Extractors
 - * HF Units
 - * ICE Plasma Cutting Torches (No Labor)
 - * Induction Heating Power Sources, Coolers, and Electronic Controls/Recorders
 - * Load Banks
 - * Motor Driven Guns (w/exception of Spoolmate Spoolguns)
 - * PAPR Blower Unit (No Labor)
 - * Positioners and Controllers
 - * Racks
 - * Running Gear/Trailers
 - * Spot Welders
 - * Subarc Wire Drive Assemblies
 - * Water Coolant Systems (Non-Integrated)
 - * Weldcraft-Branded TIG Torches (No Labor)
 - * Wireless Remote Foot/Hand Controls and Receivers
 - * Work Stations/Weld Tables (No Labor)
5. 6 Months — Parts
 - * Batteries
 - * Bernard Guns (No Labor)
 - * Tregaskiss Guns (No Labor)

6. 90 Days — Parts
 - * Accessory (Kits)
 - * Canvas Covers
 - * Induction Heating Coils and Blankets, Cables, and Non-Electronic Controls
 - * M-Guns
 - * MIG Guns and Subarc (SAW) Guns
 - * Remote Controls and RFCS-RJ45
 - * Replacement Parts (No labor)
 - * Roughneck Guns
 - * Spoolmate Spoolguns

Limited Warranty shall not apply to:

1. **Consumable components; such as contact tips, cutting nozzles, contactors, brushes, relays, work station table tops and welding curtains, or parts that fail due to normal wear. (Exception: brushes and relays are covered on all engine-driven products.)**
2. Items furnished by manufacturer, but manufactured by others, such as engines or trade accessories. These items are covered by the manufacturer's warranty, if any.
3. Equipment that has been modified by any party other than manufacturer, or equipment that has been improperly installed, improperly operated or misused based upon industry standards, or equipment which has not had reasonable and necessary maintenance, or equipment which has been used for operation outside of the specifications for the equipment.

MANUFACTURER'S PRODUCTS ARE INTENDED FOR PURCHASE AND USE BY COMMERCIAL/INDUSTRIAL USERS AND PERSONS TRAINED AND EXPERIENCED IN THE USE AND MAINTENANCE OF WELDING EQUIPMENT.

In the event of a warranty claim covered by this warranty, the exclusive remedies shall be, at manufacturer's option: (1) repair; or (2) replacement; or, where authorized in writing by manufacturer in appropriate cases, (3) the reasonable cost of repair or replacement at an authorized service station; or (4) payment of or credit for the purchase price (less reasonable depreciation based upon actual use) upon return of the goods at customer's risk and expense. Manufacturer's option of repair or replacement will be F.O.B., Factory at Appleton, Wisconsin, or F.O.B. at an authorized service facility as determined by manufacturer. Therefore no compensation or reimbursement for transportation costs of any kind will be allowed.

TO THE EXTENT PERMITTED BY LAW, THE REMEDIES PROVIDED HEREIN ARE THE SOLE AND EXCLUSIVE REMEDIES. IN NO EVENT SHALL MANUFACTURER BE LIABLE FOR DIRECT, INDIRECT, SPECIAL, INCIDENTAL OR CONSEQUENTIAL DAMAGES (INCLUDING LOSS OF PROFIT), WHETHER BASED ON CONTRACT, TORT OR ANY OTHER LEGAL THEORY.

ANY EXPRESS WARRANTY NOT PROVIDED HEREIN AND ANY IMPLIED WARRANTY, GUARANTY OR REPRESENTATION AS TO PERFORMANCE, AND ANY REMEDY FOR BREACH OF CONTRACT TORT OR ANY OTHER LEGAL THEORY WHICH, BUT FOR THIS PROVISION, MIGHT ARISE BY IMPLICATION, OPERATION OF LAW, CUSTOM OF TRADE OR COURSE OF DEALING, INCLUDING ANY IMPLIED WARRANTY OF MERCHANTABILITY OR FITNESS FOR PARTICULAR PURPOSE, WITH RESPECT TO ANY AND ALL EQUIPMENT FURNISHED BY MANUFACTURER IS EXCLUDED AND DISCLAIMED BY MANUFACTURER.

Some states in the U.S.A. do not allow limitations of how long an implied warranty lasts, or the exclusion of incidental, indirect, special or consequential damages, so the above limitation or exclusion may not apply to you. This warranty provides specific legal rights, and other rights may be available, but may vary from state to state.

In Canada, legislation in some provinces provides for certain additional warranties or remedies other than as stated herein, and to the extent that they may not be waived, the limitations and exclusions set out above may not apply. This Limited Warranty provides specific legal rights, and other rights may be available, but may vary from province to province.



Owner's Record

Please complete and retain with your personal records.

Model Name

Serial/Style Number

Purchase Date

(Date which equipment was delivered to original customer.)

Distributor

Address

City

State

Zip

Red-D-Arc
Welderrentals

1-866-RED-D-ARC

reddarc.com

Contact the Delivering Carrier for:

File a claim for loss or damage during shipment.

For assistance in filing or settling claims, contact your distributor and/or equipment manufacturer's Transportation Department.
