

Processes



Multiprocess Welding

Description



Arc Welding Power Source

EXTREME 360 MAP

Auto-Line™

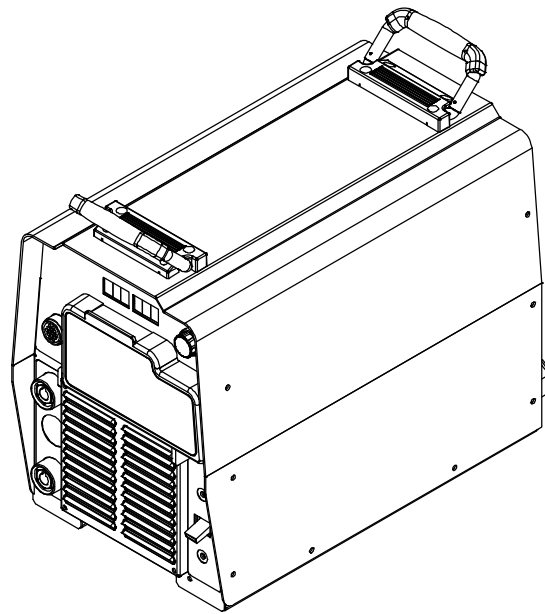

OWNER'S MANUAL



TABLE OF CONTENTS

SECTION 1 – SAFETY PRECAUTIONS - READ BEFORE USING	1
1-1. Symbol Usage	1
1-2. Arc Welding Hazards	1
1-3. Additional Symbols For Installation, Operation, And Maintenance	3
1-4. California Proposition 65 Warnings	4
1-5. Principal Safety Standards	4
1-6. EMF Information	4
SECTION 2 – CONSIGNES DE SÉCURITÉ – LIRE AVANT UTILISATION	5
2-1. Symboles utilisés	5
2-2. Dangers relatifs au soudage à l'arc	5
2-3. Dangers supplémentaires en relation avec l'installation, le fonctionnement et la maintenance	7
2-4. Proposition californienne 65 Avertissements	8
2-5. Principales normes de sécurité	8
2-6. Informations relatives aux CEM	8
SECTION 3 – DEFINITIONS	9
3-1. Manufacturer Safety Symbols And Definitions	9
3-2. Miscellaneous Symbols And Definitions	9
SECTION 4 – SPECIFICATIONS	10
4-1. Features And Benefits	10
4-2. Arc Controls	10
4-3. Serial Number And Rating Label Location	10
4-4. Unit Specifications	10
4-5. Dimensions And Weight	11
4-6. Duty Cycle And Overheating	12
4-7. Static Output Characteristics	12
SECTION 5 – INSTALLATION	13
5-1. Selecting A Location	13
5-2. Selecting Cable Sizes*	14
5-3. Weld Output Terminals	14
5-4. Remote 14 Receptacle Information	15
5-5. Optional 115 Volts AC Duplex Receptacle And Supplementary Protectors	15
5-6. Optional Gas Valve Operation And Shielding Gas Connection	16
5-7. Electrical Service Guide	17
5-8. Connecting 1-Phase Input Power	18
5-9. Connecting 3-Phase Input Power	20
SECTION 6 – GENERAL OPERATION	22
6-1. Front Panel	22
6-2. Mode Switch Settings	23
6-3. Configuration Option Menu	24
SECTION 7 – GTAW OPERATION	26
7-1. Typical Connection For GTAW Process	26
7-2. Scratch Start TIG Welding Mode - GTAW Process	27
7-3. Lift-Arc TIG Welding Mode - GTAW Process	28
7-4. TIG Welding Mode - GTAW Process	29
SECTION 8 – GMAW/GMAW-P/FCAW OPERATION	30
8-1. Typical Connection For Remote Control Feeder GMAW/GMAW-P/FCAW Process	30
8-2. MIG Welding Mode - GMAW/FCAW Process	32
8-3. MIG - Wire and Gas Selection Table	33
8-4. Pulsed MIG Welding Mode - GMAW-P Process	34

TABLE OF CONTENTS

SECTION 8 – GMAW/GMAW-P/FCAW OPERATION (Continued)	30
8-5. Pulsed MIG - Wire and Gas Selection Table	35
8-6. Remote Process Select	36
8-7. Typical Connection For Voltage-Sensing Feeder GMAW/GMAW-P/FCAW Process	37
8-8. V-Sense Feeder Welding Mode - GMAW/FCAW Process	38
8-9. V-Sense Feeder Welding Mode - GMAW-P Process	39
SECTION 9 – SMAW/CAC-A OPERATION	40
9-1. Typical Connection For SMAW And CAC-A Process	40
9-2. CC Welding Mode - SMAW/CAC-A Process	41
9-3. Stick Welding Mode - SMAW/CAC-A Process	42
9-4. Optional Low Open Circuit Voltage (OCV) Welding Modes	43
SECTION 10 – MAINTENANCE & TROUBLESHOOTING	44
10-1. Routine Maintenance	44
10-2. Blowing Out Inside Of Unit	44
10-3. Help Displays	45
10-4. Troubleshooting	46
SECTION 11 – ELECTRICAL DIAGRAM	48

WARRANTY

COMPLETE PARTS LIST – Available at www.MillerWelds.com

Red-D-Arc
Welderentals
1-866-RED-D-ARC reddarc.com

SECTION 1 – SAFETY PRECAUTIONS - READ BEFORE USING

som 2015-09

 Protect yourself and others from injury — read, follow, and save these important safety precautions and operating instructions.

1-1. Symbol Usage



DANGER! – Indicates a hazardous situation which, if not avoided, will result in death or serious injury. The possible hazards are shown in the adjoining symbols or explained in the text.



Indicates a hazardous situation which, if not avoided, could result in death or serious injury. The possible hazards are shown in the adjoining symbols or explained in the text.

NOTICE – Indicates statements not related to personal injury.

 Indicates special instructions.



This group of symbols means Warning! Watch Out! ELECTRIC SHOCK, MOVING PARTS, and HOT PARTS hazards. Consult symbols and related instructions below for necessary actions to avoid the hazards.

1-2. Arc Welding Hazards



The symbols shown below are used throughout this manual to call attention to and identify possible hazards. When you see the symbol, watch out, and follow the related instructions to avoid the hazard. The safety information given below is only a summary of the more complete safety information found in the Safety Standards listed in Section 1-5. Read and follow all Safety Standards.



Only qualified persons should install, operate, maintain, and repair this unit.



During operation, keep everybody, especially children, away.



ELECTRIC SHOCK can kill.

Touching live electrical parts can cause fatal shocks or severe burns. The electrode and work circuit is electrically live whenever the output is on. The input power circuit and machine internal circuits are also live when power is on. In semiautomatic or automatic wire welding, the wire, wire reel, drive roll housing, and all metal parts touching the welding wire are electrically live. Incorrectly installed or improperly grounded equipment is a hazard.

- Do not touch live electrical parts.

- Wear dry, hole-free insulating gloves and body protection.
- Insulate yourself from work and ground using dry insulating mats or covers big enough to prevent any physical contact with the work or ground.
- Do not use AC output in damp areas, if movement is confined, or if there is a danger of falling.
- Use AC output ONLY if required for the welding process.
- If AC output is required, use remote output control if present on unit.
- Additional safety precautions are required when any of the following electrically hazardous conditions are present: in damp locations or while wearing wet clothing; on metal structures such as floors, gratings, or scaffolds; when in cramped positions such as sitting, kneeling, or lying; or when there is a high risk of unavoidable or accidental contact with the workpiece or ground. For these conditions, use the following equipment in order presented: 1) a semiautomatic DC constant voltage (wire) welder, 2) a DC manual (stick) welder, or 3) an AC welder with reduced open-circuit voltage. In most situations, use of a DC, constant voltage wire welder is recommended. And, do not work alone!
- Disconnect input power or stop engine before installing or servicing this equipment. Lockout/tagout input power according to OSHA 29 CFR 1910.147 (see Safety Standards).
- Properly install, ground, and operate this equipment according to its Owner's Manual and national, state, and local codes.

- Always verify the supply ground – check and be sure that input power cord ground wire is properly connected to ground terminal in disconnect box or that cord plug is connected to a properly grounded receptacle outlet.
- When making input connections, attach proper grounding conductor first – double-check connections.
- Keep cords dry, free of oil and grease, and protected from hot metal and sparks.
- Frequently inspect input power cord and ground conductor for damage or bare wiring – replace immediately if damaged – bare wiring can kill.
- Turn off all equipment when not in use.
- Do not use worn, damaged, undersized, or repaired cables.
- Do not drape cables over your body.
- If earth grounding of the workpiece is required, ground it directly with a separate cable.
- Do not touch electrode if you are in contact with the work, ground, or another electrode from a different machine.
- Do not touch electrode holders connected to two welding machines at the same time since double open-circuit voltage will be present.
- Use only well-maintained equipment. Repair or replace damaged parts at once. Maintain unit according to manual.
- Wear a safety harness if working above floor level.
- Keep all panels and covers securely in place.
- Clamp work cable with good metal-to-metal contact to workpiece or worktable as near the weld as practical.
- Insulate work clamp when not connected to workpiece to prevent contact with any metal object.
- Do not connect more than one electrode or work cable to any single weld output terminal. Disconnect cable for process not in use.
- Use GFCI protection when operating auxiliary equipment in damp or wet locations.

SIGNIFICANT DC VOLTAGE exists in inverter welding power sources AFTER removal of input power.

- Turn Off inverter, disconnect input power, and discharge input capacitors according to instructions in Maintenance Section before touching any parts.



HOT PARTS can burn.

- Do not touch hot parts bare handed.
- Allow cooling period before working on equipment.
- To handle hot parts, use proper tools and/or wear heavy, insulated welding gloves and clothing to prevent burns.



FUMES AND GASES can be hazardous.

Welding produces fumes and gases. Breathing these fumes and gases can be hazardous to your health.

- Keep your head out of the fumes. Do not breathe the fumes.
- If inside, ventilate the area and/or use local forced ventilation at the arc to remove welding fumes and gases. The recommended way to determine adequate ventilation is to sample for the composition and quantity of fumes and gases to which personnel are exposed.
- If ventilation is poor, wear an approved air-supplied respirator.
- Read and understand the Safety Data Sheets (SDSs) and the manufacturer's instructions for adhesives, coatings, cleaners, consumables, coolants, degreasers, fluxes, and metals.
- Work in a confined space only if it is well ventilated, or while wearing an air-supplied respirator. Always have a trained watch-person nearby. Welding fumes and gases can displace air and lower the oxygen level causing injury or death. Be sure the breathing air is safe.
- Do not weld in locations near degreasing, cleaning, or spraying operations. The heat and rays of the arc can react with vapors to form highly toxic and irritating gases.
- Do not weld on coated metals, such as galvanized, lead, or cadmium plated steel, unless the coating is removed from the weld area, the area is well ventilated, and while wearing an air-supplied respirator. The coatings and any metals containing these elements can give off toxic fumes if welded.



ARC RAYS can burn eyes and skin.

Arc rays from the welding process produce intense visible and invisible (ultraviolet and infrared) rays that can burn eyes and skin. Sparks fly off from the weld.

- Wear an approved welding helmet fitted with a proper shade of filter lenses to protect your face and eyes from arc rays and sparks when welding or watching (see ANSI Z49.1 and Z87.1 listed in Safety Standards).
- Wear approved safety glasses with side shields under your helmet.
- Use protective screens or barriers to protect others from flash, glare and sparks; warn others not to watch the arc.
- Wear body protection made from durable, flame-resistant material (leather, heavy cotton, wool). Body protection includes oil-free clothing such as leather gloves, heavy shirt, cuffless trousers, high shoes, and a cap.



WELDING can cause fire or explosion.

Welding on closed containers, such as tanks, drums, or pipes, can cause them to blow up. Sparks can fly off from the welding arc. The flying sparks, hot workpiece, and hot equipment can cause fires and burns. Accidental contact of electrode to metal objects can cause sparks, explosion, overheating, or fire. Check and be sure the area is safe before doing any welding.

- Remove all flammables within 35 ft (10.7 m) of the welding arc. If this is not possible, tightly cover them with approved covers.
- Do not weld where flying sparks can strike flammable material.
- Protect yourself and others from flying sparks and hot metal.
- Be alert that welding sparks and hot materials from welding can easily go through small cracks and openings to adjacent areas.
- Watch for fire, and keep a fire extinguisher nearby.
- Be aware that welding on a ceiling, floor, bulkhead, or partition can cause fire on the hidden side.
- Do not weld on containers that have held combustibles, or on closed containers such as tanks, drums, or pipes unless they are properly prepared according to AWS F4.1 and AWS A6.0 (see Safety Standards).
- Do not weld where the atmosphere can contain flammable dust, gas, or liquid vapors (such as gasoline).
- Connect work cable to the work as close to the welding area as practical to prevent welding current from traveling long, possibly unknown paths and causing electric shock, sparks, and fire hazards.
- Do not use welder to thaw frozen pipes.

- Remove stick electrode from holder or cut off welding wire at contact tip when not in use.
- Wear body protection made from durable, flame-resistant material (leather, heavy cotton, wool). Body protection includes oil-free clothing such as leather gloves, heavy shirt, cuffless trousers, high shoes, and a cap.
- Remove any combustibles, such as a butane lighter or matches, from your person before doing any welding.
- After completion of work, inspect area to ensure it is free of sparks, glowing embers, and flames.
- Use only correct fuses or circuit breakers. Do not oversize or bypass them.
- Follow requirements in OSHA 1910.252 (a) (2) (iv) and NFPA 51B for hot work and have a fire watcher and extinguisher nearby.
- Read and understand the Safety Data Sheets (SDSs) and the manufacturer's instructions for adhesives, coatings, cleaners, consumables, coolants, degreasers, fluxes, and metals.

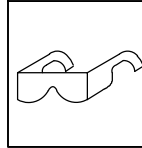

FLYING METAL or DIRT can injure eyes.

- Welding, chipping, wire brushing, and grinding cause sparks and flying metal. As welds cool, they can throw off slag.
- Wear approved safety glasses with side shields even under your welding helmet.



BUILDUP OF GAS can injure or kill.

- Shut off compressed gas supply when not in use.
- Always ventilate confined spaces or use approved air-supplied respirator.

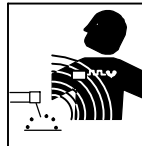

ELECTRIC AND MAGNETIC FIELDS (EMF) can affect Implanted Medical Devices.

- Wearers of Pacemakers and other Implanted Medical Devices should keep away.
- Implanted Medical Device wearers should consult their doctor and the device manufacturer before going near arc welding, spot welding, gouging, plasma arc cutting, or induction heating operations.

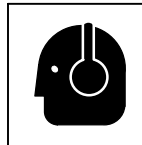

NOISE can damage hearing.

Noise from some processes or equipment can damage hearing.

- Wear approved ear protection if noise level is high.

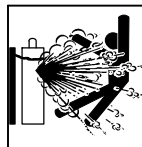

CYLINDERS can explode if damaged.

Compressed gas cylinders contain gas under high pressure. If damaged, a cylinder can explode. Since gas cylinders are normally part of the welding process, be sure to treat them carefully.

- Protect compressed gas cylinders from excessive heat, mechanical shocks, physical damage, slag, open flames, sparks, and arcs.
- Install cylinders in an upright position by securing to a stationary support or cylinder rack to prevent falling or tipping.
- Keep cylinders away from any welding or other electrical circuits.
- Never drape a welding torch over a gas cylinder.
- Never allow a welding electrode to touch any cylinder.
- Never weld on a pressurized cylinder – explosion will result.
- Use only correct compressed gas cylinders, regulators, hoses, and fittings designed for the specific application; maintain them and associated parts in good condition.
- Turn face away from valve outlet when opening cylinder valve. Do not stand in front of or behind the regulator when opening the valve.
- Keep protective cap in place over valve except when cylinder is in use or connected for use.
- Use the right equipment, correct procedures, and sufficient number of persons to lift and move cylinders.
- Read and follow instructions on compressed gas cylinders, associated equipment, and Compressed Gas Association (CGA) publication P-1 listed in Safety Standards.

1-3. Additional Symbols For Installation, Operation, And Maintenance



FIRE OR EXPLOSION hazard.

- Do not install or place unit on, over, or near combustible surfaces.
- Do not install unit near flammables.
- Do not overload building wiring – be sure power supply system is properly sized, rated, and protected to handle this unit.



FALLING EQUIPMENT can injure.

- Use lifting eye to lift unit only, NOT running gear, gas cylinders, or any other accessories.
- Use equipment of adequate capacity to lift and support unit.
- If using lift forks to move unit, be sure forks are long enough to extend beyond opposite side of unit.
- Keep equipment (cables and cords) away from moving vehicles when working from an aerial location.
- Follow the guidelines in the Applications Manual for the Revised NIOSH Lifting Equation (Publication No. 94–110) when manually lifting heavy parts or equipment.



OVERUSE can cause OVERHEATING

- Allow cooling period; follow rated duty cycle.
- Reduce current or reduce duty cycle before starting to weld again.
- Do not block or filter airflow to unit.

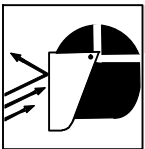

FLYING SPARKS can injure.

- Wear a face shield to protect eyes and face.
- Shape tungsten electrode only on grinder with proper guards in a safe location wearing proper face, hand, and body protection.
- Sparks can cause fires — keep flammables away.

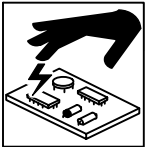

STATIC (ESD) can damage PC boards.

- Put on grounded wrist strap BEFORE handling boards or parts.
- Use proper static-proof bags and boxes to store, move, or ship PC boards.



MOVING PARTS can injure.

- Keep away from moving parts.
- Keep away from pinch points such as drive rolls.



WELDING WIRE can injure.

- Do not press gun trigger until instructed to do so.
- Do not point gun toward any part of the body, other people, or any metal when threading welding wire.



BATTERY EXPLOSION can injure.

- Do not use welder to charge batteries or jump start vehicles unless it has a battery charging feature designed for this purpose.



MOVING PARTS can injure.

- Keep away from moving parts such as fans.
- Keep all doors, panels, covers, and guards closed and securely in place.
- Have only qualified persons remove doors, panels, covers, or guards for maintenance and troubleshooting as necessary.
- Reinstall doors, panels, covers, or guards when maintenance is finished and before reconnecting input power.

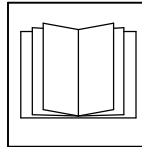

READ INSTRUCTIONS.

- Read and follow all labels and the Owner's Manual carefully before installing, operating, or servicing unit. Read the safety information at the beginning of the manual and in each section.
- Use only genuine replacement parts from the manufacturer.
- Perform installation, maintenance, and service according to the Owner's Manuals, industry standards, and national, state, and local codes.

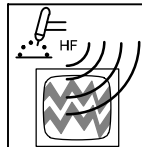

H.F. RADIATION can cause interference.

- High-frequency (H.F.) can interfere with radio navigation, safety services, computers, and communications equipment.
- Have only qualified persons familiar with electronic equipment perform this installation.
- The user is responsible for having a qualified electrician promptly correct any interference problem resulting from the installation.
- If notified by the FCC about interference, stop using the equipment at once.
- Have the installation regularly checked and maintained.
- Keep high-frequency source doors and panels tightly shut, keep spark gaps at correct setting, and use grounding and shielding to minimize the possibility of interference.

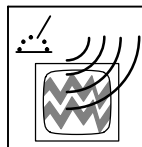

ARC WELDING can cause interference.

- Electromagnetic energy can interfere with sensitive electronic equipment such as computers and computer-driven equipment such as robots.
- Be sure all equipment in the welding area is electromagnetically compatible.
- To reduce possible interference, keep weld cables as short as possible, close together, and down low, such as on the floor.
- Locate welding operation 100 meters from any sensitive electronic equipment.
- Be sure this welding machine is installed and grounded according to this manual.
- If interference still occurs, the user must take extra measures such as moving the welding machine, using shielded cables, using line filters, or shielding the work area.

1-4. California Proposition 65 Warnings

 **Welding or cutting equipment produces fumes or gases which contain chemicals known to the State of California to cause birth defects and, in some cases, cancer. (California Health & Safety Code Section 25249.5 et seq.)**

 **This product contains chemicals, including lead, known to the state of California to cause cancer, birth defects, or other reproductive harm. *Wash hands after use.***

1-5. Principal Safety Standards

Safety in Welding, Cutting, and Allied Processes, ANSI Standard Z49.1, is available as a free download from the American Welding Society at <http://www.aws.org> or purchased from Global Engineering Documents (phone: 1-877-413-5184, website: www.global.ihs.com).

Safe Practices for the Preparation of Containers and Piping for Welding and Cutting, American Welding Society Standard AWS F4.1, from Global Engineering Documents (phone: 1-877-413-5184, website: www.global.ihs.com).

Safe Practices for Welding and Cutting Containers that have Held Combustibles, American Welding Society Standard AWS A6.0, from Global Engineering Documents (phone: 1-877-413-5184, website: www.global.ihs.com).

National Electrical Code, NFPA Standard 70, from National Fire Protection Association, Quincy, MA 02269 (phone: 1-800-344-3555, website: www.nfpa.org and www.sparky.org).

Safe Handling of Compressed Gases in Cylinders, CGA Pamphlet P-1, from Compressed Gas Association, 14501 George Carter Way, Suite 103, Chantilly, VA 20151 (phone: 703-788-2700, website: www.cga-net.com).

Safety in Welding, Cutting, and Allied Processes, CSA Standard W117.2, from Canadian Standards Association, Standards Sales, 5060 Spectrum Way, Suite 100, Mississauga, Ontario, Canada L4W 5N5 (phone: 800-463-6727, website: www.csagroup.org).

Safe Practice For Occupational And Educational Eye And Face Protection, ANSI Standard Z87.1, from American National Standards Institute, 25 West 43rd Street, New York, NY 10036 (phone: 212-642-4900, website: www.ansi.org).

Standard for Fire Prevention During Welding, Cutting, and Other Hot Work, NFPA Standard 51B, from National Fire Protection Association, Quincy, MA 02269 (phone: 1-800-344-3555, website: www.nfpa.org).

OSHA, Occupational Safety and Health Standards for General Industry, Title 29, Code of Federal Regulations (CFR), Part 1910, Subpart Q, and Part 1926, Subpart J, from U.S. Government Printing Office, Superintendent of Documents, P.O. Box 371954, Pittsburgh, PA 15250-7954 (phone: 1-866-512-1800) (there are 10 OSHA Regional Offices—phone for Region 5, Chicago, is 312-353-2220, website: www.osha.gov).

Applications Manual for the Revised NIOSH Lifting Equation, The National Institute for Occupational Safety and Health (NIOSH), 1600 Clifton Rd, Atlanta, GA 30329-4027 (phone: 1-800-232-4636, website: www.cdc.gov/NIOSH).

1-6. EMF Information

Electric current flowing through any conductor causes localized electric and magnetic fields (EMF). The current from arc welding (and allied processes including spot welding, gouging, plasma arc cutting, and induction heating operations) creates an EMF field around the welding circuit. EMF fields can interfere with some medical implants, e.g. pacemakers. Protective measures for persons wearing medical implants have to be taken. For example, restrict access for passers-by or conduct individual risk assessment for welders. All welders should use the following procedures in order to minimize exposure to EMF fields from the welding circuit:

1. Keep cables close together by twisting or taping them, or using a cable cover.
2. Do not place your body between welding cables. Arrange cables to one side and away from the operator.
3. Do not coil or drape cables around your body.

4. Keep head and trunk as far away from the equipment in the welding circuit as possible.
5. Connect work clamp to workpiece as close to the weld as possible.
6. Do not work next to, sit or lean on the welding power source.
7. Do not weld whilst carrying the welding power source or wire feeder.

About Implanted Medical Devices:

Implanted Medical Device wearers should consult their doctor and the device manufacturer before performing or going near arc welding, spot welding, gouging, plasma arc cutting, or induction heating operations. If cleared by your doctor, then following the above procedures is recommended.

SECTION 2 – CONSIGNES DE SÉCURITÉ – LIRE AVANT UTILISATION

fre_som_2015-09

! Pour écarter les risques de blessure pour vous-même et pour autrui — lire, appliquer et ranger en lieu sûr ces consignes relatives aux précautions de sécurité et au mode opératoire.

2-1. Symboles utilisés



DANGER! – Indique une situation dangereuse qui si on l'évite pas peut donner la mort ou des blessures graves. Les dangers possibles sont montrés par les symboles joints ou sont expliqués dans le texte.



Indique une situation dangereuse qui si on l'évite pas peut donner la mort ou des blessures graves. Les dangers possibles sont montrés par les symboles joints ou sont expliqués dans le texte.

AVIS – Indique des déclarations pas en relation avec des blessures personnelles.

 Indique des instructions spécifiques.



Ce groupe de symboles veut dire Avertissement! Attention! DANGER DE CHOC ELECTRIQUE, PIECES EN MOUVEMENT, et PIECES CHAUDES. Consulter les symboles et les instructions ci-dessous y afférant pour les actions nécessaires afin d'éviter le danger.

2-2. Dangers relatifs au soudage à l'arc



Les symboles représentés ci-dessous sont utilisés dans ce manuel pour attirer l'attention et identifier les dangers possibles. En présence de l'un de ces symboles, prendre garde et suivre les instructions afférentes pour éviter tout risque. Les instructions en matière de sécurité indiquées ci-dessous ne constituent qu'un sommaire des instructions de sécurité plus complètes fournies dans les normes de sécurité énumérées dans la Section 2-5. Lire et observer toutes les normes de sécurité.



Seul un personnel qualifié est autorisé à installer, faire fonctionner, entretenir et réparer cet appareil.



Pendant le fonctionnement, maintenir à distance toutes les personnes, notamment les enfants de l'appareil.



UNE DÉCHARGE ÉLECTRIQUE peut entraîner la mort.

Le contact d'organes électriques sous tension peut provoquer des accidents mortels ou des brûlures graves. Le circuit de l'électrode et de la pièce est sous tension lorsque le courant est délivré à la sortie. Le circuit d'alimentation et les circuits internes de la machine sont également sous tension lorsque l'alimentation est sur Marche. Dans le mode de soudage avec du fil, le fil, le dérouleur, le bloc de commande du rouleau et toutes les parties métalliques en contact avec le fil sont sous tension électrique. Un équipement installé ou mis à la terre de manière incorrecte ou impropre constitue un danger.

- Ne pas toucher aux pièces électriques sous tension.
- Porter des gants isolants et des vêtements de protection secs et sans trous.
- S'isoler de la pièce à couper et du sol en utilisant des housses ou des tapis assez grands afin d'éviter tout contact physique avec la pièce à couper ou le sol.
- Ne pas se servir de source électrique à courant électrique dans les zones humides, dans les endroits confinés ou là où on risque de tomber.
- Se servir d'une source électrique à courant électrique UNIQUEMENT si le procédé de soudage le demande.
- Si l'utilisation d'une source électrique à courant électrique s'avère nécessaire, se servir de la fonction de télécommande si l'appareil en est équipé.
- D'autres consignes de sécurité sont nécessaires dans les conditions suivantes : risques électriques dans un environnement humide ou si l'on porte des vêtements mouillés ; sur des structures métalliques telles que sols, grilles ou échafaudages ; en position coincée comme assise, à genoux ou couchée ; ou s'il y a un risque élevé de contact inévitable ou accidentel avec la pièce à souder ou le sol. Dans ces conditions, utiliser les équipements suivants, dans l'ordre indiqué : 1) un poste à souder DC à tension constante (à fil), 2) un poste à souder DC manuel (électrode) ou 3) un poste à souder AC à tension à vide réduite. Dans la plupart des situations, l'utilisation d'un poste à souder DC à fil à tension constante est recommandée. En outre, ne pas travailler seul !

- Couper l'alimentation ou arrêter le moteur avant de procéder à l'installation, à la réparation ou à l'entretien de l'appareil. Déverrouiller l'alimentation selon la norme OSHA 29 CFR 1910.147 (voir normes de sécurité).
- Installez, mettez à la terre et utilisez correctement cet équipement conformément à son Manuel d'Utilisation et aux réglementations nationales, gouvernementales et locales.
- Toujours vérifier la terre du cordon d'alimentation. Vérifier et s'assurer que le fil de terre du cordon d'alimentation est bien raccordé à la borne de terre du sectionneur ou que la fiche du cordon est raccordée à une prise correctement mise à la terre.
- En effectuant les raccordements d'entrée, fixer d'abord le conducteur de mise à la terre approprié et contre-vérifier les connexions.
- Les câbles doivent être exempts d'humidité, d'huile et de graisse; protégez-les contre les étincelles et les pièces métalliques chaudes.
- Vérifier fréquemment le cordon d'alimentation et le conducteur de mise à la terre afin de s'assurer qu'il n'est pas altéré ou dénudé –, le remplacer immédiatement s'il l'est –. Un fil dénudé peut entraîner la mort.
- L'équipement doit être hors tension lorsqu'il n'est pas utilisé.
- Ne pas utiliser des câbles usés, endommagés, de grosseur insuffisante ou mal épissés.
- Ne pas enrouler les câbles autour du corps.
- Si la pièce soudée doit être mise à la terre, le faire directement avec un câble distinct.
- Ne pas toucher l'électrode quand on est en contact avec la pièce, la terre ou une électrode provenant d'une autre machine.
- Ne pas toucher des porte électrodes connectés à deux machines en même temps à cause de la présence d'une tension à vide doublée.
- N'utiliser qu'un matériel en bon état. Réparer ou remplacer sur-le-champ les pièces endommagées. Entretien l'appareil conformément à ce manuel.
- Porter un harnais de sécurité si l'on doit travailler au-dessus du sol.
- S'assurer que tous les panneaux et couvercles sont correctement en place.
- Fixer le câble de retour de façon à obtenir un bon contact métal-métal avec la pièce à souder ou la table de travail, le plus près possible de la soudure.
- Isoler la pince de masse quand pas mis à la pièce pour éviter le contact avec tout objet métallique.
- Ne pas raccorder plus d'une électrode ou plus d'un câble de masse à une même borne de sortie de soudage. Débrancher le câble pour le procédé non utilisé.
- Utiliser une protection différentielle lors de l'utilisation d'un équipement auxiliaire dans des endroits humides ou mouillés.

Il reste une TENSION DC NON NÉGLIGEABLE dans les sources de soudage onduleur UNE FOIS l'alimentation coupée.

- Arrêter les convertisseurs, débrancher le courant électrique et décharger les condensateurs d'alimentation selon les instructions indiquées dans la partie Entretien avant de toucher les pièces.



LES PIÈCES CHAUDES peuvent provoquer des brûlures.

- Ne pas toucher à mains nues les parties chaudes.
- Prévoir une période de refroidissement avant de travailler à l'équipement.

- Ne pas toucher aux pièces chaudes, utiliser les outils recommandés et porter des gants de soudage et des vêtements épais pour éviter les brûlures.

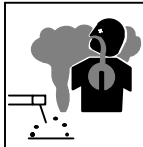

LES FUMÉES ET LES GAZ peuvent être dangereux.

Le soudage génère des fumées et des gaz. Leur inhalation peut être dangereux pour votre santé.

- Eloigner votre tête des fumées. Ne pas respirer les fumées.
- À l'intérieur, ventiler la zone et/ou utiliser une ventilation forcée au niveau de l'arc pour l'évacuation des fumées et des gaz de soudage. Pour déterminer la bonne ventilation, il est recommandé de procéder à un prélèvement pour la composition et la quantité de fumées et de gaz auxquels est exposé le personnel.
- Si la ventilation est médiocre, porter un respirateur anti-vapeurs approuvé.
- Lire et comprendre les fiches de données de sécurité et les instructions du fabricant concernant les adhésifs, les revêtements, les nettoyants, les consommables, les produits de refroidissement, les dégraisseurs, les flux et les métaux.
- Travailler dans un espace fermé seulement s'il est bien ventilé ou en portant un respirateur à alimentation d'air. Demander toujours à un surveillant dûment formé de se tenir à proximité. Des fumées et des gaz de soudage peuvent déplacer l'air et abaisser le niveau d'oxygène provoquant des blessures ou des accidents mortels. S'assurer que l'air de respiration ne présente aucun danger.
- Ne pas souder dans des endroits situés à proximité d'opérations de dégraissage, de nettoyage ou de pulvérisation. La chaleur et les rayons de l'arc peuvent réagir en présence de vapeurs et former des gaz hautement toxiques et irritants.
- Ne pas souder des métaux munis d'un revêtement, tels que l'acier galvanisé, plaqué en plomb ou au cadmium à moins que le revêtement n'ait été enlevé dans la zone de soudure, que l'endroit soit bien ventilé, et en portant un respirateur à alimentation d'air. Les revêtements et tous les métaux renfermant ces éléments peuvent dégager des fumées toxiques en cas de soudage.



LES RAYONS DE L'ARC peuvent provoquer des brûlures dans les yeux et sur la peau.

Le rayonnement de l'arc du procédé de soudage génère des rayons visibles et invisibles intenses (ultraviolets et infrarouges) susceptibles de provoquer des brûlures dans les yeux et sur la peau. Des étincelles sont projetées pendant le soudage.

- Porter un casque de soudage approuvé muni de verres filtrants appropriés pour protéger visage et yeux pour protéger votre visage et vos yeux pendant le soudage ou pour regarder (voir ANSI Z49.1 et Z87.1 énuméré dans les normes de sécurité).
- Porter des lunettes de sécurité avec écrans latéraux même sous votre casque.
- Avoir recours à des écrans protecteurs ou à des rideaux pour protéger les autres contre les rayonnements les éblouissements et les étincelles ; prévenir toute personne sur les lieux de ne pas regarder l'arc.
- Porter un équipement de protection pour le corps fait d'un matériau résistant et ignifuge (cuir, coton robuste, laine). La protection du corps comporte des vêtements sans huile comme par ex. des gants de cuir, une chemise solide, des pantalons sans revers, des chaussures hautes et une casquette.



LE SOUDAGE peut provoquer un incendie ou une explosion.

Le soudage effectué sur des conteneurs fermés tels que des réservoirs, tambours ou des conduites peut provoquer leur éclatement. Des étincelles peuvent être projetées de l'arc de soudure. La projection d'étincelles, des

pièces chaudes et des équipements chauds peut provoquer des incendies et des brûlures. Le contact accidentel de l'électrode avec des objets métalliques peut provoquer des étincelles, une explosion, un sur-

chauffement ou un incendie. Avant de commencer le soudage, vérifier et s'assurer que l'endroit ne présente pas de danger.

- Déplacer toutes les substances inflammables à une distance de 10,7 m de l'arc de soudage. En cas d'impossibilité les recouvrir soigneusement avec des protections homologués.
- Ne pas souder dans un endroit où des étincelles peuvent tomber sur des substances inflammables.
- Se protéger et d'autres personnes de la projection d'étincelles et de métal chaud.
- Des étincelles et des matériaux chauds du soudage peuvent facilement passer dans d'autres zones en traversant de petites fissures et des ouvertures.
- Surveiller tout déclenchement d'incendie et tenir un extincteur à proximité.
- Le soudage effectué sur un plafond, plancher, paroi ou séparation peut déclencher un incendie de l'autre côté.
- Ne pas effectuer le soudage sur des conteneurs fermés tels que des réservoirs, tambours, ou conduites, à moins qu'ils n'aient été préparés correctement conformément à AWS F4.1 et AWS A6.0 (voir les Normes de Sécurité).
- Ne pas souder là où l'air ambiant pourrait contenir des poussières, gaz ou émanations inflammables (vapeur d'essence, par exemple).
- Brancher le câble de masse sur la pièce la plus près possible de la zone de soudage pour éviter le transport du courant sur une longue distance par des chemins inconnus éventuels en provoquant des risques d'électrocution, d'étincelles et d'incendie.
- Ne pas utiliser le poste de soudage pour dégeler des conduites gelées.
- En cas de non utilisation, enlever la baguette d'électrode du porte-électrode ou couper le fil à la pointe de contact.
- Porter un équipement de protection pour le corps fait d'un matériau résistant et ignifuge (cuir, coton robuste, laine). La protection du corps comporte des vêtements sans huile comme par ex. des gants de cuir, une chemise solide, des pantalons sans revers, des chaussures hautes et une casquette.
- Avant de souder, retirer toute substance combustible de vos poches telles qu'un allumeur au butane ou des allumettes.
- Une fois le travail achevé, assurez-vous qu'il ne reste aucune trace d'étincelles incandescentes ni de flammes.
- Utiliser exclusivement des fusibles ou coupe-circuits appropriés. Ne pas augmenter leur puissance; ne pas les ponter.
- Suivre les recommandations dans OSHA 1910.252(a)(2)(iv) et NFPA 51B pour les travaux à chaud et avoir de la surveillance et un extincteur à proximité.
- Lire et comprendre les fiches de données de sécurité et les instructions du fabricant concernant les adhésifs, les revêtements, les nettoyants, les consommables, les produits de refroidissement, les dégraisseurs, les flux et les métaux.

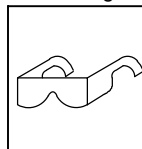

DES PIÈCES DE METAL ou DES SALETES peuvent provoquer des blessures dans les yeux.

- Le soudage, l'écaillage, le passage de la pièce à la brosse en fil de fer, et le meulage génèrent des étincelles et des particules métalliques volantes. Pendant la période de refroidissement des soudures, elles risquent de projeter du laitier.
- Porter des lunettes de sécurité avec écrans latéraux ou un écran facial.



LES ACCUMULATIONS DE GAZ risquent de provoquer des blessures ou même la mort.

- Fermer l'alimentation du gaz comprimé en cas de non utilisation.
- Veiller toujours à bien aérer les espaces confinés ou se servir d'un respirateur d'adduction d'air homologué.

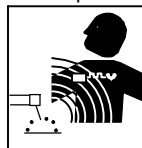

Les CHAMPS ÉLECTROMAGNÉTIQUES (CEM) peuvent affecter les implants médicaux.

- Les porteurs de stimulateurs cardiaques et autres implants médicaux doivent rester à distance.
- Les porteurs d'implants médicaux doivent consulter leur médecin et le fabricant du dispositif avant de s'approcher de la zone où se

déroule du soudage à l'arc, du soudage par points, du gougeage, de la découpe plasma ou une opération de chauffage par induction.

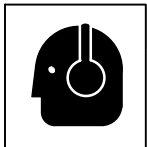

LE BRUIT peut endommager l'ouïe.

Le bruit des processus et des équipements peut affecter l'ouïe.

- Porter des protections approuvées pour les oreilles si le niveau sonore est trop élevé.

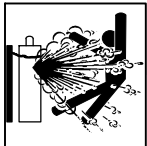

LES BOUTEILLES peuvent exploser si elles sont endommagées.

Les bouteilles de gaz comprimé contiennent du gaz sous haute pression. Si une bouteille est endommagée, elle peut exploser. Du fait que

les bouteilles de gaz font normalement partie du procédé de soudage, les manipuler avec précaution.

- Protéger les bouteilles de gaz comprimé d'une chaleur excessive, des chocs mécaniques, des dommages physiques, du laitier, des flammes ouvertes, des étincelles et des arcs.

- Placer les bouteilles debout en les fixant dans un support stationnaire ou dans un porte-bouteilles pour les empêcher de tomber ou de se renverser.
- Tenir les bouteilles éloignées des circuits de soudage ou autres circuits électriques.
- Ne jamais placer une torche de soudage sur une bouteille à gaz.
- Une électrode de soudage ne doit jamais entrer en contact avec une bouteille.
- Ne jamais souder une bouteille pressurisée – risque d'explosion.
- Utiliser seulement des bouteilles de gaz comprimé, régulateurs, tuyaux et raccords convenables pour cette application spécifique; les maintenir ainsi que les éléments associés en bon état.
- Tourner le dos à la sortie de vanne lors de l'ouverture de la vanne de la bouteille. Ne pas se tenir devant ou derrière le régulateur lors de l'ouverture de la vanne.
- Le couvercle du détendeur doit toujours être en place, sauf lorsque la bouteille est utilisée ou qu'elle est reliée pour usage ultérieur.
- Utiliser les équipements corrects, les bonnes procédures et suffisamment de personnes pour soulever et déplacer les bouteilles.
- Lire et suivre les instructions sur les bouteilles de gaz comprimé, l'équipement connexe et le dépliant P-1 de la CGA (Compressed Gas Association) mentionné dans les principales normes de sécurité.

2-3. Dangers supplémentaires en relation avec l'installation, le fonctionnement et la maintenance



Risque D'INCENDIE OU D'EXPLOSION.

- Ne pas placer l'appareil sur, au-dessus ou à proximité de surfaces inflammables.
- Ne pas installer l'appareil à proximité de produits inflammables.

- Ne pas surcharger l'installation électrique – s'assurer que l'alimentation est correctement dimensionnée et protégée avant de mettre l'appareil en service.



LA CHUTE DE L'ÉQUIPEMENT peut provoquer des blessures.

- Utiliser l'anneau de levage uniquement pour soulever l'appareil, NON PAS les chariots, les bouteilles de gaz ou tout autre accessoire.

- Utiliser un équipement de levage de capacité suffisante pour lever l'appareil.
- En utilisant des fourches de levage pour déplacer l'unité, s'assurer que les fourches sont suffisamment longues pour dépasser du côté opposé de l'appareil.
- Tenir l'équipement (câbles et cordons) à distance des véhicules mobiles lors de toute opération en hauteur.
- Suivre les consignes du Manuel des applications pour l'équation de levage NIOSH révisée (Publication N°94-110) lors du levage manuel de pièces ou équipements lourds.

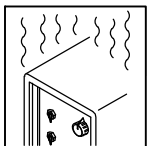

L'EMPLOI EXCESSIF peut SURCHAUFFER L'ÉQUIPEMENT.

- Prévoir une période de refroidissement ; respecter le cycle opératoire nominal.
- Réduire le courant ou le facteur de marche avant de poursuivre le soudage.

- Ne pas obstruer les passages d'air du poste.

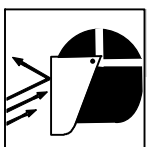

LES ÉTINCELLES PROJÉTÉES peuvent provoquer des blessures.

- Porter un écran facial pour protéger le visage et les yeux.

• Affûter l'électrode au tungstène uniquement à la meuleuse dotée de protecteurs. Cette manœuvre est à exécuter dans un endroit sûr lorsque l'on porte l'équipement homologué de protection du visage, des mains et du corps.

- Les étincelles risquent de causer un incendie – éloigner toute substance inflammable.

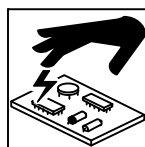

LES CHARGES ÉLECTROSTATIQUES peuvent endommager les circuits imprimés.

- Établir la connexion avec la barrette de terre avant de manipuler des cartes ou des pièces.

- Utiliser des pochettes et des boîtes antistatiques pour stocker, déplacer ou expédier des cartes de circuits imprimés.

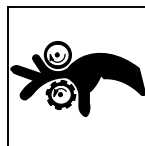

Les PIÈCES MOBILES peuvent causer des blessures.

- Ne pas s'approcher des organes mobiles.
- Ne pas s'approcher des points de coincement tels que des rouleaux de commande.



LES FILS DE SOUDAGE peuvent provoquer des blessures.

- Ne pas appuyer sur la gâchette avant d'en avoir reçu l'instruction.

- Ne pas diriger le pistolet vers soi, d'autres personnes ou toute pièce mécanique en engageant le fil de soudage.

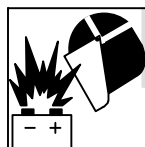

L'EXPLOSION DE LA BATTERIE peut provoquer des blessures.

- Ne pas utiliser l'appareil de soudage pour charger des batteries ou faire démarrer des véhicules à l'aide de câbles de démarrage, sauf si l'appareil dispose d'une fonctionnalité de charge de batterie destinée à cet usage.



Les PIÈCES MOBILES peuvent causer des blessures.

- S'abstenir de toucher des organes mobiles tels que des ventilateurs.

- Maintenir fermés et verrouillés les portes, panneaux, recouvrements et dispositifs de protection.

- Lorsque cela est nécessaire pour des travaux d'entretien et de dépannage, faire retirer les portes, panneaux, recouvrements ou dispositifs de protection uniquement par du personnel qualifié.
- Remettre les portes, panneaux, recouvrements ou dispositifs de protection quand l'entretien est terminé et avant de rebrancher l'alimentation électrique.

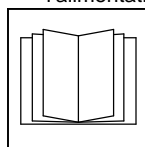

LIRE LES INSTRUCTIONS.

- Lire et appliquer les instructions sur les étiquettes et le Mode d'emploi avant l'installation, l'utilisation ou l'entretien de l'appareil. Lire les informations de sécurité au début du manuel et dans chaque section.

- N'utiliser que les pièces de rechange recommandées par le constructeur.
- Effectuer l'installation, l'entretien et toute intervention selon les manuels d'utilisateurs, les normes nationales, provinciales et de l'industrie, ainsi que les codes municipaux.

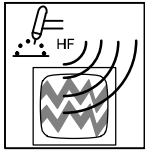

LE RAYONNEMENT HAUTE FRÉQUENCE (H.F.) risque de provoquer des interférences.

- Le rayonnement haute fréquence (H.F.) peut provoquer des interférences avec les équipements de radio-navigation et de communication, les services de sécurité et les ordinateurs.
- Demander seulement à des personnes qualifiées familiarisées avec des équipements électroniques de faire fonctionner l'installation.
- L'utilisateur est tenu de faire corriger rapidement par un électricien qualifié les interférences résultant de l'installation.
- Si le FCC signale des interférences, arrêter immédiatement l'appareil.
- Effectuer régulièrement le contrôle et l'entretien de l'installation.
- Maintenir soigneusement fermés les portes et les panneaux des sources de haute fréquence, maintenir les éclateurs à une distance correcte et utiliser une terre et un blindage pour réduire les interférences éventuelles.

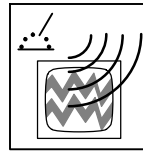

LE SOUDAGE À L'ARC risque de provoquer des interférences.

- L'énergie électromagnétique risque de provoquer des interférences pour l'équipement électronique sensible tel que les ordinateurs et l'équipement commandé par ordinateur tel que les robots.
- Veiller à ce que tout l'équipement de la zone de soudage soit compatible électromagnétiquement.
- Pour réduire la possibilité d'interférence, maintenir les câbles de soudage aussi courts que possible, les grouper, et les poser aussi bas que possible (ex. par terre).
- Veiller à souder à une distance de 100 mètres de tout équipement électronique sensible.
- Veiller à ce que ce poste de soudage soit posé et mis à la terre conformément à ce mode d'emploi.
- En cas d'interférences après avoir pris les mesures précédentes, il incombe à l'utilisateur de prendre des mesures supplémentaires telles que le déplacement du poste, l'utilisation de câbles blindés, l'utilisation de filtres de ligne ou la pose de protecteurs dans la zone de travail.

2-4. Proposition californienne 65 Avertissements

⚠ Les équipements de soudage et de coupage produisent des fumées et des gaz qui contiennent des produits chimiques dont l'État de Californie reconnaît qu'ils provoquent des malformations congénitales et, dans certains cas, des cancers. (Code de santé et de sécurité de Californie, chapitre 25249.5 et suivants)

⚠ Ce produit contient des produits chimiques, notamment du plomb, dont l'État de Californie reconnaît qu'ils provoquent des cancers, des malformations congénitales ou d'autres problèmes de procréation. Se laver les mains après utilisation.

2-5. Principales normes de sécurité

Safety in Welding, Cutting, and Allied Processes, ANSI Standard Z49.1, is available as a free download from the American Welding Society at <http://www.aws.org> or purchased from Global Engineering Documents (phone: 1-877-413-5184, website: www.global.ihs.com).

Safe Practices for the Preparation of Containers and Piping for Welding and Cutting, American Welding Society Standard AWS F4.1, from Global Engineering Documents (phone: 1-877-413-5184, website: www.global.ihs.com).

Safe Practices for Welding and Cutting Containers that have Held Combustibles, American Welding Society Standard AWS A6.0, from Global Engineering Documents (phone: 1-877-413-5184, website: www.global.ihs.com).

National Electrical Code, NFPA Standard 70, from National Fire Protection Association, Quincy, MA 02269 (phone: 1-800-344-3555, website: www.nfpa.org and www.sparky.org).

Safe Handling of Compressed Gases in Cylinders, CGA Pamphlet P-1, from Compressed Gas Association, 14501 George Carter Way, Suite 103, Chantilly, VA 20151 (phone: 703-788-2700, website: www.cganet.com).

Safety in Welding, Cutting, and Allied Processes, CSA Standard W117.2, from Canadian Standards Association, Standards Sales, 5060

Spectrum Way, Suite 100, Mississauga, Ontario, Canada L4W 5N5 (phone: 800-463-6727, website: www.csagroup.org).

Safe Practice For Occupational And Educational Eye And Face Protection, ANSI Standard Z87.1, from American National Standards Institute, 25 West 43rd Street, New York, NY 10036 (phone: 212-642-4900, website: www.ansi.org).

Standard for Fire Prevention During Welding, Cutting, and Other Hot Work, NFPA Standard 51B, from National Fire Protection Association, Quincy, MA 02269 (phone: 1-800-344-3555, website: www.nfpa.org).

OSHA, Occupational Safety and Health Standards for General Industry, Title 29, Code of Federal Regulations (CFR), Part 1910, Subpart Q, and Part 1926, Subpart J, from U.S. Government Printing Office, Superintendent of Documents, P.O. Box 371954, Pittsburgh, PA 15250-7954 (phone: 1-866-512-1800) (there are 10 OSHA Regional Offices—phone for Region 5, Chicago, is 312-353-2220, website: www.osha.gov).

Applications Manual for the Revised NIOSH Lifting Equation, The National Institute for Occupational Safety and Health (NIOSH), 1600 Clifton Rd, Atlanta, GA 30329-4027 (phone: 1-800-232-4636, website: www.cdc.gov/NIOSH).

2-6. Informations relatives aux CEM

Le courant électrique qui traverse tout conducteur génère des champs électromagnétiques (CEM) à certains endroits. Le courant issu d'un soudage à l'arc (et de procédés connexes, y compris le soudage par points, le gougeage, le découpage plasma et les opérations de chauffage par induction) crée un champ électromagnétique (CEM) autour du circuit de soudage. Les champs électromagnétiques produits peuvent causer interférence à certains implants médicaux, p. ex. les stimulateurs cardiaques. Des mesures de protection pour les porteurs d'implants médicaux doivent être prises: Limiter par exemple tout accès aux passants ou procéder à une évaluation des risques individuels pour les soudeurs. Tous les soudeurs doivent appliquer les procédures suivantes pour minimiser l'exposition aux CEM provenant du circuit de soudage:

1. Rassembler les câbles en les torsadant ou en les attachant avec du ruban adhésif ou avec une housse.
2. Ne pas se tenir au milieu des câbles de soudage. Disposer les

câbles d'un côté et à distance de l'opérateur.

3. Ne pas courber et ne pas entourer les câbles autour de votre corps.
4. Maintenir la tête et le torse aussi loin que possible du matériel du circuit de soudage.
5. Connecter la pince sur la pièce aussi près que possible de la soudure.
6. Ne pas travailler à proximité d'une source de soudage, ni s'asseoir ou se pencher dessus.
7. Ne pas souder tout en portant la source de soudage ou le dévidoir.



En ce qui concerne les implants médicaux :

Les porteurs d'implants doivent d'abord consulter leur médecin avant de s'approcher des opérations de soudage à l'arc, de soudage par points, de gougeage, du coupage plasma ou de chauffage par induction. Si le médecin approuve, il est recommandé de suivre les procédures précédentes.









SECTION 3 – DEFINITIONS









3-1. Manufacturer Safety Symbols And Definitions











Some symbols are found only on CE products.

	<p>Warning! Watch Out! There are possible hazards as shown by the symbols.</p> <p style="text-align: right;">Safe1 2012-05</p>
	<p>When power is applied failed parts can explode or cause other parts to explode.</p> <p style="text-align: right;">Safe26 2012-05</p>

3-2. Miscellaneous Symbols And Definitions

	Shielded Metal Arc (SMAW) Electrode Holder
	Gas Metal Arc Welding (GMAW) Gun
	Scratch Start TIG
	Gas Metal Arc Welding (GMAW)
	Pulse
	Press
	Read Instructions
	On
	Three Phase

	Remote
	Percent
	Increase
	Rated Welding Current
	Off
	Single Phase
	Arc Control
	Gas Tungsten Arc Welding (GTAW) Torch
	Foot Control

	Input Current
	Volts
	Gas Output
	Positive
	Touch Start (GTAW)
	Input
	Input Voltage
	Amperes
	Output
	Negative

SECTION 4 – SPECIFICATIONS

4-1. Features And Benefits

Auto-Line™ Power Management Technology is circuitry that automatically adapts the power source to the primary voltage being applied (see Sections 5-8 and 5-9).

LVC™ Line Voltage Compensation is circuitry that keeps the power source output constant regardless of input power fluctuation.

Wind Tunnel Technology™ circulates air over components that require cooling, not over electronic circuitry, which reduces contaminants and improves reliability in harsh welding environments.

Fan-On-Demand™ cooling system operates only when needed, reducing noise, energy use and the amount of contaminants pulled through the machine.

Thermal Overload Protection automatically shuts down the unit, only when necessary to prevent damage to internal components if the duty cycle is exceeded or air flow and cooling are restricted (see Section 4-6).

Auto Remote Sense enables the unit to automatically sense the connection of a remote control. Operation of the remote control is dependent on the Mode Switch Setting (see Section 6-2).

Lift-Arc™ TIG starts provide a contamination free weld without the use of high frequency in the Lift-Arc TIG Welding Mode (see Section 7-3).

Synergic Pulsed MIG Operation allows single knob control of the arc. As wirefeed speed is increased or decreased, the pulse parameters increase or decrease matching the power output to the wire speed (see Section 6-3).

4-2. Arc Controls

DIG control allows the arc characteristics, soft versus stiff, to be changed for specific applications and electrodes in CC and Stick Welding Modes (see Sections 9-2 and 9-3).

Programmable Hot Start allows the start amperage and time to be changed for CC and Stick Welding Modes (see Sections 9-2 and 9-3).

Inductance influences the arc stiffness, bead width and appearance, and puddle fluidity in MIG and V-Sense Feeder Welding Modes (see Sections 8-2 and 8-8).

SharpArc™ optimizes the size and shape of the arc cone, bead width and appearance, and puddle fluidity in Pulsed MIG Welding Mode (see Section 8-4).

4-3. Serial Number And Rating Label Location

The serial number and rating information for this product is located on the rear panel. Use rating label to determine input power requirements and/or rated output. For future reference, write serial number in space provided on back cover of this manual.

4-4. Unit Specifications

☞ Do not use information in unit specifications table to determine electrical service requirements. See Sections 5-7 thru 5-9 for information on connecting input power.

Input Power	Rated Output	Voltage Range in CV Mode	Amperage Range in CC Mode	Max. Open-Circuit Voltage	RMS Amps Input at Rated Load Output, 60 Hz 3-Phase at NEMA Load Voltages and Class I Rating					KVA	KW
					208 V	230 V	400 V	460 V	575 V		
3-Phase	350 A at 34 VDC, 60% Duty Cycle	10–38 V	5–425 A	75 VDC	40.4	36.1	20.6	17.8	14.1	14.2	13.6
1-Phase	300 A at 32 VDC, 60% Duty Cycle*				60.8	54.6	29.7	25.4	19.9		

*See Section 4-6 for Duty Cycle Rating.

4-5. Dimensions And Weight

Hole Layout Dimensions	
A	11-3/4 in. (298 mm)
B	1-11/16 in. (42 mm)
C	15-3/4 in. (400 mm)
D	19-3/32 in. (485 mm)
E	8-11/16 in. (221 mm)
F	1-17/32 in. (39 mm)
G	1/4-20 UNC -2B thread
Weight	
80 lb (36.3 kg) 93.5 lb (42.4 kg) w/optional 115 VAC	

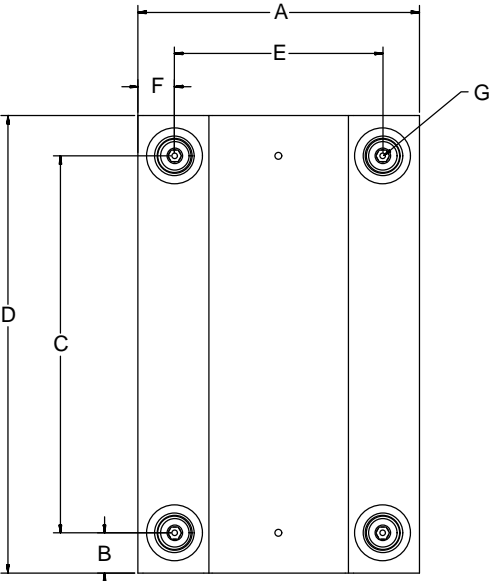
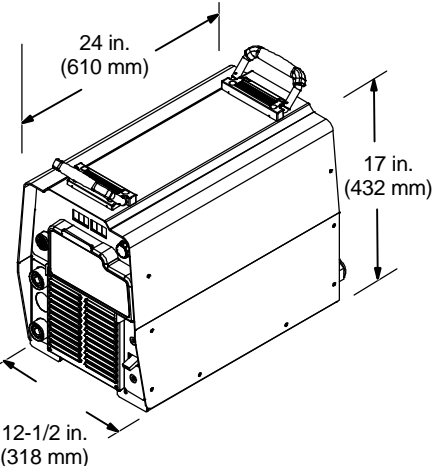
804 801-A

Notes

4-6. Duty Cycle And Overheating



Duty Cycle is percentage of 10 minutes that unit can weld at rated load without overheating.

If unit overheats, output stops, a Help message is displayed and cooling fan runs. Wait fifteen minutes for unit to cool. Reduce amperage or voltage, or duty cycle before welding.

Single Phase Operation: The unit is supplied with a 8 AWG power cord. The rated output with 8 AWG is 300 amps, 32 volts at 40% duty cycle. To achieve 60% duty cycle change cord to 6 AWG.

NOTICE – Exceeding duty cycle can damage unit and void warranty.

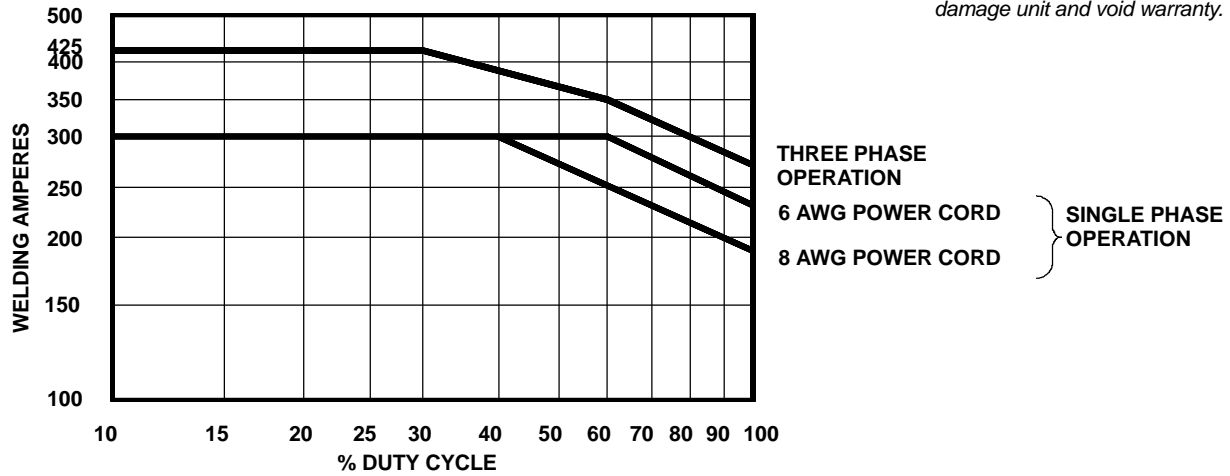

60% Duty Cycle

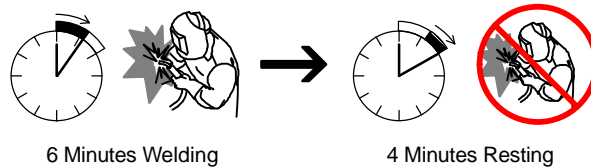

Overheating

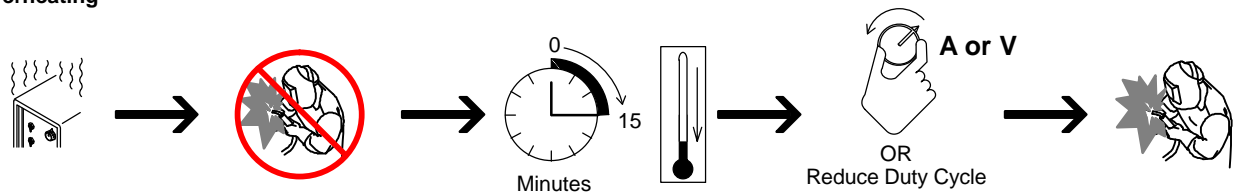

Ref. 216 568-A

4-7. Static Output Characteristics

The static (output) characteristics of the welding power source can be described as *flat* during the GMAW process and *drooping* during the SMAW and GTAW processes. Static characteristics are also affected by control settings (including software), electrode, shielding gas, weldment material, and other factors. Contact the factory for specific information on the static characteristics of the welding power source.

5-2. Selecting Cable Sizes*

NOTICE – The Total Cable Length in Weld Circuit (see table below) is the combined length of both weld cables. For example, if the power source is 100 ft (30 m) from the workpiece, the total cable length in the weld circuit is 200 ft (2 cables x 100 ft). Use the 200 ft (60 m) column to determine cable size.

Welding Amperes	Weld Cable Size** and Total Cable (Copper) Length in Weld Circuit Not Exceeding***							
	100 ft (30 m) or Less		150 ft (45 m)	200 ft (60 m)	250 ft (70 m)	300 ft (90 m)	350 ft (105 m)	400 ft (120 m)
	10 – 60% Duty Cycle AWG (mm ²)	60 – 100% Duty Cycle AWG (mm ²)	10 – 100% Duty Cycle AWG (mm ²)					
100	4 (20)	4 (20)	4 (20)	3 (30)	2 (35)	1 (50)	1/0 (60)	1/0 (60)
150	3 (30)	3 (30)	2 (35)	1 (50)	1/0 (60)	2/0 (70)	3/0 (95)	3/0 (95)
200	3 (30)	2 (35)	1 (50)	1/0 (60)	2/0 (70)	3/0 (95)	4/0 (120)	4/0 (120)
250	2 (35)	1 (50)	1/0 (60)	2/0 (70)	3/0 (95)	4/0 (120)	2x2/0 (2x70)	2x2/0 (2x70)
300	1 (50)	1/0 (60)	2/0 (70)	3/0 (95)	4/0 (120)	2x2/0 (2x70)	2x3/0 (2x95)	2x3/0 (2x95)
350	1/0 (60)	2/0 (70)	3/0 (95)	4/0 (120)	2x2/0 (2x70)	2x3/0 (2x95)	2x3/0 (2x95)	2x4/0 (2x120)
400	1/0 (60)	2/0 (70)	3/0 (95)	4/0 (120)	2x2/0 (2x70)	2x3/0 (2x95)	2x4/0 (2x120)	2x4/0 (2x120)
500	2/0 (70)	3/0 (95)	4/0 (120)	2x2/0 (2x70)	2x3/0 (2x95)	2x4/0 (2x120)	3x3/0 (3x95)	3x3/0 (3x95)
600	3/0 (95)	4/0 (120)	2x2/0 (2x70)	2x3/0 (2x95)	2x4/0 (2x120)	3x3/0 (3x95)	3x4/0 (3x120)	3x4/0 (3x120)

* This chart is a general guideline and may not suit all applications. If cable overheats, use next size larger cable.

**Weld cable size (AWG) is based on either a 4 volts or less drop or a current density of at least 300 circular mils per ampere. () = mm² for metric use

***For distances longer than those shown in this guide, call a factory applications rep. at 920-735-4505 (Miller) or 1-800-332-3281 (Hobart).

Ref. S-0007-L 2015-02

5-3. Weld Output Terminals

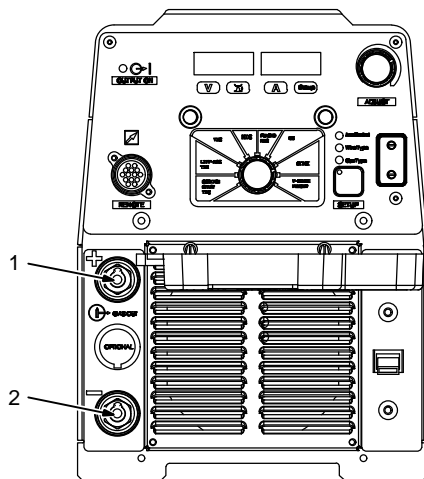

⚠ Turn off power before connecting to weld output terminals.

⚠ Do not use worn, damaged, undersized, or repaired cables.

- 1 Positive (+) Weld Output Terminal
- 2 Negative (-) Weld Output Terminal

☞ See Sections 7-1 thru 9-1 for standard connection diagrams.

Ref. 804 772-B / output term1 2015-02

5-4. Remote 14 Receptacle Information

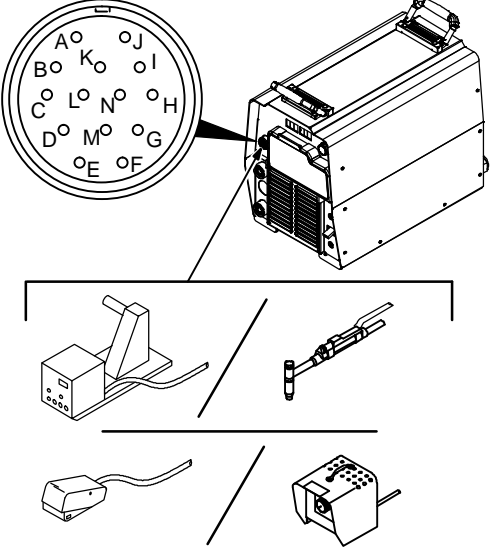
	REMOTE 14	Socket*	Socket Information
	24 VOLTS AC OUTPUT (CONTACTOR)	A	
B			Contact closure to A completes 24 volts AC contactor control circuit.
REMOTE OUTPUT CONTROL	C		Output to remote control; 0 to +10 volts DC, +10 volts DC in MIG mode.
	D		Remote control circuit common.
	E		0 to +10 volts DC input command signal from remote control.
	L		Wirefeed speed command, 0 to +10 volts DC output signal from wire feeder.
	M		CC/CV Select; 0 to +10 volts DC.
A/V AMPERAGE VOLTAGE	N		Wirefeed speed common.
	F		Current feedback; +1 volt DC per 100 amperes.
GND	H		Voltage feedback; +1 volt DC per 10 output receptacle volts.
	G		Circuit common for 24 volts AC circuits.
		K	Chassis common.

*The remaining sockets are not used.

5-5. Optional 115 Volts AC Duplex Receptacle And Supplementary Protectors

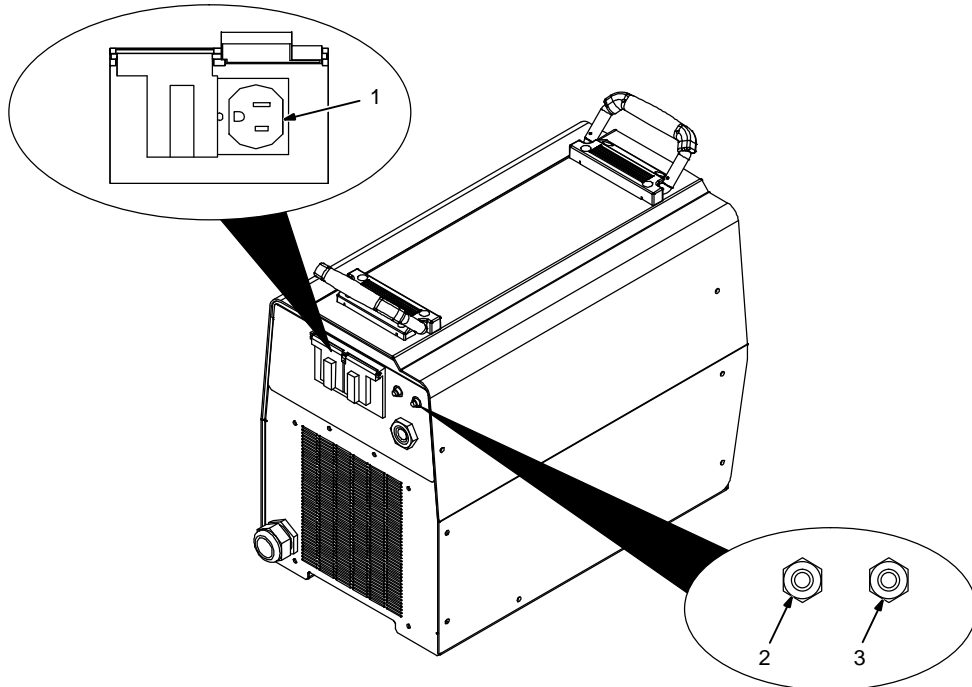

1 115 V 10 Amp AC Receptacle
 2 Supplementary Protector CB1
 3 Supplementary Protector CB2

CB1 protects duplex receptacle from overload.
 CB2 protects 24 volts AC portion of Remote 14 receptacle from overload.

Press button to supplementary protector.

803 691-D

5-6. Optional Gas Valve Operation And Shielding Gas Connection

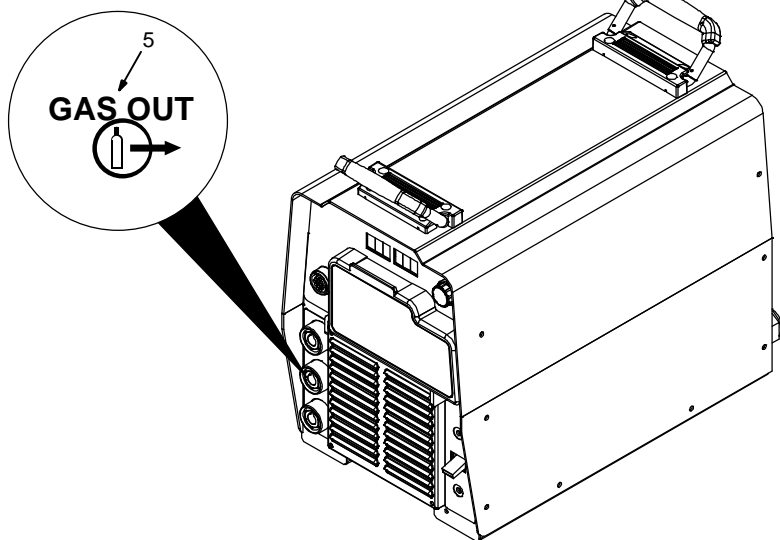
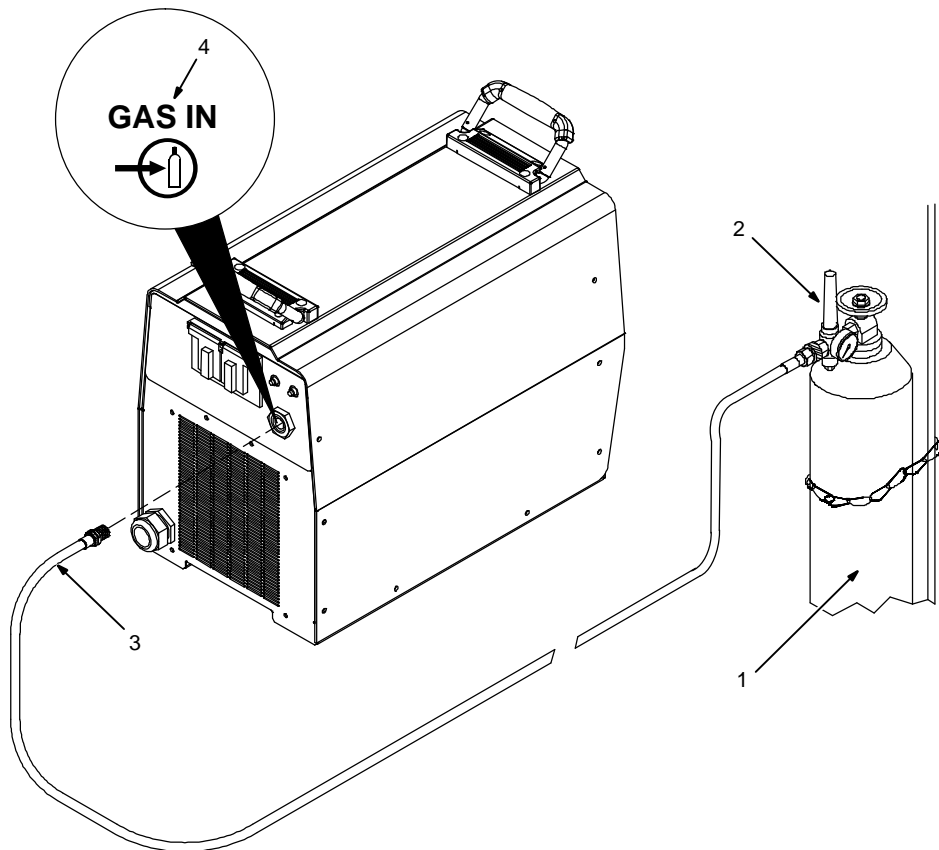

Obtain gas cylinder and chain to running gear, wall, or other stationary support so cylinder cannot fall and break off valve.

- 1 Cylinder
 - 2 Regulator/Flowmeter
- Install so face is vertical.
- 3 Gas Hose Connection

Fitting has 5/8-18 right-hand threads. Obtain and install gas hose.

- 4 Gas In Fitting
- 5 Gas Out Fitting

The Gas In and Gas Out fittings have 5/8-18 right-hand threads. Obtain proper size, type, and length hose and make connections as follows:

Connect hose from shielding gas supply regulator/flowmeter to Gas In fitting.

Connect hose coupler to torch. Connect one end of gas hose to hose coupler. Connect remaining end of gas hose to Gas Out fitting.

Operation

The gas solenoid controls gas flow during the TIG process as follows:

Remote TIG

Gas flow starts with remote contactor on.

Gas flow stops at end of post-flow if current was detected, or with remote contactor off if no current was detected.

Lift-Arc TIG

Gas flow starts when tungsten touches work (touch sensed).

Gas flow stops at end of post-flow.

Scratch Start TIG

Gas flow starts when current is detected.

Gas flow stops at end of post-flow.

Post-flow time is factory set to 5 seconds per 100 amps of weld current. The minimum post-flow time is 5 seconds. The maximum post-flow is 20 seconds (post flow settings are not adjustable by the end user).

5-7. Electrical Service Guide

Elec Serv 2014-01

NOTICE – INCORRECT INPUT POWER can damage this welding power source. Phase to ground voltage shall not exceed +10% of rated input voltage.

NOTICE – Actual input voltage should not be 10% less than minimum and/or 10% more than maximum input voltages listed in table. If actual input voltage is outside this range, output may not be available.

⚠ Failure to follow these electrical service guide recommendations could create an electric shock or fire hazard. These recommendations are for a dedicated circuit sized for the rated output and duty cycle of the welding power source.

In dedicated circuit installations, the National Electrical Code (NEC) allows the receptacle or conductor rating to be less than the rating of the circuit protection device. All components of the circuit must be physically compatible. See NEC articles 210.21, 630.11, and 630.12.

Input Voltage (V)	Single-Phase				
	208	230	400	460	575
Input Amperes (A) At Rated Output	60.8	54.6	29.7	25.4	19.9
Max Recommended Standard Fuse Rating In Amperes ¹					
Time-Delay Fuses ²	70	60	35	30	25
Normal Operating Fuses ³	80	80	45	40	30
Min Input Conductor Size In AWG/Kcmil ⁴	8	8	10	12	12
Max Recommended Input Conductor Length In Feet (Meters)	72 (22)	89 (27)	176 (54)	140 (43)	219 (67)
Min Grounding Conductor Size In AWG/Kcmil ⁴	8	8	10	12	12

Input Voltage (V)	Three-Phase				
	208	230	400	460	575
Input Amperes (A) At Rated Output	40.4	36.1	20.6	17.8	14.1
Max Recommended Standard Fuse Rating In Amperes ¹					
Time-Delay Fuses ²	45	40	25	20	15
Normal Operating Fuses ³	60	50	30	25	20
Min Input Conductor Size In AWG/Kcmil ⁴	8	10	12	14	14
Max Recommended Input Conductor Length In Feet (Meters)	119 (36)	96 (29)	175 (53)	150 (46)	234 (71)
Min Grounding Conductor Size In AWG/Kcmil ⁴	10	10	12	14	14

Reference: 2014 National Electrical Code (NEC) (including article 630)

1 If a circuit breaker is used in place of a fuse, choose a circuit breaker with time-current curves comparable to the recommended fuse.

2 "Time-Delay" fuses are UL class "RK5". See UL 248.

3 "Normal Operating" (general purpose - no intentional delay) fuses are UL class "K5" (up to and including 60 amps), and UL class "H" (65 amps and above).

4 Conductor data in this section specifies conductor size (excluding flexible cord or cable) between the panelboard and the equipment per NEC Table 310.15(B)(16). If a flexible cord or cable is used, minimum conductor size may increase. See NEC Table 400.5(A) for flexible cord and cable requirements.

5-8. Connecting 1-Phase Input Power

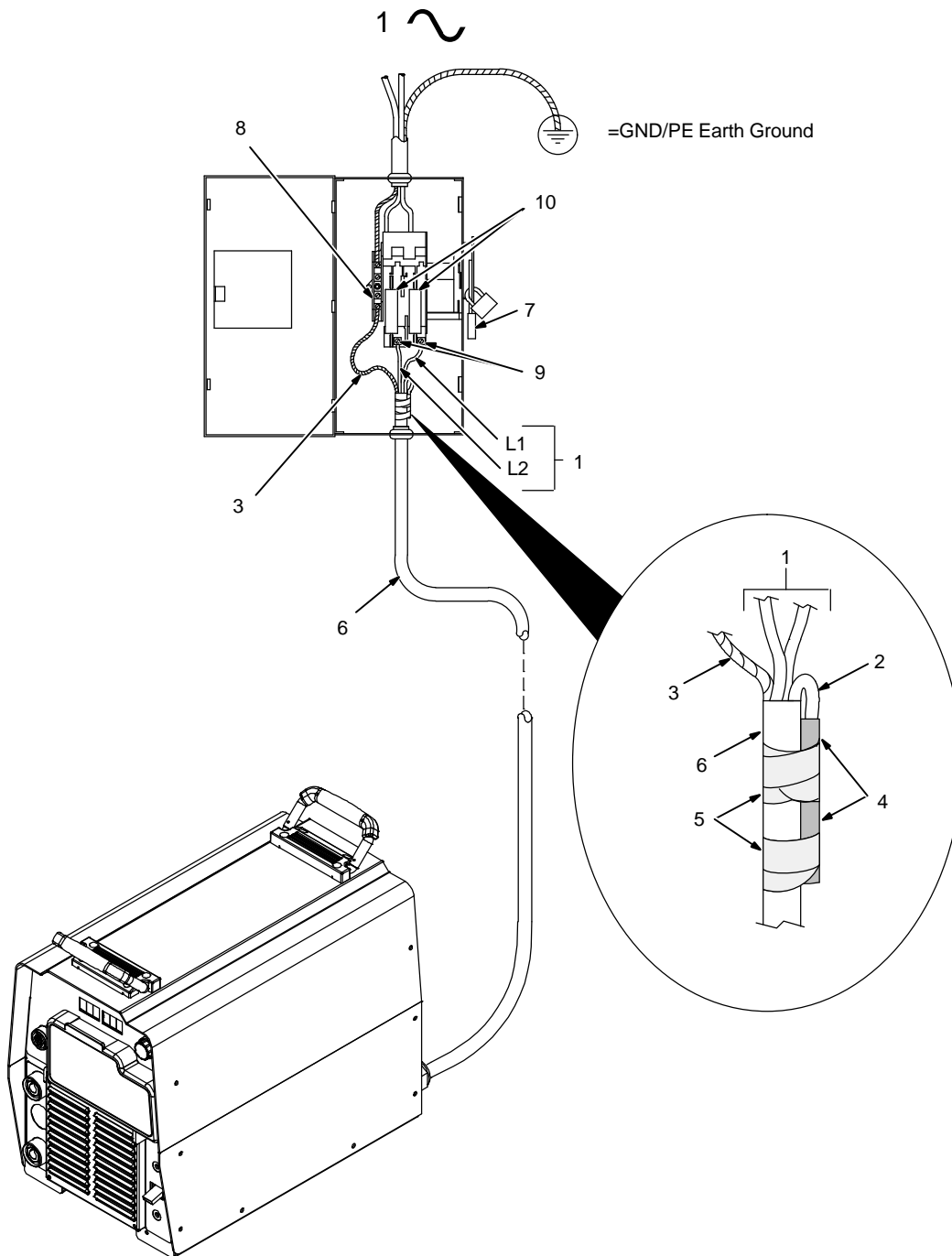

Tools Needed:



input1 2012-05 - Ref. 803 766-C

5-9. Connecting 3-Phase Input Power

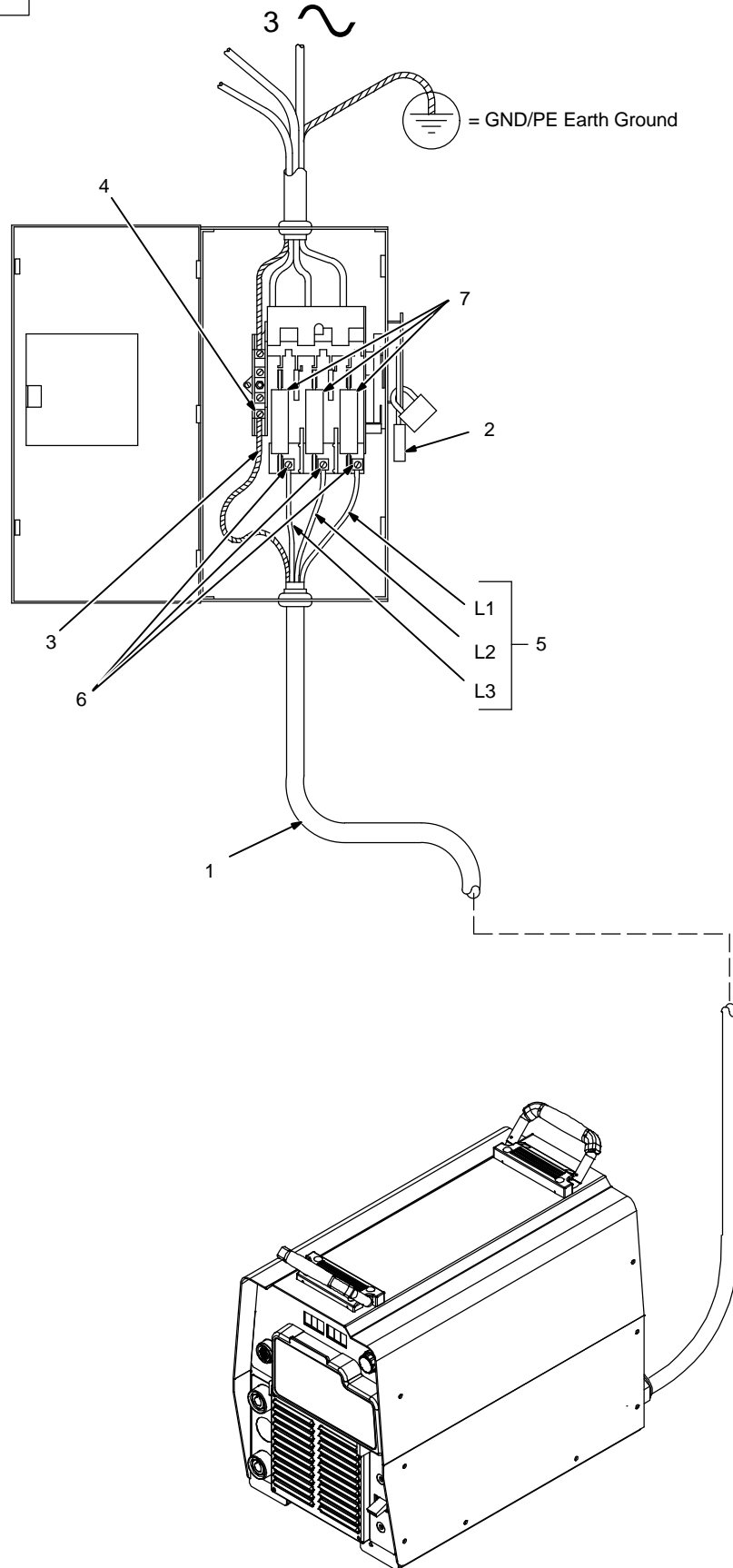

Tools Needed:

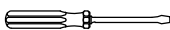

5-9. Connecting 3-Phase Input Power (Continued)



! Installation must meet all National and Local Codes – have only qualified persons make this installation.

! Disconnect and lockout/tagout input power before connecting input conductors from unit. Follow established procedures regarding the installation and removal of lockout/tagout devices.

! Always connect green or green/yellow conductor to supply grounding terminal first, and never to a line terminal.

NOTICE – The Auto-Line circuitry in this unit automatically adapts the power source to the primary voltage being applied. Check input

voltage available at site. This unit can be connected to any input power between 208 and 575 VAC without removing cover to relink the power source.

See rating label on unit and check input voltage available at site.

For Three-Phase Operation

- 1 Input Power Cord.
- 2 Disconnect Device (switch shown in the OFF position)
- 3 Green Or Green/Yellow Grounding Conductor
- 4 Disconnect Device Grounding Terminal

- 5 Input Conductors (L1, L2 And L3)

- 6 Disconnect Device Line Terminals

Connect green or green/yellow grounding conductor to disconnect device grounding terminal first.

Connect input conductors L1, L2, and L3 to disconnect device line terminals.

- 7 Over-Current Protection

Select type and size of over-current protection using Section 5-7 (fused disconnect switch shown).

Close and secure door on disconnect device. Follow established lockout/tagout procedures to put unit in service.

input2 2012-05

Notes



Work like a Pro!

Pros weld and cut safely. Read the safety rules at the beginning of this manual.

SECTION 6 – GENERAL OPERATION

6-1. Front Panel

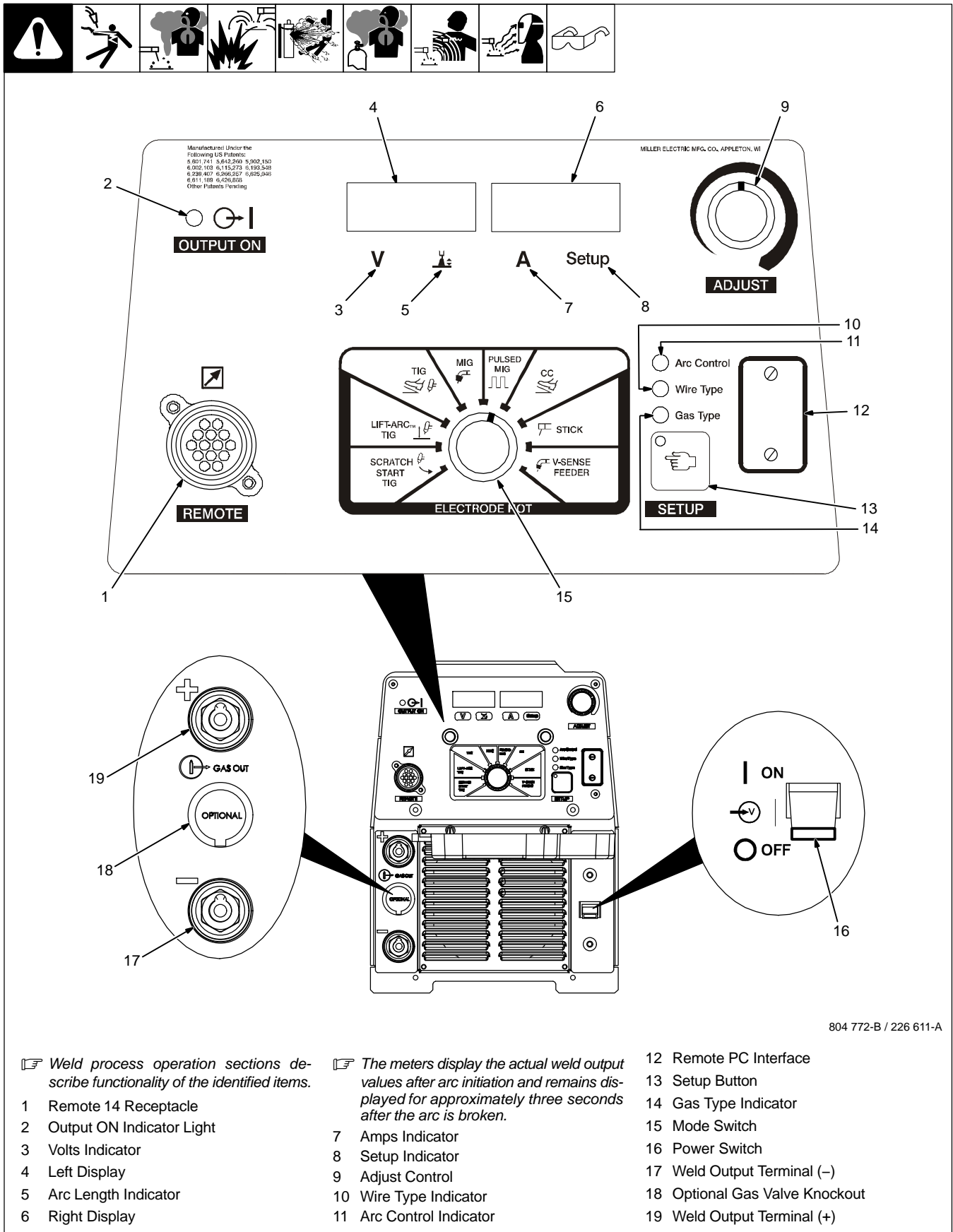

804 772-B / 226 611-A

Weld process operation sections describe functionality of the identified items.









- 1 Remote 14 Receptacle
- 2 Output ON Indicator Light
- 3 Volts Indicator
- 4 Left Display
- 5 Arc Length Indicator
- 6 Right Display

The meters display the actual weld output values after arc initiation and remains displayed for approximately three seconds after the arc is broken.

- 7 Amps Indicator
- 8 Setup Indicator
- 9 Adjust Control
- 10 Wire Type Indicator
- 11 Arc Control Indicator

- 12 Remote PC Interface
- 13 Setup Button
- 14 Gas Type Indicator
- 15 Mode Switch
- 16 Power Switch
- 17 Weld Output Terminal (-)
- 18 Optional Gas Valve Knockout
- 19 Weld Output Terminal (+)

6-2. Mode Switch Settings

Switch Position		Process	Output Control	Panel Adjust	Remote Adjust
	Scratch Start TIG	GTAW	Electrode Hot	Amps	% Panel Amps*
	Lift-Arc TIG	GTAW	Electrode Hot	Amps	% Panel Amps*
	TIG	GTAW	Remote 14	Amps	% Panel Amps
	MIG	GMAW	Remote 14	Volts	Volts
	Pulsed MIG	GMAW-P	Remote 14	Arc Length (0-100)*	Arc Length (0-100)*
	CC	SMAW CAC-A	Remote 14	Amps	% Panel Amps
	Stick	SMAW CAC-A	Electrode Hot	Amps	% Panel Amps*
	V-Sense Feeder	GMAW*	Electrode Hot	Volts	Volts

*See Configuration Option Menu (see Section 6-3) For adjustment alternatives.

Notes

6-3. Configuration Option Menu

Manufactured Under the Following US Patents:
 6,601,741 6,202,269 6,902,150
 6,002,103 6,115,273 6,113,548
 6,228,407 6,266,257 6,025,046
 6,811,108 6,426,880
 Other Patents Pending

MILLER ELECTRIC MFG. CO., APPLETON, WI

1 Mode Switch
 2 Remote 14 Receptacle
 3 Left Display
 4 Right Display
 5 Adjustment Control
 6 Remote PC Interface
 7 Setup Button

Setup

The Configuration Option Menu provides a means to customize some machine features for desired operation.

To enter the Configuration Option Menu, hold the Setup Button down during power up while the unit is displaying 8888 on the Left and

Right Displays. *SET-UP* will be displayed momentarily.

Configuration options are displayed in the Left Display. Settings are displayed in the Right Display. Settings can be changed by turning the Adjust Control. If a setting does not change when the Adjust Control is turned, the option is not configurable. Pressing the Setup Button moves to the next configuration option.

226 611-A

6-3 Configuration Option Menu (Continued)

V-Sense Feeder Weld Process

This option enables MIG (V.SEN MIG) or Pulsed MIG (V.SEN PULS) when the Mode Switch is in the VSENSE FEEDER position. See Section 8-2 for MIG operation or Section 8-4 for Pulsed MIG operation.

Pulsed MIG Manual/Auto Control

This option sets the PULSED MIG control as manual (*PULS MAN*) or Auto (*PULS AUTO*) operation. When set to manual operation, the arc length setting on power source and wire speed setting on wirefeeder need to be adjusted independently to achieve the desired arc length. When set to Auto operation, once arc length is determined it is not necessary to change the arc length value with changes in wirefeed speed.

The EXTREME 360 MAP and synergic feeders allow single knob control of the arc. As wirefeed speed is increased or decreased, the pulse parameters increase or decrease matching the power output to the wire speed.

☞ *Auto Operation will only work with synergic wirefeeders. All other wirefeeders will only operate as manual control. Even when Auto is displayed, operation will be manual when any other feeder is connected. See product literature for a list of compatible synergic feeders.*

6-3 Configuration Option Menu (Continued)

PULS

ARC.L

Pulsed MIG Adjustment

This option allows adjusting the Pulsed MIG process in units of Arc Length (*PULS ARC.L*) or preset voltage (*PULS VOLT*).

WFS

IPM

Wire Feed Speed And Wire Diameter Units

WFS IPM:

WFS is displayed in inches per minute
Diameter is displayed in inches

WFS MPM:

WFS is displayed in meters per minute
Diameter is displayed in millimeters

VRD

OFF

Voltage Reducing Device (VRD) Mode

This option enables (ON) or disables (OFF) low open circuit voltage (OCV) operation in Stick and Scratch Start TIG modes. See Section 9-4 for Low OCV Operation. When enabled, VRD ON is momentarily displayed after the power-on front panel LED test.

☞ If VRD -ON is displayed with a dash preceding ON, Low OCV Operation is enabled by hardware configuration and cannot be disabled in this menu.

PANL

RMT

Panel and Remote Adjustment

When the Mode Switch is set to SCRATCH START TIG, LIFT-ARC TIG, or STICK, the remote command behavior is configurable. SCRATCH START TIG and LIFT-ARC TIG default to panel and remote (PANL RMT) amperage adjustment but can be configured for panel only (PANL ONLY) adjustment. The default amperage adjustment for STICK is panel only (PANL ONLY) but can also be configured for panel and remote (PANL RMT) adjustment. All other Mode Switch positions are non-configurable and allow both panel and remote (PANL -RMT) adjustment.

☞ Panel adjustment is made using the Adjust Control on the front panel. Remote adjustment is made using a remote control device connected to the Remote 14 Receptacle.

INFO

NO

Revision Information

This option identifies the unit's weld library (*INFO LIB*) and firmware revision (*INFO REV*).

Press the Setup Button while the unit is displaying *INFO LIB* to identify the unit's weld library.

Press the Setup Button while the unit is displaying *INFO REV* to identify the unit's firmware revision.

Pressing the Setup Button while the unit is displaying *INFO NO* will move to the next configuration option.

EXIT

NO

Exit Configuration Option Menu

Press the Setup Button while the unit is displaying *EXIT NO* to return to the first configuration option. Press the Setup Button while the unit is displaying *EXIT YES* to exit the Configuration Option Menu.

☞ The Configuration Option Menu can be exited at any time by turning the unit off. Only if the unit is turned off after *EXIT NO* is displayed will configuration option changes be saved.

SECTION 7 – GTAW OPERATION

7-1. Typical Connection For GTAW Process

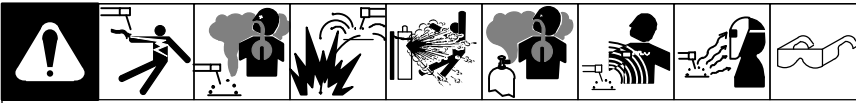

⚠ Turn off power before making connections.

- 1 Foot Control
- 2 Gas Out Connection (Optional)
- 3 Positive (+) Weld Output Terminal
- 4 Remote 14 Receptacle

Connect desired remote control to Remote 14 receptacle if required.

- 5 Gas In Connection (Optional)
- 6 Gas Cylinder
- 7 Negative (-) Weld Output Terminal
- 8 TIG Torch
- 9 Workpiece

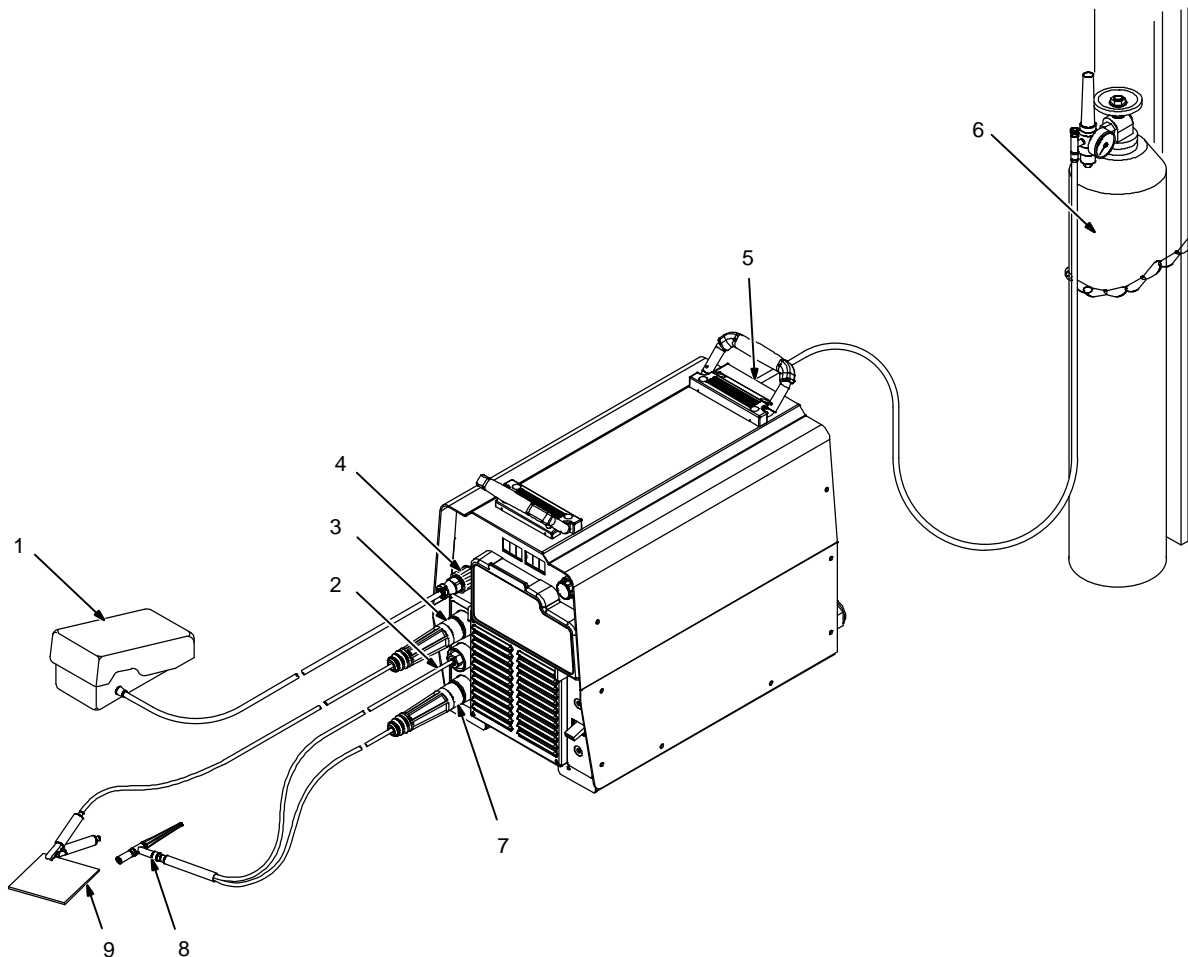

7-2. Scratch Start TIG Welding Mode - GTAW Process

Manufactured Under the Following US Patents:
 5,861,741 5,942,289 5,902,150
 6,022,103 6,115,273 6,193,248
 6,291,427 6,296,237 6,425,046
 6,611,189 6,426,888
 Other Patents Pending

MILLER ELECTRIC MFG. CO., APPLETON, WI

2 3 4 5 6

OUTPUT ON

V 72.0 A 85

ADJUST

REMOTE

ELECTRODE NOT

SETUP

○ Arc Control
 ○ Wire Type
 ○ Gas Type

1

226 611-A

⚠ Weld terminals are energized at all times in Scratch Start TIG welding mode.

- 1 Mode Switch
- 2 Volts Indicator
- 3 Left Display
- 4 Right Display
- 5 Amps Indicator
- 6 Adjust Control

Setup

For typical system connections refer to Section 7-1.

Rotate Mode Switch to SCRATCH START TIG position as shown.

The open circuit voltage is shown in the Left Display with the Volts Indicator lit. Preset amperage is shown in the Right Display with the Amps Indicator lit.

Operation

The Adjust Control is used to set desired preset amperage.

ℹ If a remote control is used for amperage adjustment, the adjustment will function as a percentage of the preset amperage.

ℹ For best results, gently scratch the tungsten electrode to the work to initiate an arc. To minimize arc flare at the end of the weld, pull back the electrode quickly to extinguish the arc.

7-3. Lift-Arc TIG Welding Mode - GTAW Process

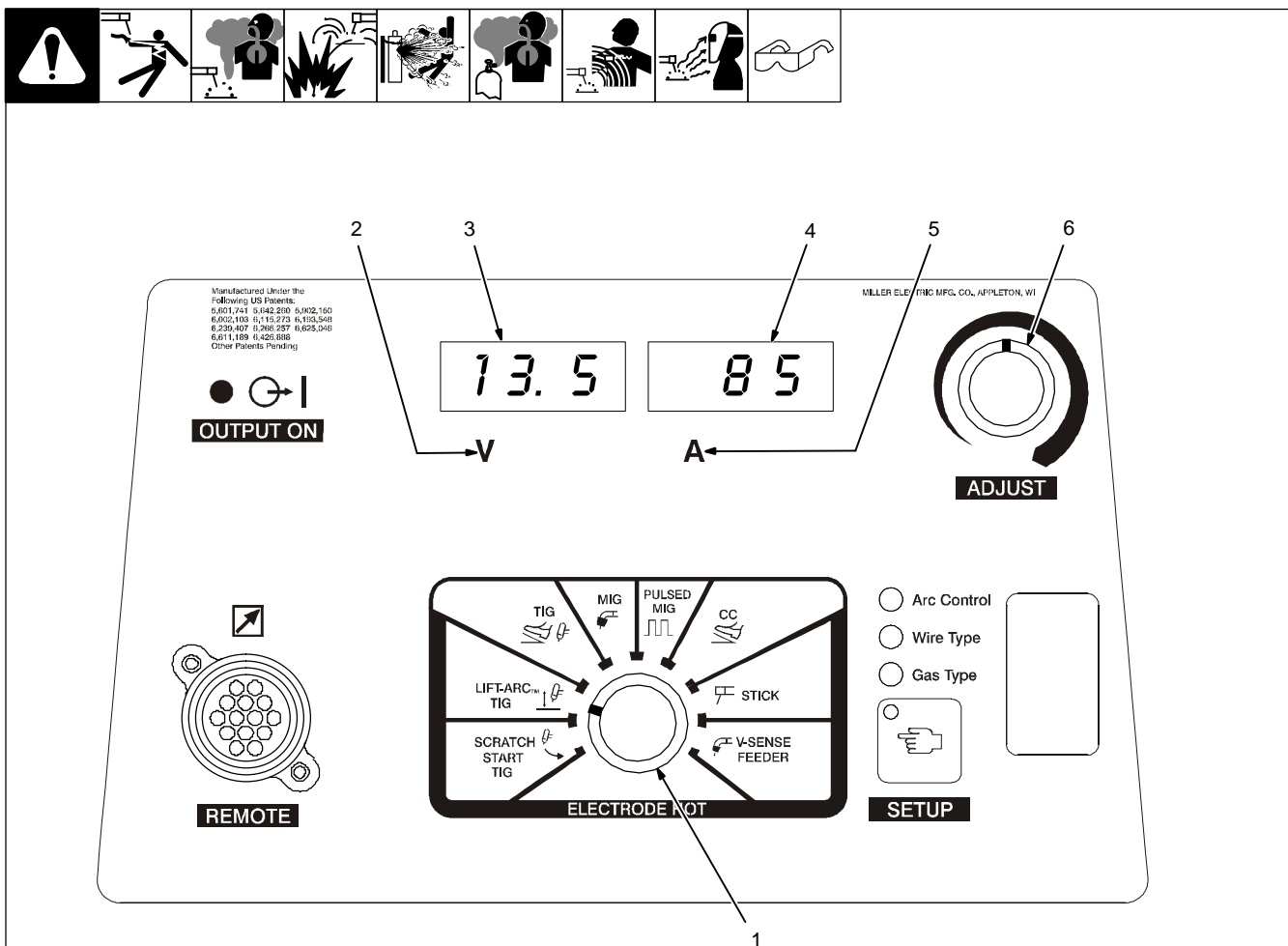

226 611-A

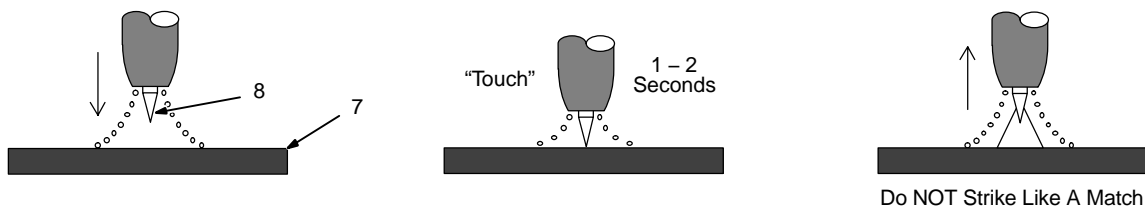

⚠ Weld terminals are energized at all times in Lift Arc TIG welding mode.

- 1 Mode Switch
- 2 Volts Indicator
- 3 Left Display
- 4 Right Display
- 5 Amps Indicator
- 6 Adjust Control
- 7 Workpiece
- 8 Tungsten Electrode

Setup

For typical system connections refer to Section 7-1.

Rotate Mode Switch to LIFT-ARC TIG position as shown.

The open-circuit voltage is shown in the Left Display with the Volts Indicator lit. Preset amperage is shown in the Right Display with the Amps Indicator lit.

Normal open-circuit voltage is not present before the electrode touches the workpiece, instead a low sensing voltage is present. The sensing voltage allows the electrode to touch the workpiece without overheating, sticking, or getting contaminated.

Operation

The Adjust Control is used to set desired preset amperage.

ℳ If a remote control is used for amperage adjustment, the adjustment will function as a percentage of the preset amperage.

ℳ For best results, firmly touch the tungsten electrode to the workpiece at the weld start point. Hold electrode to workpiece for 1-2 seconds, and lift electrode. An arc will form when the electrode is lifted. To minimize arc flare at the end of the weld, pull back the electrode quickly to extinguish the arc.

7-4. TIG Welding Mode - GTAW Process

Manufactured Under the Following US Patents:
 5,001,731 5,162,266 5,902,150
 6,002,103 6,115,273 6,193,548
 6,228,407 6,261,237 6,623,048
 6,611,189 6,426,988
 Other Patents Pending

OUTPUT ON

ADJUST

REMOTE

SETUP

ELECTRODE NOT

ARC CONTROL

WIRE TYPE

GAS TYPE

TIG

MIG

PULSED MIG

CC

STICK

V-SENSE FEEDER

LIFT-ARC TIG

SCRATCH START TIG

85

A

1

2

3

4

5

226 611-A

⚠ Weld terminals are energized through the remote control in TIG welding mode.

- 1 Mode Switch
- 2 Left Display
- 3 Right Display
- 4 Amps Indicator
- 5 Adjust Control

Setup

For typical system connections refer to Section 7-1.

Rotate Mode Switch to TIG position as shown.

The preset amperage is shown in the Right Display with the Amps Indicator lit.

Operation

The Adjust Control is used to set desired preset amperage.

A remote control is required to turn on the weld output.

ℹ If the remote control has an amperage adjustment, the adjustment will function as a percentage of the preset amperage.

ℹ For best results, gently scratch the tungsten electrode to the work to initiate an arc. To minimize arc flare at the end of the weld, pull back the electrode quickly to extinguish the arc.

SECTION 8 – GMAW/GMAW-P/FCAW OPERATION

8-1. Typical Connection For Remote Control Feeder GMAW/GMAW-P/FCAW Process

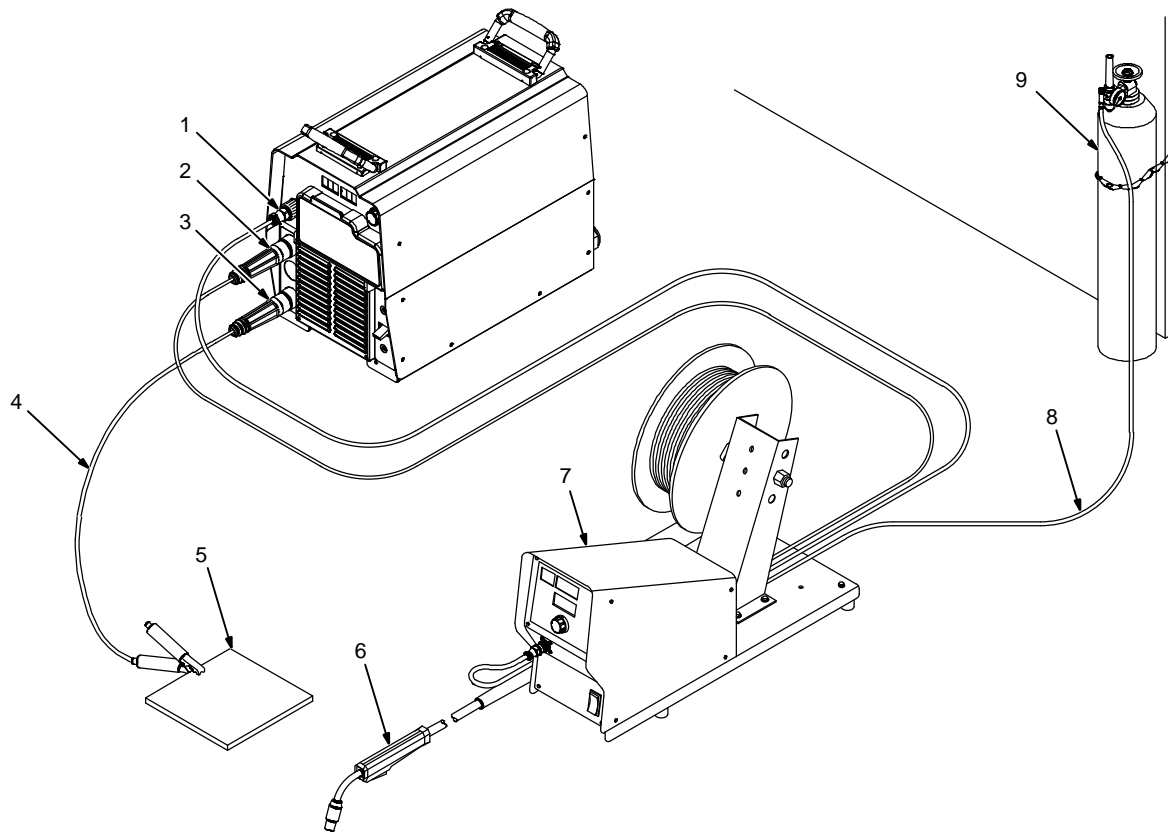
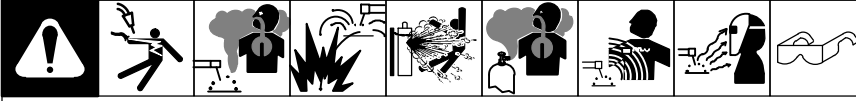

804 938-A

⚠ Turn off power before making connections.

- 1 Remote 14-Receptacle
- 2 Positive (+) Weld Output Terminal
- 3 Negative (-) Weld Output Terminal
- 4 Ground Cable to Workpiece

- 5 Workpiece
- 6 Gun
- 7 Wire Feeder
- 8 Gas Hose
- 9 Gas Cylinder

Use of shielding gas is dependant on Wire Type.

☞ The connection diagram illustrates DCEP (reverse polarity) suitable for all wires except self-shielded FCAW. The majority of self-shielded FCAW wires require DCEN (straight polarity).

8-2. MIG Welding Mode - GMAW/FCAW Process

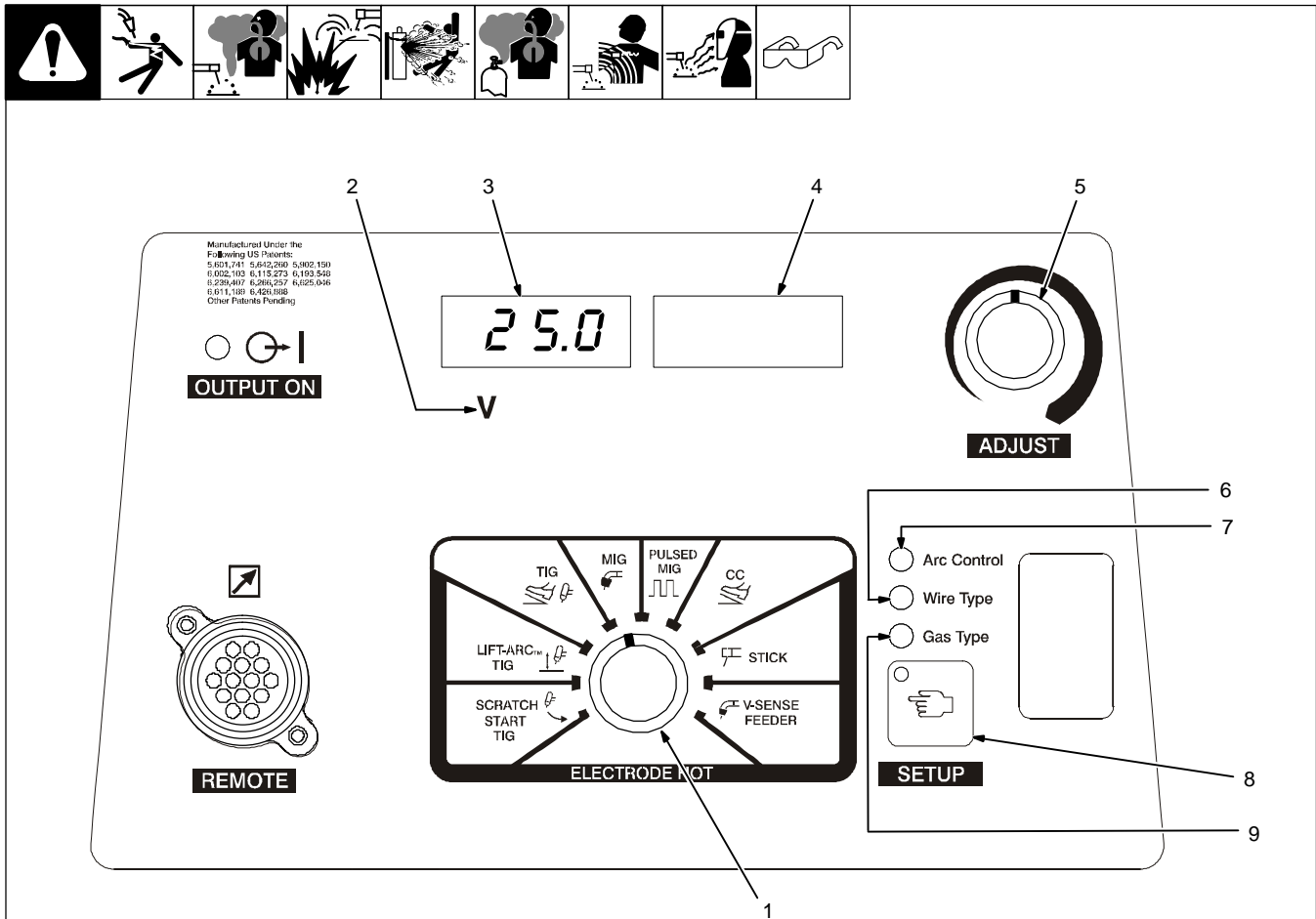

226 611-A

⚠ Weld terminals are energized through the remote control in MIG welding mode.

- 1 Mode Switch
- 2 Volts Indicator
- 3 Left Display
- 4 Right Display
- 5 Adjust Control
- 6 Wire Type Indicator
- 7 Arc Control Indicator
- 8 Setup Button
- 9 Gas Type Indicator

Setup

For typical system connections refer to Section 8-1.

Rotate Mode Switch to MIG position as shown.

The preset voltage is shown in the Left Display with the Volts Indicator lit.

Operation

While the Volts Indicator is lit under the Left Display, the Adjust Control is used to set desired preset voltage.

☞ The preset voltage can be adjusted remotely at the wire feeder if the feeder has a voltage control. This voltage control will override the Adjust Control of preset voltage on the welding power source.

Pressing the Setup Button allows adjustment of Arc Control, Wire Type, Gas Type and preset voltage.

☞ For best results, select the appropriate Wire and Gas Type to match the actual wire and gas being used. Refer to the MIG – Wire and Gas Selection Table for available wires and gases (see Section 8-3).

Selecting a Wire and Gas

Press the Setup Button repeatedly until the Wire Type indicator is lit. The active Wire Type will appear in the Left and Right Display.

Rotate Adjust Control to select desired wire.

Press the Setup Button again so the Gas Type indicator is lit. The active Gas Type will appear in the Left and Right Display.

Rotate Adjust Control to select desired gas.

Press the Setup Button to confirm the selection. The unit will acknowledge a change of wire and gas information by displaying PROG LOAD momentarily.

Arc Control (Inductance)

Press the Setup Button repeatedly until the Arc Control indicator is lit. *INDU* appears on the Left Display, and the corresponding inductance setting appears on the Right Display.

Rotate Adjust Control to select desired inductance setting from 0 to 100. Use lower inductance settings to stiffen the arc and reduce puddle fluidity. Use higher inductance settings to soften the arc and increase puddle fluidity.

Refer to the MIG – Wire and Gas Selection Table (see Section 8-3) for suggested inductance setting for the specific wire and gas being used.

Press the Setup Button to return to adjustment of preset voltage.

☞ Each Wire and Gas Type combination has independent preset voltage and inductance settings. These settings are preserved when the unit is turned off.

8-3. MIG - Wire and Gas Selection Table

WIRE TYPES**		GAS TYPES	DEFAULT INDUCTANCE
Steel	.035 (0.9) STL .045 (1.2) STL .052 (1.4) STL	ARGN CO2 (ARGON / CARBON DIOXIDE) ARGN OXY (ARGON / OXYGEN)	30
	.035 (0.9) STL .045 (1.2) STL	CO2 (CARBON DIOXIDE)	10
Flux Core	.035 (0.9) FCAW .045 (1.2) FCAW .052 (1.4) FCAW 1/16 (1.6) FCAW	ARGN CO2 (ARGON / CARBON DIOXIDE) * CO2 (CARBON DIOXIDE)	30 *
Metal Core	.045 (1.2) MCOR .052 (1.4) MCOR 1/16 (1.6) MCOR	ARGN CO2 (ARGON / CARBON DIOXIDE)	30
Stainless Steel	.035 (0.9) SSTL .045 (1.2) SSTL	TRI MIX (TRI-GAS MIXTURE) ARGN OXY (ARGON / OXYGEN)	70
Aluminum	.035 (0.9) AL4X (4000 Series) .040 (1.0) AL4X (4000 Series) 3/64 (1.2) AL4X (4000 Series) 1/16 (1.6) AL4X (4000 Series)	ARGN (ARGON)	10
	.035 (0.9) AL5X (5000 Series) .040 (1.0) AL5X (5000 Series) 3/64 (1.2) AL5X (5000 Series) 1/16 (1.6) AL5X (5000 Series)		

*For self-shielded FCAW wires use the ARGN CO2 gas selection and set inductance to less than 10.

**Wire diameter in inches (mm). Refer to section 6-3 to change displayed units.

Notes

8-4. Pulsed MIG Welding Mode - GMAW-P Process

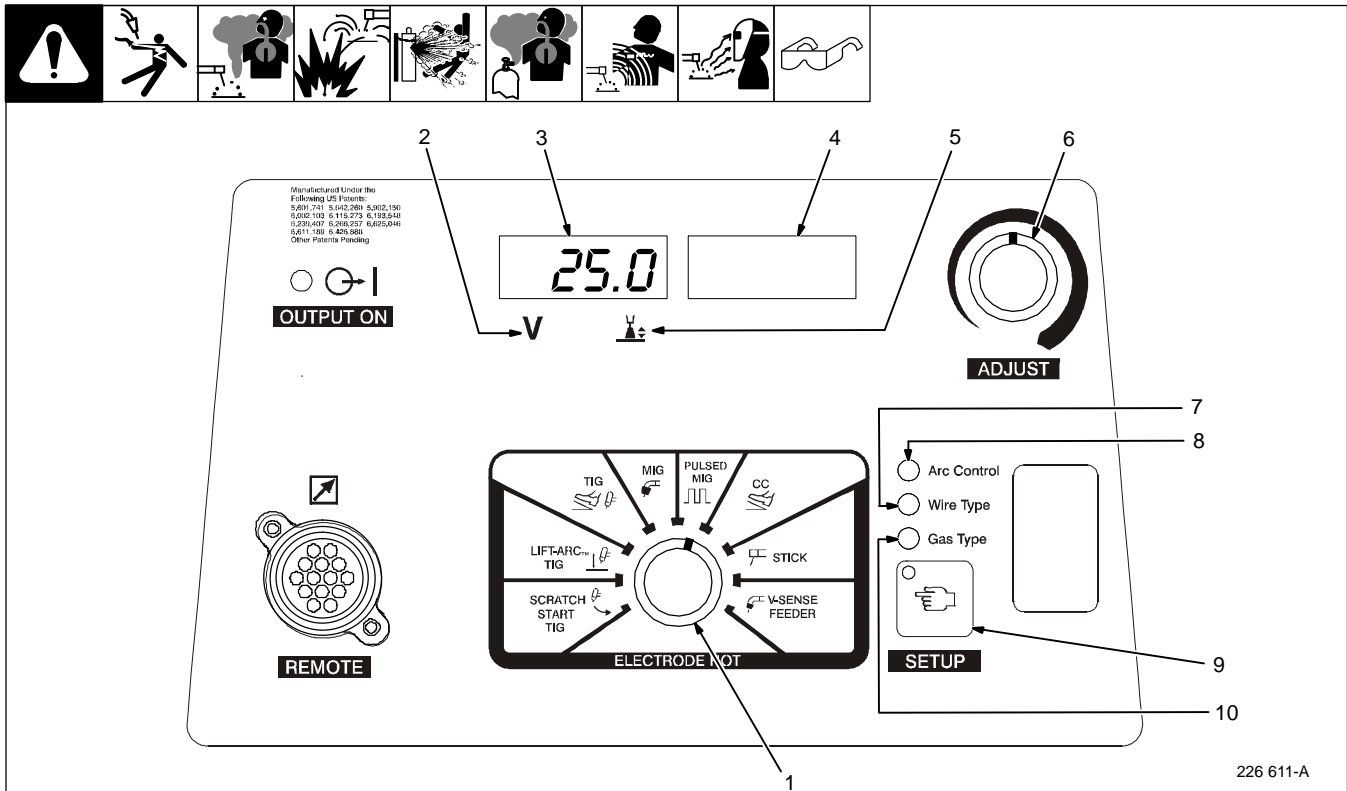

226 611-A

⚠ Weld terminals are energized through the remote control in Pulsed MIG welding mode.

- 1 Mode Switch
- 2 Volts Indicator
- 3 Left Display
- 4 Right Display
- 5 Arc Length Indicator
- 6 Adjust Control
- 7 Wire Type Indicator
- 8 Arc Control Indicator
- 9 Setup Button
- 10 Gas Type Indicator

Setup

For typical system connections refer to Section 8-1.

Rotate Mode Switch to PULSED MIG position as shown.

The trim setting is shown in the Left Display with the Arc Length Indicator lit.

Operation

While the Arc Length Indicator is lit under the Left Display, the Adjust Control is used to set desired trim setting.

ℒ The trim can be adjusted remotely at the wire feeder if the feeder has a voltage control. This voltage control will override the Adjust Control of trim on the welding power source.

Pressing the Setup Button allows adjustment of Arc Control, Wire Type, Gas Type and Arc Length.

ℒ For best results, select the appropriate Wire and Gas Type to match the actual wire and gas being used. Refer to

Pulsed MIG - Wire and Gas Selection Table for available wires and gases (see Section 8-5).

Selecting a Wire and Gas

Press the Setup Button repeatedly until the Wire Type indicator is lit. The active Wire Type will appear in the Left and Right Display.

Rotate Adjust Control to select desired wire.

Press the Setup Button again so the Gas Type indicator is lit. The active Gas Type will appear in the Left and Right Display.

Rotate Adjust Control to select desired gas.

Press the Setup Button again to confirm the selection. The unit will acknowledge a change of wire and gas information by displaying *PROG LOAD* momentarily.

Arc Control (SharpArc)

Press the Setup Button repeatedly until the Arc Control indicator is lit. *SHRP* appears on the Left Display, and the corresponding SharpArc setting appears on the Right Display.

Rotate Adjust Control to select desired SharpArc setting from 0 to 50, default is 25. Adjusting the SharpArc setting changes the welding arc cone. Lower settings widen the arc cone, increases puddle fluidity and flattens the weld bead appearance.

Higher settings narrow the arc cone, reduces puddle fluidity and crowns the weld bead appearance.

ℒ Each Wire and Gas Type combination has independent Arc Length and SharpArc settings. These settings are preserved when the unit is turned off.

Arc Length - Pulsed MIG Manual Control (see Section 6-3)

Arc length corresponds to the level of energy needed to burn off the welding electrode. As wire feed speed increases, a higher arc length setting is required to burn off the additional wire. The arc length setting appears in the Left Display when the Arc Length Indicator is lit. Arc length can be adjusted from 0 to 100.

After the welding output terminals are energized, but prior to arc initiation, the unit displays the letter "R" and a reference wire speed (IPM) on the Right Display. The reference wire speed can be used as a starting point for the wire speed setting at the feeder. The wire speed and arc length setting can then be further adjusted to achieve the desired arc length.

The Configuration Option Menu (see Section 6-1) can be used to change the arc length setting (0 to 100) to average arc voltage. Average arc voltage can be used as an alternative method to set the Pulsed MIG welding arc with the same parameters (voltage and wire speed) as a conventional MIG arc. Lower voltage settings correspond to tighter arc lengths while higher voltage settings correspond to longer arc lengths. If the voltage mode is selected, the average voltage preset will be displayed on the Left Display with the Volts Indicator lit.

Arc Length - Pulsed MIG Auto Control (see Section 6-3)

In Auto operation the arc length setting is 0-100. The programs have been developed at 50 arc length setting. Increasing or decreasing the arc length setting from 50 will change the arc length. It is not necessary to change the arc length value when changing wire feed speed settings.

8-5. Pulsed MIG - Wire and Gas Selection Table

WIRE TYPES*		GAS TYPES
Steel	.035 (0.9) STL .045 (1.2) STL	ARGN CO2 (ARGON / CARBON DIOXIDE) 80 ARGN CO2 (ARGON / CARBON DIOXIDE) ARGN OXY (ARGON / OXYGEN)
Steel 100S	.035 (0.9) STL .045 (1.2) STL	100S C5 (95 ARGON / 5 CARBON DIOXIDE)
Metal Core	.045 (1.2) MCOR .052 (1.4) MCOR	ARGN CO2 (ARGON / CARBON DIOXIDE)
Stainless Steel	.035 (0.9) SSSL .045 (1.2) SSSL	TRI MIX (TRI-GAS MIXTURE) ARGN OXY (ARGON / OXYGEN) ARGN CO2 (ARGON / CARBON DIOXIDE)
Aluminum	.035 (0.9) AL4X (4000 Series) .040 (1.0) AL4X (4000 Series) 3/64 (1.2) AL4X (4000 Series) 1/16 (1.6) AL4X (4000 Series)	ARGN (ARGON)
	.035 (0.9) AL49 (4943) .040 (1.0) AL49 (4943) 3/64 (1.2) AL49 (4943) 1/16 (1.6) AL49 (4943)	
	.035 (0.9) AL5X (5000 Series) .040 (1.0) AL5X (5000 Series) 3/64 (1.2) AL5X (5000 Series) 1/16 (1.6) AL5X (5000 Series)	ARGN (ARGON) HE AR25 (HELIUM/ARGON)
Nickel	.035 (0.9) NI .045 (1.2) NI	ARGN HE (ARGON / HELIUM) ARGN (ARGON)
Copper Nickel	.035 (0.9) CUNI .045 (1.2) CUNI	HE ARGN (HELIUM / ARGON)
Silicon Bronze	.035 (0.9) SIBR .045 (1.2) SIBR	ARGN (ARGON)
Titanium	.035 (0.9) TI-5 .045 (1.2) TI-5	ARGN HE25 (75 ARGON / 25 HELIUM)
	.035 (0.9) TI-5 .045 (1.2) TI-5	ARGN HE50 (50 ARGON / 50 HELIUM)
*Wire diameter in inches (mm). Refer to section 6-3 to change displayed units.		

☞ Other normal gas mixtures can be used by adjusting arc length and sharp arc. Use the program closest to your gas mixture and wire type and size.

Notes

8-6. Remote Process Select

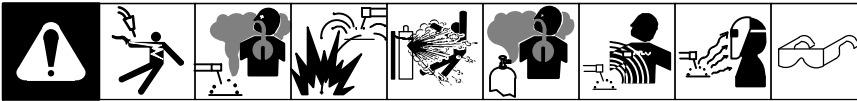

This power source can be used with wire feeders that support Remote Process Select. This feature allows the operator to switch the active welding process between MIG and Pulsed MIG at the wire feeder. To determine if the welding system is Remote Process Select capable, connect the wire feeder to the power source and review the power source display variations shown below.

When used with an XMT power source, the Process Select knob must be set to Pulsed MIG for Remote Process Select to be active.



Power Source Display – Wire Feeder with Remote Process Select Not Detected

When the power source Right Display is blank, a wire feeder with Remote Process Select is not detected. Set the active weld process at the power source.



Power Source Display – Wire Feeder with Remote Process Select Detected

When the power source Right Display is MIG, a wire feeder with Remote Process Select is detected and set for MIG operation. The active weld process can **only** be changed at the wire feeder.



Power Source Display – Wire Feeder with Remote Process Select Detected and Set for Pulsed MIG

When the power source Right Display is PULS, a Remote Process Select wire feeder is detected and is set for Pulsed MIG operation. The active weld process can **only** be changed at the wire feeder.

Using a Dual Wire Feeder with Remote Process Select

When using a dual wire feeder with Remote Process Select, different weld programs for the left and right side can be selected. The power source MIG and Pulsed MIG programs for the left side of wire feeder are selected with the left side of the wire feeder active. The power source MIG and Pulsed MIG programs for the right side are selected with the right side of the wire feeder active. When the right side of the wire feeder is active, the power source Right Display will show a decimal point in the lower right hand corner as shown.

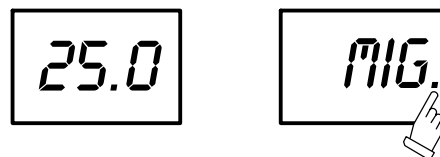

Decimal point indicates wire feeder right side is active.

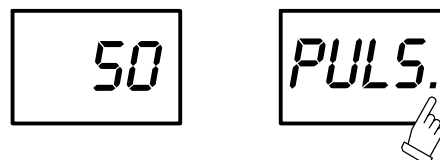

Decimal point indicates wire feeder right side is active.

Power Source Display – Dual Wire Feeder with Right Side Active and Set for MIG

Power Source Display – Dual Wire Feeder with Right Side Active and Set for Pulsed MIG

8-7. Typical Connection For Voltage-Sensing Feeder GMAW/GMAW-P/FCAW Process

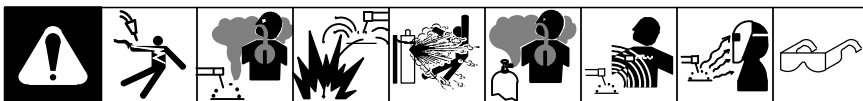

⚠ Turn off power before making connections.

- 1 Positive (+) Weld Output Terminal
- 2 Negative (-) Weld Output Terminal
- 3 Ground Cable to Workpiece
- 4 Workpiece
- 5 Voltage Sensing Clamp
- 6 Gun
- 7 Gun Trigger Receptacle
- 8 Wire Feeder
- 9 Gas Hose
- 10 Gas Cylinder

Use of shielding gas is dependant on Wire Type.

☞ The connection diagram illustrates DCEP (reverse polarity) suitable for all wires except self-shielded FCAW. The majority of self-shielded FCAW wires require DCEN (straight polarity).

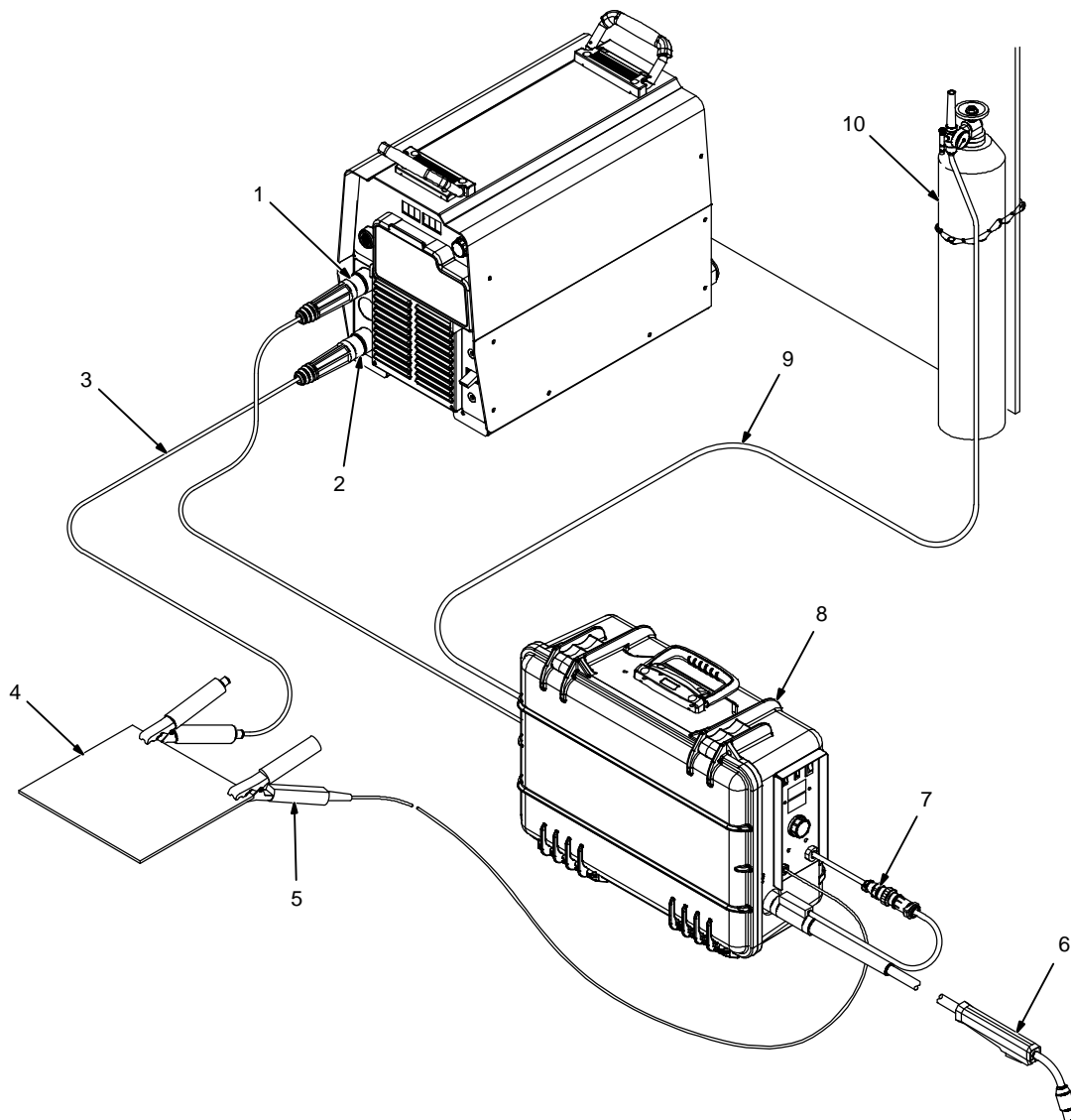

804 843-B

8-8. V-Sense Feeder Welding Mode - GMAW/FCAW Process

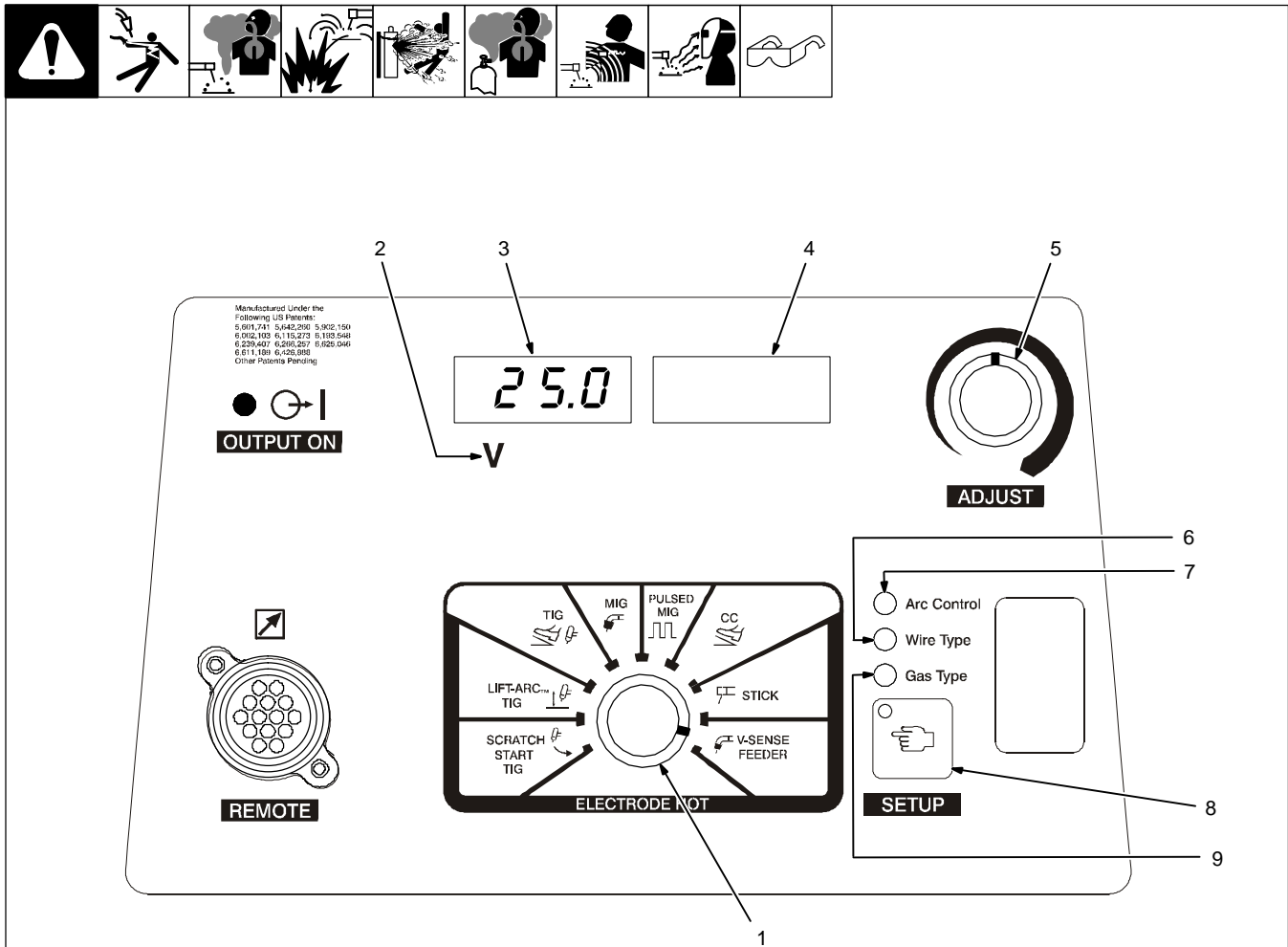

226 611-A

⚠ Weld terminals are energized at all times in V-Sense Feeder welding mode.

- 1 Mode Switch
- 2 Volts Indicator
- 3 Left Display
- 4 Right Display
- 5 Adjust Control
- 6 Wire Type Indicator
- 7 Arc Control Indicator
- 8 Setup Button
- 9 Gas Type Indicator

Setup

For typical system setup connections refer to Section 8-7.

Rotate Mode Switch to V-SENSE FEEDER position as shown.

The Left Display toggles between open circuit voltage and preset voltage with the Volts Indicator lit.

Operation

While the Volts Indicator is lit under the Left Display, the Adjust Control is used to set desired preset voltage.

☞ The Left Display toggling momentarily pauses while the preset voltage is adjusted.

Pressing the Setup Button allows adjustment of Arc Control, Wire Type, Gas Type and preset voltage.

☞ For best results, select the appropriate Wire and Gas Type to match the actual wire and gas being used.

Refer to MIG – Wire and Gas Selection Table for available wires and gases (see Section 8-3).

Selecting a Wire and Gas

Press the Setup Button repeatedly until the Wire Type indicator is lit. The active Wire Type will appear in the Left and Right Display.

Rotate Adjust Control to select desired wire.

Press the Setup Button again so the Gas Type indicator is lit. The active Gas Type will appear in the Left and Right Display.

Rotate Adjust Control to select desired gas.

Press the Setup Button again to confirm the selection. The unit will acknowledge a change of wire and gas information by displaying *PROG LOAD* momentarily.

Arc Control (Inductance)

Press the Setup Button repeatedly until the Arc Control indicator is lit. *INDU* appears on the Left Display, and the corresponding inductance setting appears on the Right Display.

Rotate Adjust Control to select desired inductance setting from 0 to 100. Use lower inductance settings to stiffen the arc and reduce puddle fluidity. Use higher inductance settings to soften the arc and increase puddle fluidity.

Refer to the MIG – Wire and Gas Selection Table (see Section 8-3) for suggested inductance setting for the specific wire and gas being used.

☞ Each Wire and Gas Type combination has independent preset voltage and inductance settings. These settings are preserved when the unit is turned off.

8-9. V-Sense Feeder Welding Mode - GMAW-P Process

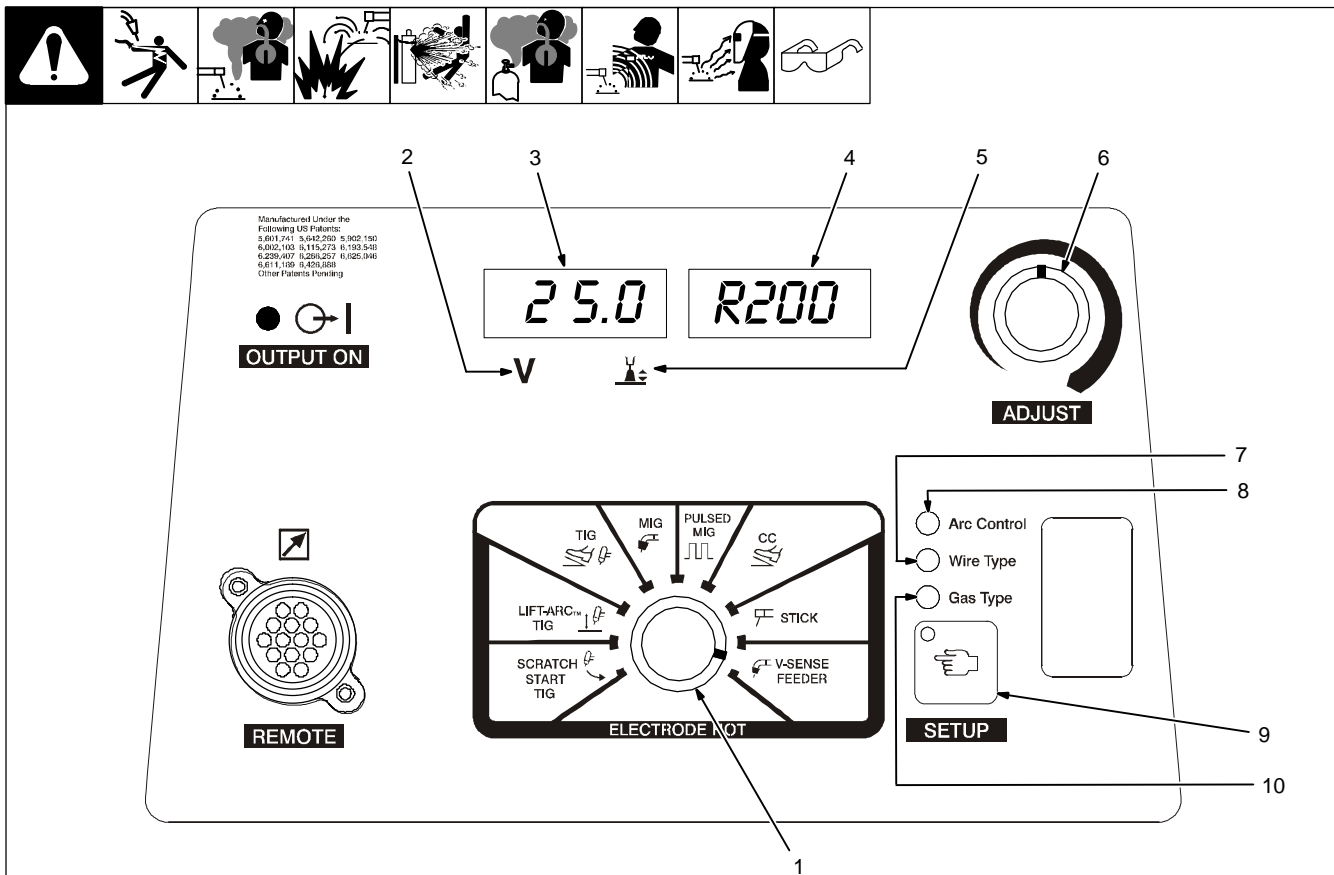

226 611-A

⚠ Weld terminals are energized at all times in V-Sense Feeder welding mode.

- 1 Mode Switch
- 2 Volts Indicator
- 3 Left Display
- 4 Right Display
- 5 Arc Length Indicator
- 6 Adjust Control
- 7 Wire Type Indicator
- 8 Arc Control Indicator
- 9 Setup Button
- 10 Gas Type Indicator

Setup

For typical system setup connections refer to Section 8-7.

Rotate Mode Switch to V-SENSE FEEDER position as shown.

The Left Display toggles between open circuit voltage and the trim setting. The open circuit voltage is shown while the Volts Indicator is lit, and the trim setting is shown while the Arc Length Indicator is lit.

Operation

While the Arc Length Indicator is lit under the Left Display, the Adjust Control is used to set desired trim setting.

☞ The Left Display toggling momentarily pauses while the trim setting is adjusted.

Pressing the Setup Button allows adjust-

ment of Arc Control, Wire Type, Gas Type and Arc Length.

☞ For best results, select the appropriate Wire and Gas Type to match the actual wire and gas being used.

Refer to Pulsed MIG – Wire and Gas Selection Table for available wires and gases (see Section 8-5).

Selecting a Wire and Gas

Press the Setup Button repeatedly until the Wire Type indicator is lit. The active Wire Type will appear in the Left and Right Display.

Rotate Adjust Control to select desired wire.

Press the Setup Button again so the Gas Type indicator is lit. The active Gas Type will appear in the Left and Right Display.

Rotate Adjust Control to select desired gas.

Press the Setup Button again to confirm the selection. The unit will acknowledge a change of wire and gas information by displaying *PROG LOAD* momentarily.

Arc Control (SharpArc)

Press the Setup Button repeatedly until the Arc Control indicator is lit. *SHRP* appears on the Left Display, and the corresponding SharpArc setting appears on the Right Display.

Rotate Adjust Control to select desired SharpArc setting from 0 to 50, default is 25. Adjusting the SharpArc setting changes the welding arc cone. Lower settings widen the arc cone, increases puddle fluidity and flattens the weld bead appearance.

Higher settings narrow the arc cone, reduces puddle fluidity and crowns the weld bead appearance.

☞ Each Wire and Gas Type combination has independent Arc Length and SharpArc settings. These settings are preserved when the unit is turned off.

Arc Length (Trim)

Trim corresponds to the level of energy needed to burn off the welding electrode. As wire feed speed increases, a higher trim setting is required to burn off the additional wire. The trim setting appears in the Left Display when the Arc Length Indicator is lit. Trim can be adjusted from 0 to 100.

Prior to arc initiation, the unit displays the letter "R" and a reference wire speed (IPM) on the Right Display. The reference wire speed can be used as a starting point for the wire speed setting at the feeder. The wire speed and trim can then be further adjusted to achieve the desired arc length.

The Configuration Option Menu (see Section 6-3) can be used to change the Arc Length setting from trim (0 to 100) to average arc voltage. Average arc voltage can be used as an alternative method to set the Pulsed MIG welding arc with the same parameters (voltage and wire speed) as a conventional MIG arc. Lower voltage settings correspond to tighter arc lengths while higher voltage settings correspond to longer arc lengths. If the voltage mode is selected, the average preset voltage will be displayed on the Left Display with the Volts Indicator lit.

SECTION 9 – SMAW/CAC-A OPERATION

9-1. Typical Connection For SMAW And CAC-A Process

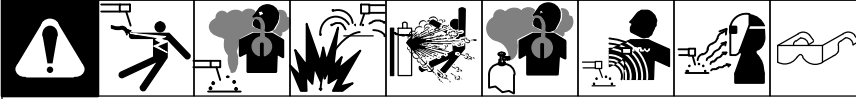

⚠ Turn off power before making connections.

1 Electrode Holder (Carbon Arc)

For CAC-A process connect carbon arc cutting torch to positive weld output terminal.

2 Electrode Holder

3 Positive (+) Weld Output Terminal

4 Remote 14 Receptacle

Connect desired remote control to remote 14 receptacle as required.

5 Compressed Air Line

6 Negative (-) Weld Output Terminal

7 Workpiece

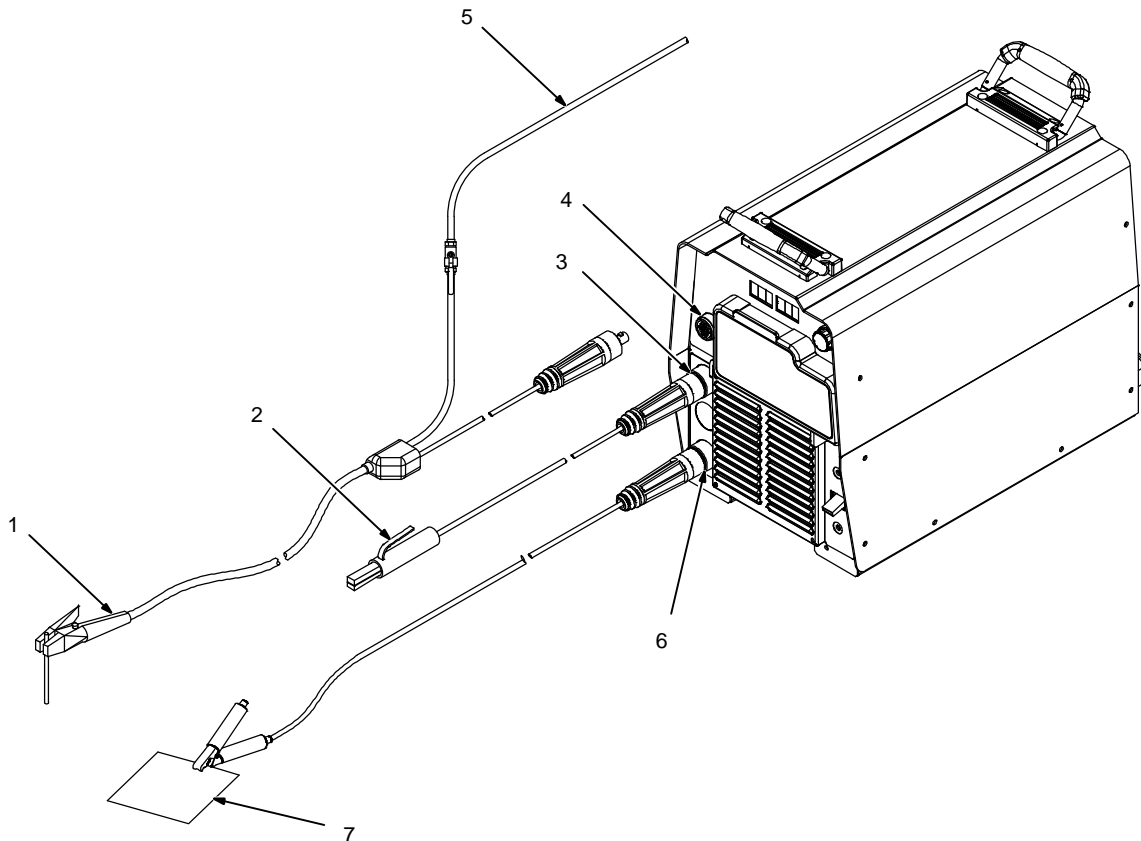

9-2. CC Welding Mode - SMAW/CAC-A Process

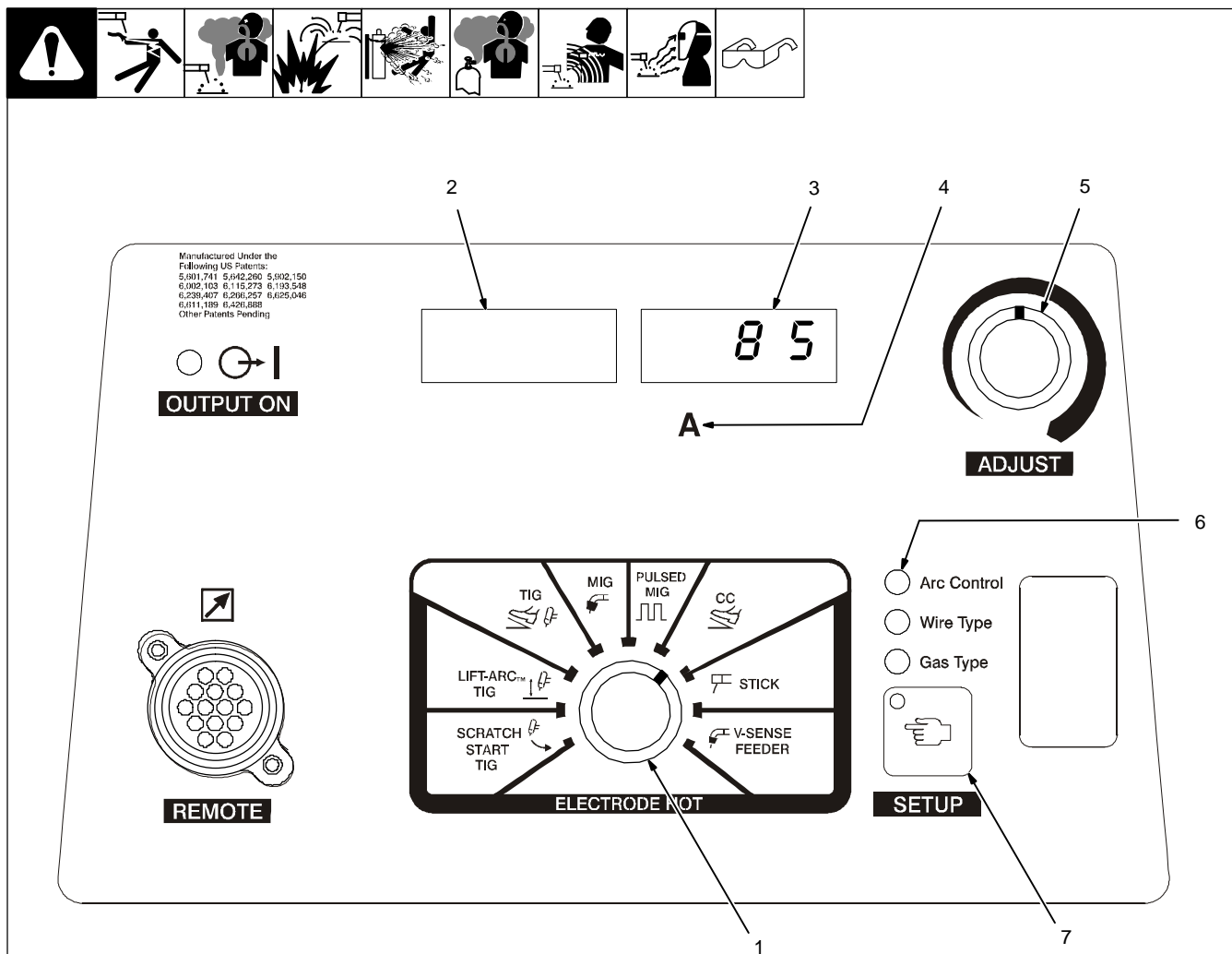

226 611-A

⚠ Weld terminals are energized through the remote control in CC welding mode.

- 1 Mode Switch
- 2 Left Display
- 3 Right Display
- 4 Amps Indicator
- 5 Adjust Control
- 6 Arc Control Indicator
- 7 Setup Button

Setup

For typical system connections refer to Section 9-1.

Rotate Mode Switch to CC position as shown.

The preset amperage is shown in the Right Display with the Amps Indicator lit.

Operation

While the Amps Indicator is lit under the Right Display, the Adjust Control is used to set desired preset amperage.

A remote control is required to turn on the weld output.

☞ If the remote control has an amperage adjustment, the adjustment will function as a percentage of the preset amperage.

Pressing the Setup Button allows adjustment of Arc Control, Hot Start Current and Hot Start Time.

☞ For best results at the end of the weld, pull back the electrode quickly to extinguish the arc.

Arc Control (Dig)

Press the Setup Button so the Arc Control indicator is lit. *DIG* appears on the Left Display, and the corresponding dig setting appears on the Right Display.

Rotate Adjust Control to select desired dig setting from 0 to 100.

Dig control allows the arc characteristics, soft versus stiff, to be changed for specific applications and electrodes. Lower the dig setting for smooth running electrodes like E7018 and increase the dig setting for stiffer, more penetrating electrodes like E6010.

Press the Setup Button repeatedly until the Arc Control light goes out to return to adjustment of preset amperage.

Programmable Hot Start

Press the Setup button repeatedly until *HOT.S* appears on the Left Display. *HOT.S* adjusts the Hot Start Amperage to Adaptive Hot Start (AUTO) or from Min (1) to Max (50). Adaptive Hot Start (AUTO) automatically chooses a default amperage. The Min (1) setting results in no hot start amperage. Higher numbers result in higher start amperage.

Press the Setup button again so *HOT.T* appears on the Left Display. *HOT.T* adjusts the Hot Start Time to Adaptive Hot Start (AUTO) or from Min (1) to Max (50). Adaptive Hot Start (AUTO) automatically chooses a default Time. The Min (1) setting results in no hot start time. Higher numbers result in longer start time.

Press the Setup Button to return to adjustment of preset amperage.

☞ Use this mode for Air Carbon Arc (CAC-A) cutting and gouging. For best results, adjust dig setting to maximum.

9-3. Stick Welding Mode - SMAW/CAC-A Process

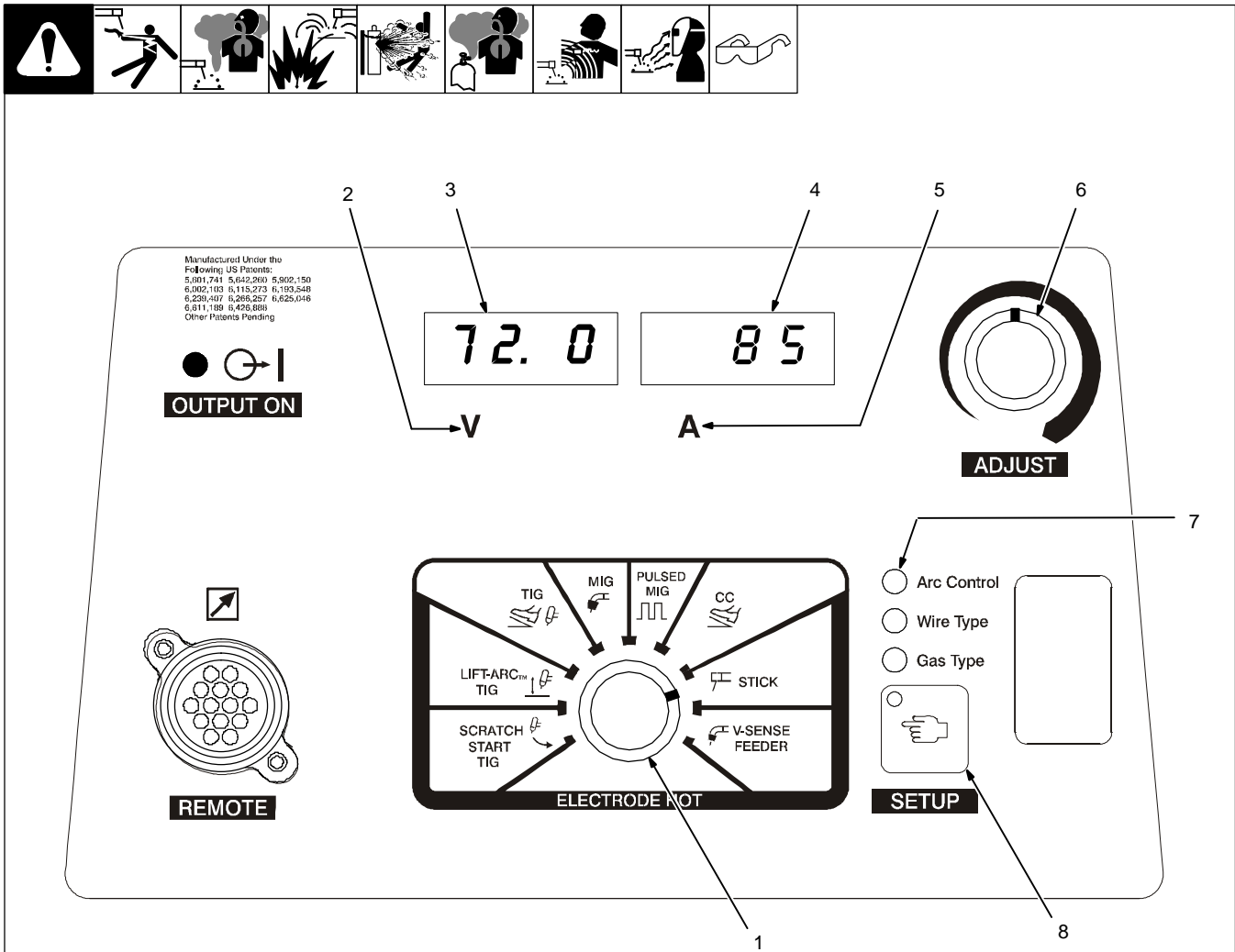

226 611-A

⚠ Weld terminals are energized at all times in Stick welding mode.

- 1 Mode Switch
- 2 Volts Indicator
- 3 Left Display
- 4 Right Display
- 5 Amps Indicator
- 6 Adjust Control
- 7 Arc Control Indicator
- 8 Setup Button

Setup

For typical system connections refer to Section 9-1.

Rotate Mode Switch to STICK position as shown.

The open circuit voltage is shown in the Left Display with the Volts Indicator lit, and the preset amperage is shown in the Right Display with the Amps Indicator lit.

Operation

While the Amps Indicator is lit under the

Right Display, the Adjust Control is used to set desired preset amperage.

Pressing the Setup Button allows adjustment of Arc Control, Hot Start Current and Hot Start Time.

☞ For best results at the end of the weld, pull back the electrode quickly to extinguish the arc.

Arc Control (Dig)

Press the Setup Button so the Arc Control indicator is lit. DIG appears on the Left Display, and the corresponding dig setting appears on the Right Display.

Rotate Adjust Control to select desired dig setting from 0 to 100.

Dig control allows the arc characteristics, soft versus stiff, to be changed for specific applications and electrodes. Lower the dig setting for smooth running electrodes like E7018 and increase the dig setting for stiffer, more penetrating electrodes like E6010.

Press the Setup Button repeatedly until the Arc Control light goes out to return to adjustment of preset amperage.

Programmable Hot Start

Press the Setup button repeatedly until HOT.S appears on the Left Display. HOT.S adjusts the Hot Start Amperage to Adaptive Hot Start (AUTO) or from Min (1) to Max (50). Adaptive Hot Start (AUTO) automatically chooses a default amperage. The Min (1) setting results in no hot start amperage. Higher numbers result in higher start amperage.

Press the Setup button again so HOT.T appears on the Left Display. HOT.T adjusts the Hot Start Time to Adaptive Hot Start (AUTO) or from Min (1) to Max (50). Adaptive Hot Start (AUTO) automatically chooses a default Time. The Min (1) setting results in no hot start time. Higher numbers result in longer start time.

☞ Use this mode for Air Carbon Arc (CAC-A) cutting and gouging. For best results, adjust dig setting to maximum.

SECTION 10 – MAINTENANCE & TROUBLESHOOTING

10-1. Routine Maintenance

		Maintain more often during severe conditions.	
✓ = Check ◇ = Change ● = Clean ☆ = Replace			
Every 3 Months	Replace Damaged Or Unreadable Labels		Replace Cracked Torch Body
	Repair Or Replace Cracked Cables		
	Repair Or Replace Cracked Cables And Cords		
	Clean And Tighten Weld Connections		
Every 6 Months	Blow Out Inside		

10-2. Blowing Out Inside Of Unit

⚠ Do not remove case when blowing out inside of unit.

To blow out unit, direct airflow through front and back louvers as shown.

Ref. 803 691-D

10-3. Help Displays

☞ All directions are in reference to the front of the unit. All circuitry referred to is located inside the unit.

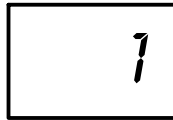

Help 1 Display

Indicates a malfunction in the primary power circuit. If this display is shown, contact a Factory Authorized Service Agent.



Help 2 Display

Indicates a malfunction in the thermal protection circuitry. If this display is shown, contact a Factory Authorized Service Agent.

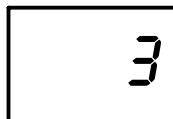

Help 3 Display

Indicates the left side of the unit has overheated. The unit has shut down to allow the fan to cool it (see Section 4-6). Operation will continue when the unit has cooled.



Help 5 Display

Indicates the right side of the unit has overheated. The unit has shut down to allow the fan to cool it (see Section 4-6). Operation will continue when the unit has cooled.



Help 6 Display

Indicates operation at maximum input current. The unit has a maximum allowable input current limit. As the line voltage decreases, the required input current increases. If the line voltage is too low, the output power is limited by the input current. When this limit is reached, the unit automatically reduces output power to continue operation. If this display is shown, have a qualified electrician check the input voltage.

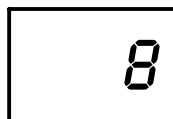

Help 8 Display

Indicates a malfunction in the secondary power circuit of the unit. If this display is shown, contact a Factory Authorized Service Agent.



Help 25 Display

Indicates machine has reached duty cycle limits (see Section 4-6). Unit must be left on to power the fan for cooling. Operation will continue when unit has cooled.

10-4. Troubleshooting

Trouble		Remedy		
No weld output; unit completely inoperative.	Place line disconnect switch in On position (see Sections 5-8 and 5-9).			
	Check and replace line fuse(s), if necessary, or reset circuit breaker (see Sections 5-8 and 5-9).			
	Check for proper input power connections (see Sections 5-8 and 5-9).			
No weld output; meter display On.	Input voltage outside acceptable range of variation (see Section 5-7).			
	Check, repair, or replace remote control.			
	Unit overheated. Allow unit to cool with fan On (see Section 4-6).			
Erratic or improper weld output.	Use proper size and type of weld cable (see Section 5-2).			
	Clean and tighten all weld connections.			
	Check for correct polarity.			
No 115 volts AC output at optional duplex receptacle.	Reset supplementary protector CB1 (see Section 5-5).			
No 24 volts AC output at Remote 14 receptacle.	Reset supplementary protector CB2 (see Section 5-5).			

Notes

Notes

Lined area for notes, consisting of multiple horizontal lines.

SECTION 11 – ELECTRICAL DIAGRAM

 ELECTRIC SHOCK HAZARD	WARNING
	<ul style="list-style-type: none"> • Do not touch live electrical parts. • Disconnect input power or stop engine before servicing. • Do not operate with covers removed. • Have only qualified persons install, use, or service this unit.

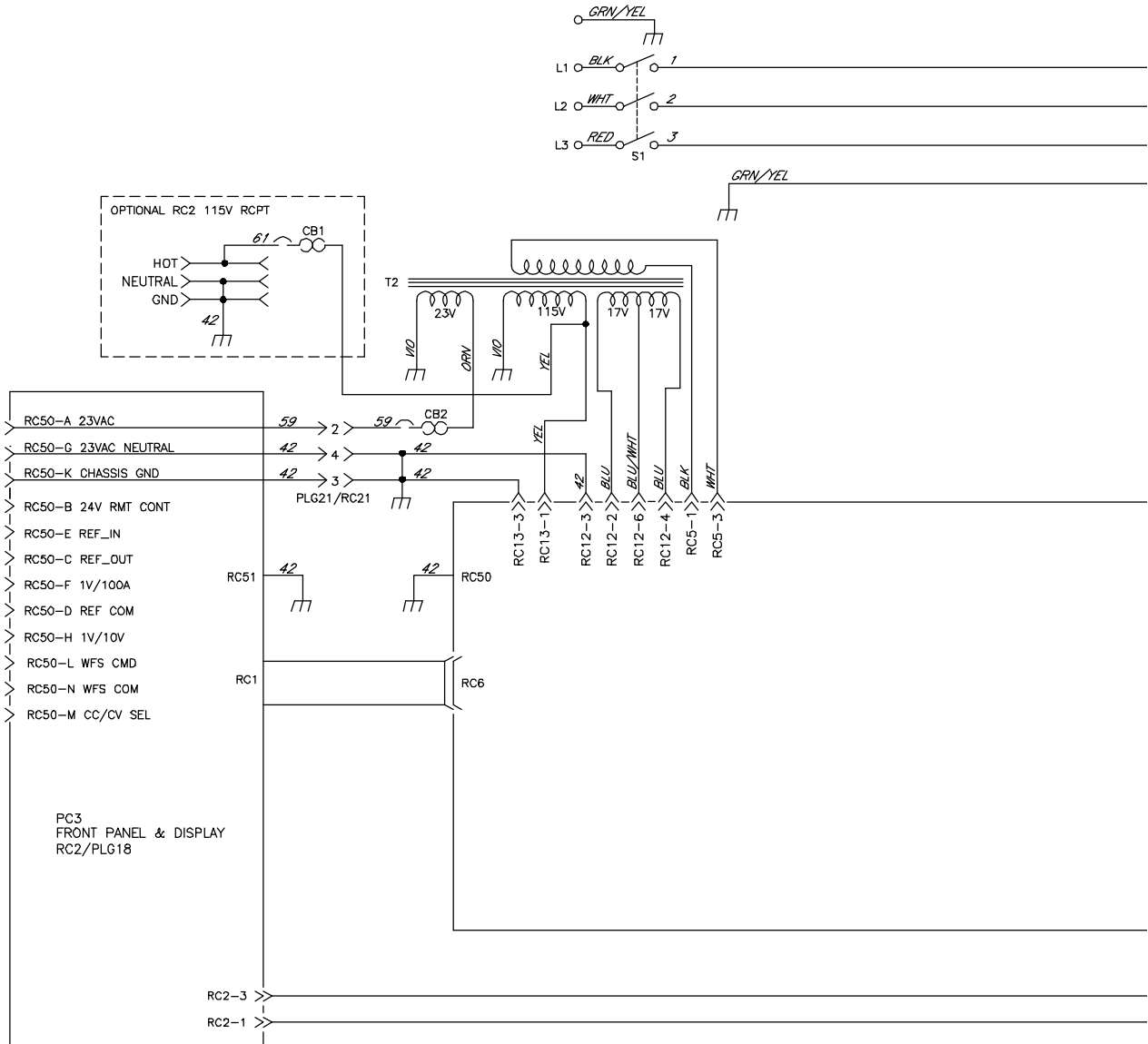
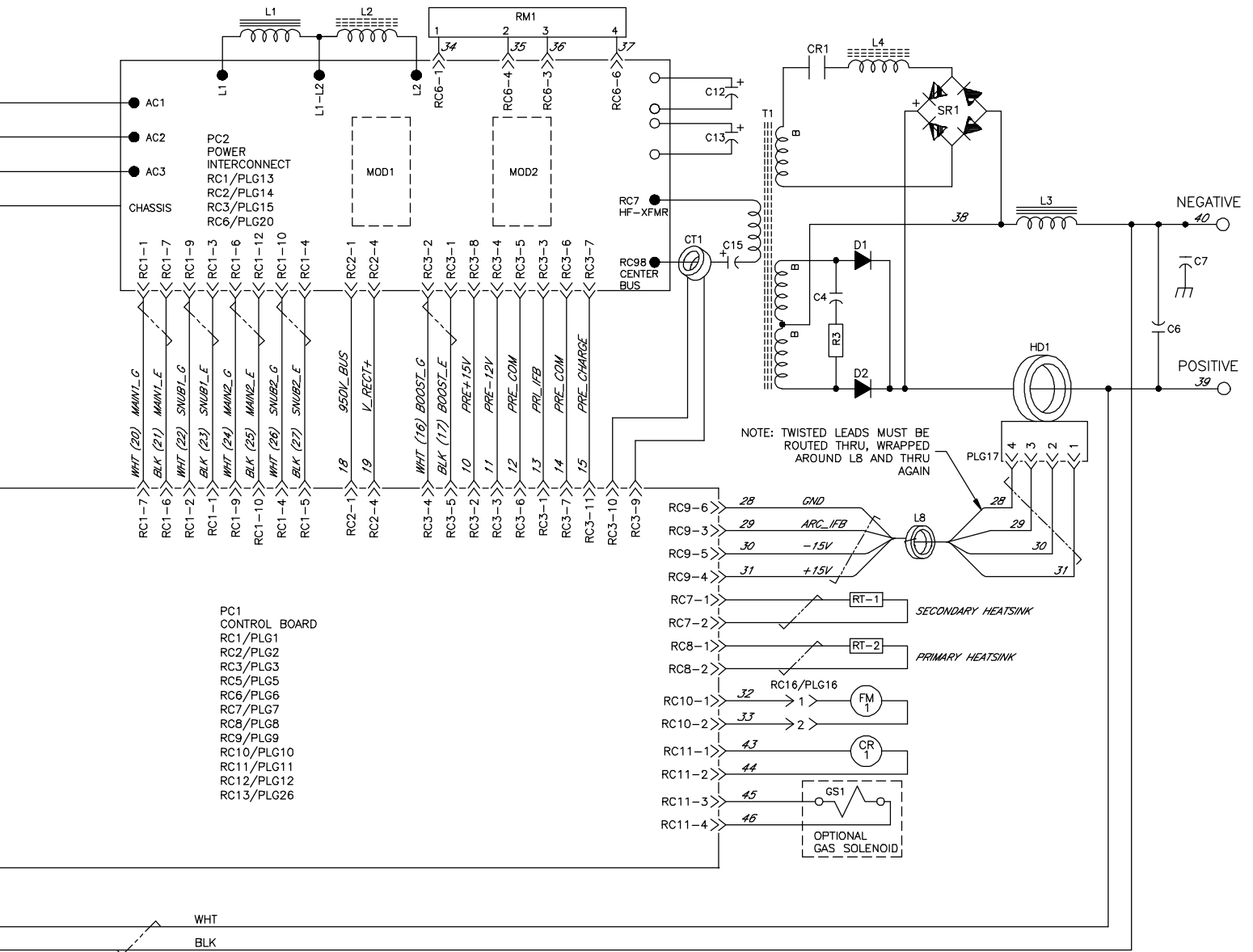

Figure 11-1. Circuit Diagram



Warranty

Effective January 1, 2016

(Equipment with a serial number preface of MG or newer)

This limited warranty supersedes all previous Miller warranties and is exclusive with no other guarantees or warranties expressed or implied.

LIMITED WARRANTY – Subject to the terms and conditions below, warrants to its original retail purchaser that new equipment sold after the effective date of this limited warranty is free of defects in material and workmanship at the time it is shipped from factory. THIS WARRANTY IS EXPRESSLY IN LIEU OF ALL OTHER WARRANTIES, EXPRESS OR IMPLIED, INCLUDING THE WARRANTIES OF MERCHANTABILITY AND FITNESS.

Within the warranty periods listed below, manufacturer will repair or replace any warranted parts or components that fail due to such defects in material or workmanship. Manufacturer must be notified in writing within thirty (30) days of such defect or failure, at which time manufacturer will provide instructions on the warranty claim procedures to be followed. If notification is submitted as an online warranty claim, the claim must include a detailed description of the fault and the troubleshooting steps taken to identify failed components and the cause of their failure.

Manufacturer shall honor warranty claims on warranted equipment listed below in the event of such a failure within the warranty time periods. All warranty time periods start on the delivery date of the equipment to the original end-user purchaser, and not to exceed twelve months after the equipment is shipped to the distributor.

1. 5 Years Parts — 3 Years Labor
 - * Original Main Power Rectifiers Only to Include SCRs, Diodes, and Discrete Rectifier Modules
2. 3 Years — Parts and Labor
 - * Auto-Darkening Helmet Lenses (Except Classic Series) (No Labor)
 - * Engine Driven Welder/Generators
(NOTE: Engines are Warranted Separately by the Engine Manufacturer.)
 - * Inverter Power Sources (Unless Otherwise Stated)
 - * Plasma Arc Cutting Power Sources
 - * Process Controllers
 - * Semi-Automatic and Automatic Wire Feeders
 - * Transformer/Rectifier Power Sources
3. 2 Years — Parts and Labor
 - * Auto-Darkening Helmet Lenses – Classic Series Only (No Labor)
 - * Fume Extractors – Capture 5, Filtair 400 and Industrial Collector Series
4. 1 Year — Parts and Labor Unless Specified
 - * Automatic Motion Devices
 - * CoolBelt and CoolBand Blower Unit (No Labor)
 - * Desiccant Air Dryer System
 - * External Monitoring Equipment and Sensors
 - * Field Options
(NOTE: Field options are covered for the remaining warranty period of the product they are installed in, or for a minimum of one year — whichever is greater.)
 - * RFCS Foot Controls (Except RFCS-RJ45)
 - * Fume Extractors – Filtair 130, MWX and SWX Series
 - * HF Units
 - * ICE/XT Plasma Cutting Torches (No Labor)
 - * Induction Heating Power Sources, Coolers
(NOTE: Digital Recorders are Warranted Separately by the Manufacturer.)
 - * LiveArc Welding Performance Management System
 - * Load Banks
 - * Motor-Driven Guns (except Spoolmate Spoolguns)
 - * PAPR Blower Unit (No Labor)
 - * Positioners and Controllers
 - * Racks
 - * Running Gear/Trailers
 - * Spot Welders
 - * Subarc Wire Drive Assemblies
 - * Water Coolant Systems
 - * TIG Torches (No Labor)
 - * Wireless Remote Foot/Hand Controls and Receivers
 - * Work Stations/Weld Tables (No Labor)

5. 6 Months — Parts
 - * Batteries
 - * Bernard Guns (No Labor)
 - * Tregaskiss Guns (No Labor)
6. 90 Days — Parts
 - * Accessory (Kits)
 - * Canvas Covers
 - * Induction Heating Coils and Blankets, Cables, and Non-Electronic Controls
 - * M-Guns
 - * MIG Guns and Subarc (SAW) Torches
 - * Remote Controls and RFCS-RJ45
 - * Replacement Parts (No labor)
 - * Roughneck Guns
 - * Spoolmate Spoolguns

Limited Warranty shall not apply to:

1. **Consumable components; such as contact tips, cutting nozzles, contactors, brushes, relays, work station table tops and welding curtains, or parts that fail due to normal wear. (Exception: brushes and relays are covered on all engine-driven products.)**
2. Items furnished by manufacturer, but manufactured by others, such as engines or trade accessories. These items are covered by the manufacturer's warranty, if any.
3. Equipment that has been modified by any party other than manufacturer, or equipment that has been improperly installed, improperly operated or misused based upon industry standards, or equipment which has not had reasonable and necessary maintenance, or equipment which has been used for operation outside of the specifications for the equipment.

MANUFACTURER'S PRODUCTS ARE INTENDED FOR PURCHASE AND USE BY COMMERCIAL/INDUSTRIAL USERS AND PERSONS TRAINED AND EXPERIENCED IN THE USE AND MAINTENANCE OF WELDING EQUIPMENT.

In the event of a warranty claim covered by this warranty, the exclusive remedies shall be, at manufacturer's option: (1) repair; or (2) replacement; or, where authorized in writing by manufacturer in appropriate cases, (3) the reasonable cost of repair or replacement at an authorized service station; or (4) payment of or credit for the purchase price (less reasonable depreciation based upon actual use) upon return of the goods at customer's risk and expense. Manufacturer's option of repair or replacement will be F.O.B., Factory at Appleton, Wisconsin, or F.O.B. at an authorized service facility as determined by manufacturer. Therefore no compensation or reimbursement for transportation costs of any kind will be allowed.

TO THE EXTENT PERMITTED BY LAW, THE REMEDIES PROVIDED HEREIN ARE THE SOLE AND EXCLUSIVE REMEDIES. IN NO EVENT SHALL MANUFACTURER BE LIABLE FOR DIRECT, INDIRECT, SPECIAL, INCIDENTAL OR CONSEQUENTIAL DAMAGES (INCLUDING LOSS OF PROFIT), WHETHER BASED ON CONTRACT, TORT OR ANY OTHER LEGAL THEORY.

ANY EXPRESS WARRANTY NOT PROVIDED HEREIN AND ANY IMPLIED WARRANTY, GUARANTY OR REPRESENTATION AS TO PERFORMANCE, AND ANY REMEDY FOR BREACH OF CONTRACT TORT OR ANY OTHER LEGAL THEORY WHICH, BUT FOR THIS PROVISION, MIGHT ARISE BY IMPLICATION, OPERATION OF LAW, CUSTOM OF TRADE OR COURSE OF DEALING, INCLUDING ANY IMPLIED WARRANTY OF MERCHANTABILITY OR FITNESS FOR PARTICULAR PURPOSE, WITH RESPECT TO ANY AND ALL EQUIPMENT FURNISHED BY MANUFACTURER IS EXCLUDED AND DISCLAIMED BY MANUFACTURER.

Some states in the U.S.A. do not allow limitations of how long an implied warranty lasts, or the exclusion of incidental, indirect, special or consequential damages, so the above limitation or exclusion may not apply to you. This warranty provides specific legal rights, and other rights may be available, but may vary from state to state.

In Canada, legislation in some provinces provides for certain additional warranties or remedies other than as stated herein, and to the extent that they may not be waived, the limitations and exclusions set out above may not apply. This Limited Warranty provides specific legal rights, and other rights may be available, but may vary from province to province.



Owner's Record

Please complete and retain with your personal records.

Model Name

Serial/Style Number

Purchase Date

(Date which equipment was delivered to original customer.)

Distributor

Address

City

State

Zip

Red-D-Arc
Welderrentals
1-866-RED-D-ARC reddarc.com

Contact the Delivering Carrier for:

File a claim for loss or damage during shipment.

For assistance in filing or settling claims, contact your distributor and/or equipment manufacturer's Transportation Department.
