

## Operator's Manual

# LF-72 WIRE FEEDER

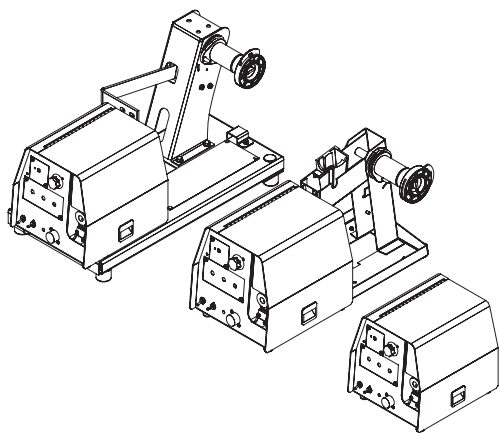

For use with machines having Code Numbers:

**11075, 11076, 11077, 11209, 11210,  
11211, 11227, 11290, 11291, 11292,  
11293, 11606, 11607, 11608, 11609,  
11708, 11709, 11710, 11711**



**Register your machine:**

[www.lincolnelectric.com/register](http://www.lincolnelectric.com/register)

**Authorized Service and Distributor Locator:**

[www.lincolnelectric.com/locator](http://www.lincolnelectric.com/locator)

Save for future reference

Date Purchased

Code: (ex: 10859)

Serial: (ex: U1060512345)

## ⚠ WARNING

### ⚠ CALIFORNIA PROPOSITION 65 WARNINGS ⚠

Diesel engine exhaust and some of its constituents are known to the State of California to cause cancer, birth defects, and other reproductive harm.

The Above For Diesel Engines

The engine exhaust from this product contains chemicals known to the State of California to cause cancer, birth defects, or other reproductive harm.

The Above For Gasoline Engines

**ARC WELDING CAN BE HAZARDOUS. PROTECT YOURSELF AND OTHERS FROM POSSIBLE SERIOUS INJURY OR DEATH. KEEP CHILDREN AWAY. PACEMAKER WEARERS SHOULD CONSULT WITH THEIR DOCTOR BEFORE OPERATING.**

Read and understand the following safety highlights. For additional safety information, it is strongly recommended that you purchase a copy of "Safety in Welding & Cutting - ANSI Standard Z49.1" from the American Welding Society, P.O. Box 351040, Miami, Florida 33135 or CSA Standard W117.2-1974. A Free copy of "Arc Welding Safety" booklet E205 is available from the Lincoln Electric Company, 22801 St. Clair Avenue, Cleveland, Ohio 44117-1199.

**BE SURE THAT ALL INSTALLATION, OPERATION, MAINTENANCE AND REPAIR PROCEDURES ARE PERFORMED ONLY BY QUALIFIED INDIVIDUALS.**



### FOR ENGINE powered equipment.

1.a. Turn the engine off before troubleshooting and maintenance work unless the maintenance work requires it to be running.



1.b. Operate engines in open, well-ventilated areas or vent the engine exhaust fumes outdoors.



1.c. Do not add the fuel near an open flame welding arc or when the engine is running. Stop the engine and allow it to cool before refueling to prevent spilled fuel from vaporizing on contact with hot engine parts and igniting. Do not spill fuel when filling tank. If fuel is spilled, wipe it up and do not start engine until fumes have been eliminated.

1.d. Keep all equipment safety guards, covers and devices in position and in good repair. Keep hands, hair, clothing and tools away from V-belts, gears, fans and all other moving parts when starting, operating or repairing equipment.

1.e. In some cases it may be necessary to remove safety guards to perform required maintenance. Remove guards only when necessary and replace them when the maintenance requiring their removal is complete. Always use the greatest care when working near moving parts.



1.f. Do not put your hands near the engine fan. Do not attempt to override the governor or idler by pushing on the throttle control rods while the engine is running.

1.g. To prevent accidentally starting gasoline engines while turning the engine or welding generator during maintenance work, disconnect the spark plug wires, distributor cap or magneto wire as appropriate.



1.h. To avoid scalding, do not remove the radiator pressure cap when the engine is hot.



### ELECTRIC AND MAGNETIC FIELDS may be dangerous

2.a. Electric current flowing through any conductor causes localized Electric and Magnetic Fields (EMF). Welding current creates EMF fields around welding cables and welding machines

2.b. EMF fields may interfere with some pacemakers, and welders having a pacemaker should consult their physician before welding.

2.c. Exposure to EMF fields in welding may have other health effects which are now not known.

2.d. All welders should use the following procedures in order to minimize exposure to EMF fields from the welding circuit:

2.d.1. Route the electrode and work cables together - Secure them with tape when possible.

2.d.2. Never coil the electrode lead around your body.

2.d.3. Do not place your body between the electrode and work cables. If the electrode cable is on your right side, the work cable should also be on your right side.

2.d.4. Connect the work cable to the workpiece as close as possible to the area being welded.

2.d.5. Do not work next to welding power source.



## ELECTRIC SHOCK can kill.

- 3.a. The electrode and work (or ground) circuits are electrically “hot” when the welder is on. Do not touch these “hot” parts with your bare skin or wet clothing. Wear dry, hole-free gloves to insulate hands.
- 3.b. Insulate yourself from work and ground using dry insulation. Make certain the insulation is large enough to cover your full area of physical contact with work and ground.

**In addition to the normal safety precautions, if welding must be performed under electrically hazardous conditions (in damp locations or while wearing wet clothing; on metal structures such as floors, gratings or scaffolds; when in cramped positions such as sitting, kneeling or lying, if there is a high risk of unavoidable or accidental contact with the workpiece or ground) use the following equipment:**

- Semiautomatic DC Constant Voltage (Wire) Welder.
  - DC Manual (Stick) Welder.
  - AC Welder with Reduced Voltage Control.
- 3.c. In semiautomatic or automatic wire welding, the electrode, electrode reel, welding head, nozzle or semiautomatic welding gun are also electrically “hot”.
- 3.d. Always be sure the work cable makes a good electrical connection with the metal being welded. The connection should be as close as possible to the area being welded.
- 3.e. Ground the work or metal to be welded to a good electrical (earth) ground.
- 3.f. Maintain the electrode holder, work clamp, welding cable and welding machine in good, safe operating condition. Replace damaged insulation.
- 3.g. Never dip the electrode in water for cooling.
- 3.h. Never simultaneously touch electrically “hot” parts of electrode holders connected to two welders because voltage between the two can be the total of the open circuit voltage of both welders.
- 3.i. When working above floor level, use a safety belt to protect yourself from a fall should you get a shock.
- 3.j. Also see Items 6.c. and 8.



## ARC RAYS can burn.

- 4.a. Use a shield with the proper filter and cover plates to protect your eyes from sparks and the rays of the arc when welding or observing open arc welding. Headshield and filter lens should conform to ANSI Z87.1 standards.
- 4.b. Use suitable clothing made from durable flame-resistant material to protect your skin and that of your helpers from the arc rays.
- 4.c. Protect other nearby personnel with suitable, non-flammable screening and/or warn them not to watch the arc nor expose themselves to the arc rays or to hot spatter or metal.



## FUMES AND GASES can be dangerous.

- 5.a. Welding may produce fumes and gases hazardous to health. Avoid breathing these fumes and gases. When welding, keep your head out of the fume. Use enough ventilation and/or exhaust at the arc to keep fumes and gases away from the breathing zone. **When welding with electrodes which require special ventilation such as stainless or hard facing (see instructions on container or MSDS) or on lead or cadmium plated steel and other metals or coatings which produce highly toxic fumes, keep exposure as low as possible and within applicable OSHA PEL and ACGIH TLV limits using local exhaust or mechanical ventilation. In confined spaces or in some circumstances, outdoors, a respirator may be required. Additional precautions are also required when welding on galvanized steel.**
- 5.b. The operation of welding fume control equipment is affected by various factors including proper use and positioning of the equipment, maintenance of the equipment and the specific welding procedure and application involved. Worker exposure level should be checked upon installation and periodically thereafter to be certain it is within applicable OSHA PEL and ACGIH TLV limits.
- 5.c. Do not weld in locations near chlorinated hydrocarbon vapors coming from degreasing, cleaning or spraying operations. The heat and rays of the arc can react with solvent vapors to form phosgene, a highly toxic gas, and other irritating products.
- 5.d. Shielding gases used for arc welding can displace air and cause injury or death. Always use enough ventilation, especially in confined areas, to insure breathing air is safe.
- 5.e. Read and understand the manufacturer's instructions for this equipment and the consumables to be used, including the material safety data sheet (MSDS) and follow your employer's safety practices. MSDS forms are available from your welding distributor or from the manufacturer.
- 5.f. Also see item 1.b.



## WELDING and CUTTING SPARKS can cause fire or explosion.

6.a. Remove fire hazards from the welding area. If this is not possible, cover them to prevent the welding sparks from starting a fire.

Remember that welding sparks and hot materials from welding can easily go through small cracks and openings to adjacent areas. Avoid welding near hydraulic lines. Have a fire extinguisher readily available.

- 6.b. Where compressed gases are to be used at the job site, special precautions should be used to prevent hazardous situations. Refer to "Safety in Welding and Cutting" (ANSI Standard Z49.1) and the operating information for the equipment being used.
- 6.c. When not welding, make certain no part of the electrode circuit is touching the work or ground. Accidental contact can cause overheating and create a fire hazard.
- 6.d. Do not heat, cut or weld tanks, drums or containers until the proper steps have been taken to insure that such procedures will not cause flammable or toxic vapors from substances inside. They can cause an explosion even though they have been "cleaned". For information, purchase "Recommended Safe Practices for the Preparation for Welding and Cutting of Containers and Piping That Have Held Hazardous Substances", AWS F4.1 from the American Welding Society (see address above).
- 6.e. Vent hollow castings or containers before heating, cutting or welding. They may explode.
- 6.f. Sparks and spatter are thrown from the welding arc. Wear oil free protective garments such as leather gloves, heavy shirt, cuffless trousers, high shoes and a cap over your hair. Wear ear plugs when welding out of position or in confined places. Always wear safety glasses with side shields when in a welding area.
- 6.g. Connect the work cable to the work as close to the welding area as practical. Work cables connected to the building framework or other locations away from the welding area increase the possibility of the welding current passing through lifting chains, crane cables or other alternate circuits. This can create fire hazards or overheat lifting chains or cables until they fail.
- 6.h. Also see item 1.c.
- 6.i. Read and follow NFPA 51B "Standard for Fire Prevention During Welding, Cutting and Other Hot Work", available from NFPA, 1 Batterymarch Park, PO box 9101, Quincy, Ma 022690-9101.
- 6.j. Do not use a welding power source for pipe thawing.



## CYLINDER may explode if damaged.

7.a. Use only compressed gas cylinders containing the correct shielding gas for the process used and properly operating regulators designed for the gas and pressure used. All hoses, fittings, etc. should be suitable for the application and maintained in good condition.

- 7.b. Always keep cylinders in an upright position securely chained to an undercarriage or fixed support.
- 7.c. Cylinders should be located:
  - Away from areas where they may be struck or subjected to physical damage.
  - A safe distance from arc welding or cutting operations and any other source of heat, sparks, or flame.
- 7.d. Never allow the electrode, electrode holder or any other electrically "hot" parts to touch a cylinder.
- 7.e. Keep your head and face away from the cylinder valve outlet when opening the cylinder valve.
- 7.f. Valve protection caps should always be in place and hand tight except when the cylinder is in use or connected for use.
- 7.g. Read and follow the instructions on compressed gas cylinders, associated equipment, and CGA publication P-1, "Precautions for Safe Handling of Compressed Gases in Cylinders," available from the Compressed Gas Association 1235 Jefferson Davis Highway, Arlington, VA 22202.



## FOR ELECTRICALLY powered equipment.

- 8.a. Turn off input power using the disconnect switch at the fuse box before working on the equipment.
- 8.b. Install equipment in accordance with the U.S. National Electrical Code, all local codes and the manufacturer's recommendations.
- 8.c. Ground the equipment in accordance with the U.S. National Electrical Code and the manufacturer's recommendations.

Refer to <http://www.lincolnelectric.com/safety> for additional safety information.

## PRÉCAUTIONS DE SÛRETÉ

Pour votre propre protection lire et observer toutes les instructions et les précautions de sûreté spécifiques qui paraissent dans ce manuel aussi bien que les précautions de sûreté générales suivantes:

### Sûreté Pour Soudage A L'Arc

1. Protégez-vous contre la secousse électrique:
  - a. Les circuits à l'électrode et à la pièce sont sous tension quand la machine à souder est en marche. Eviter toujours tout contact entre les parties sous tension et la peau nue ou les vêtements mouillés. Porter des gants secs et sans trous pour isoler les mains.
  - b. Faire très attention de bien s'isoler de la masse quand on soude dans des endroits humides, ou sur un plancher métallique ou des grilles métalliques, principalement dans les positions assis ou couché pour lesquelles une grande partie du corps peut être en contact avec la masse.
  - c. Maintenir le porte-électrode, la pince de masse, le câble de soudage et la machine à souder en bon et sûr état de fonctionnement.
  - d. Ne jamais plonger le porte-électrode dans l'eau pour le refroidir.
  - e. Ne jamais toucher simultanément les parties sous tension des porte-électrodes connectés à deux machines à souder parce que la tension entre les deux pinces peut être le total de la tension à vide des deux machines.
  - f. Si on utilise la machine à souder comme une source de courant pour soudage semi-automatique, ces précautions pour le porte-électrode s'appliquent aussi au pistolet de soudage.
2. Dans le cas de travail au dessus du niveau du sol, se protéger contre les chutes dans le cas où on recoit un choc. Ne jamais enrouler le câble-électrode autour de n'importe quelle partie du corps.
3. Un coup d'arc peut être plus sévère qu'un coup de soliel, donc:
  - a. Utiliser un bon masque avec un verre filtrant approprié ainsi qu'un verre blanc afin de se protéger les yeux du rayonnement de l'arc et des projections quand on soude ou quand on regarde l'arc.
  - b. Porter des vêtements convenables afin de protéger la peau de soudeur et des aides contre le rayonnement de l'arc.
  - c. Protéger l'autre personnel travaillant à proximité au soudage à l'aide d'écrans appropriés et non-inflammables.
4. Des gouttes de laitier en fusion sont émises de l'arc de soudage. Se protéger avec des vêtements de protection libres de l'huile, tels que les gants en cuir, chemise épaisse, pantalons sans revers, et chaussures montantes.

5. Toujours porter des lunettes de sécurité dans la zone de soudage. Utiliser des lunettes avec écrans latéraux dans les zones où l'on pique le laitier.
6. Eloigner les matériaux inflammables ou les recouvrir afin de prévenir tout risque d'incendie dû aux étincelles.
7. Quand on ne soude pas, poser la pince à un endroit isolé de la masse. Un court-circuit accidentel peut provoquer un échauffement et un risque d'incendie.
8. S'assurer que la masse est connectée le plus près possible de la zone de travail qu'il est pratique de le faire. Si on place la masse sur la charpente de la construction ou d'autres endroits éloignés de la zone de travail, on augmente le risque de voir passer le courant de soudage par les chaînes de levage, câbles de grue, ou autres circuits. Cela peut provoquer des risques d'incendie ou d'échauffement des chaînes et des câbles jusqu'à ce qu'ils se rompent.
9. Assurer une ventilation suffisante dans la zone de soudage. Ceci est particulièrement important pour le soudage de tôles galvanisées plombées, ou cadmiées ou tout autre métal qui produit des fumees toxiques.
10. Ne pas souder en présence de vapeurs de chlore provenant d'opérations de dégraissage, nettoyage ou pistolage. La chaleur ou les rayons de l'arc peuvent réagir avec les vapeurs du solvant pour produire du phosgène (gas fortement toxique) ou autres produits irritants.
11. Pour obtenir de plus amples renseignements sur la sûreté, voir le code "Code for safety in welding and cutting" CSA Standard W 117.2-1974.

## PRÉCAUTIONS DE SÛRETÉ POUR LES MACHINES À SOUDER À TRANSFORMATEUR ET À REDRESSEUR

1. Relier à la terre le châssis du poste conformément au code de l'électricité et aux recommandations du fabricant. Le dispositif de montage ou la pièce à souder doit être branché à une bonne mise à la terre.
2. Autant que possible, l'installation et l'entretien du poste seront effectués par un électricien qualifié.
3. Avant de faire des travaux à l'intérieur de poste, la débrancher à l'interrupteur à la boîte de fusibles.
4. Garder tous les couvercles et dispositifs de sûreté à leur place.

# Thank You

for selecting a **QUALITY** product by Lincoln Electric. We want you to take pride in operating this Lincoln Electric Company product  
••• as much pride as we have in bringing this product to you!

### CUSTOMER ASSISTANCE POLICY

The business of The Lincoln Electric Company is manufacturing and selling high quality welding equipment, consumables, and cutting equipment. Our challenge is to meet the needs of our customers and to exceed their expectations. On occasion, purchasers may ask Lincoln Electric for advice or information about their use of our products. We respond to our customers based on the best information in our possession at that time. Lincoln Electric is not in a position to warrant or guarantee such advice, and assumes no liability, with respect to such information or advice. We expressly disclaim any warranty of any kind, including any warranty of fitness for any customer's particular purpose, with respect to such information or advice. As a matter of practical consideration, we also cannot assume any responsibility for updating or correcting any such information or advice once it has been given, nor does the provision of information or advice create, expand or alter any warranty with respect to the sale of our products.

Lincoln Electric is a responsive manufacturer, but the selection and use of specific products sold by Lincoln Electric is solely within the control of, and remains the sole responsibility of the customer. Many variables beyond the control of Lincoln Electric affect the results obtained in applying these types of fabrication methods and service requirements.

Subject to Change – This information is accurate to the best of our knowledge at the time of printing. Please refer to [www.lincolnelectric.com](http://www.lincolnelectric.com) for any updated information.

### Please Examine Carton and Equipment For Damage Immediately

When this equipment is shipped, title passes to the purchaser upon receipt by the carrier. Consequently, Claims for material damaged in shipment must be made by the purchaser against the transportation company at the time the shipment is received.

Please record your equipment identification information below for future reference. This information can be found on your machine nameplate.

Product \_\_\_\_\_

Model Number \_\_\_\_\_

Code Number or Date Code \_\_\_\_\_

Serial Number \_\_\_\_\_

Date Purchased \_\_\_\_\_

Where Purchased \_\_\_\_\_

Whenever you request replacement parts or information on this equipment, always supply the information you have recorded above. The code number is especially important when identifying the correct replacement parts.

### On-Line Product Registration

- Register your machine with Lincoln Electric either via fax or over the Internet.
  - For faxing: Complete the form on the back of the warranty statement included in the literature packet accompanying this machine and fax the form per the instructions printed on it.
  - For On-Line Registration: Go to our **WEB SITE** at [www.lincolnelectric.com](http://www.lincolnelectric.com). Choose "Quick Links" and then "Product Registration". Please complete the form and submit your registration.

**Read this Operators Manual completely** before attempting to use this equipment. Save this manual and keep it handy for quick reference. Pay particular attention to the safety instructions we have provided for your protection. The level of seriousness to be applied to each is explained below:

### **WARNING**

This statement appears where the information **must** be followed **exactly** to avoid **serious personal injury** or **loss of life**.

### **CAUTION**

This statement appears where the information **must** be followed to avoid **minor personal injury** or **damage to this equipment**.

	Page
<b>Installation .....</b>	<b>Section A</b>
Technical Specifications .....	A-1
Safety Precautions.....	A-2
Location .....	A-2
Mounting.....	A-2
Bench Mount .....	A-3
Swivel Mount .....	A-3
Boom Mount .....	A-3
Suspended .....	A-3
Weld Cable Sizes .....	A-4
Coaxial Weld Cables .....	A-5
Weld Cable Connections .....	A-5
Analog Control Cable Connections .....	A-6
Analog Miller Control Cable Adapter .....	A-7
Welding Gun/Wire Feeder Trigger Connector .....	A-8
High Frequency Protection .....	A-8
Remote Sense Lead Specifications .....	A-8
Wire Drive Systems .....	A-8
Welding Guns, Torches and Accessories.....	A-9
Procedure for Changing Drive and Idle Roll Sets .....	A-10
Wire Drive Configuration .....	A-10, A-11
Pressure Arm Adjustment.....	A-11
Wire Reel Loading .....	A-12
Weld Wire Routing.....	A-13
Shielding Gas Connections .....	A-14
Installing Electrode Conduit Kits.....	A-15
Aluminum Wire Preparations .....	A-16
Base Model, Bench Model Standard Duty and Bench Model Heavy Duty .....	A-17
Typical System Configurations .....	A-18
<hr/>	
<b>Operation .....</b>	<b>Section B</b>
Safety Precautions.....	B-1
Graphic Symbols.....	B-1
Common Welding Abbreviations.....	B-2
Product Description.....	B-2
Recommended Processes and Required Equipment .....	B-2
Front Panel Controls and Connections .....	B-3
1. Remote Voltage Control Kit (Optional).....	B-4
2. Burnback and Postflow Timer Kit (Optional).....	B-4
3. Thermal LED, Motor Overload .....	B-4
4. Cold Feed/Gas Purge Switch.....	B-4
5. 2 Step - Trigger Interlock Switch .....	B-4, B-5
6. Wire Feed Speed Knob.....	B-5
7. Gun Receiver Bushing .....	B-5
8. Trigger Connector 5-Pin Amphenol .....	B-5
<hr/>	
<b>Accessories .....</b>	<b>Section C</b>
General Options and Accessories .....	C-1 Thru C4

---

<b>Maintenance .....</b>	<b>Section D</b>
Safety Precautions .....	D-1
Routine Maintenance.....	D-1
Periodic Maintenance .....	D-1
Calibration Specification .....	D-1
Major Component Locations.....	D-2

---

<b>Troubleshooting .....</b>	<b>Section E</b>
Safety Precautions.....	E-1
How To Use Troubleshooting Guide.....	E-1
Troubleshooting Guides .....	E-2, E-3

---

<b>Wiring Diagram and Dimension Prints .....</b>	<b>Section F</b>
--	------------------

---

<b>Parts Lists.....</b>	<b>P-501 and P-622</b>
-------------------------	------------------------

---



## TECHNICAL SPECIFICATIONS: LF-72 Wire Feeder

SPEC.#		TYPE	WIRE FEED SPEED RANGE		
		LF-72	Speed	Wire Size	
				Solid	Cored
K2327-1 K2327-4	Base Model	50-800 IPM (1.27-20.3 m/m)		.023 - 1/16 in. (0.6 - 1.6 mm)	.035 - 5/64 in. (0.9 - 2.0 mm)
K2327-2 K2327-5	Bench Model Standard Duty				
K2327-3 K2327-6	Bench Model				
K2327-7	Heavy Duty				

CONTROL BOX, WIRE DRIVE AND COMPLETE UNITS								
SPEC.#	TYPE	INPUT POWER	PHYSICAL SIZE			TEMPERATURE RATING		
		Input Voltage and Current	Dimensions			Weight	Operating	Storage
			Height	Width	Depth			
K2327-1	LF-72	24-42VAC 9 AMPS	11.1" (282 mm)	10.2" (259 mm)	12.9" (328 mm)	43 Lbs (19.7 Kg.)	14°F to 104°F (-10°C to 40°C)	-40°F to 185°F (-40°C to 85°C)
K2327-4	Base Model					26.5 Lbs (12.0 Kg.)		
K2327-2 K2327-5	LF-72 Bench Standard Duty		Dimensions ∅			Weight		
			Height	Width	Depth			
			12.6" (320 mm)	10.9" (277 mm)	22.5" (572 mm)	52.5 Lbs (23.8 Kg.)		
K2327-3 K2327-6 K2327-7	LF-72 Bench Heavy Duty		Dimensions ∅			Weight		
		Height	Width	Depth				
		15.3" (389 mm)	13.0" (330 mm)	27.7" (704 mm)	67.5 Lbs (30.6 Kg.)			

WELDING CAPACITY RATING	
Amp Rating	Duty Cycle
500 A	60%

∅Dimensions do not include wire reel.

## SAFETY PRECAUTION



### ELECTRIC SHOCK can kill.

- Only qualified personnel should perform this installation.
- Turn off the input power to the power source at the disconnect switch or fuse box before working on this equipment. Turn off the input power to any other equipment connected to the welding system at the disconnect switch or fuse box before working on this equipment.

- Do not touch electrically hot parts.

## LOCATION

The LF-72 may be placed on a bench or mounted on top of a welding power source.

Place the LF-72 in a clean and dry location.

Do not stack the LF-72.

## MOUNTING

For location and size, LF-72 Bench Model Rear Mounting Holes (See Figure A.1) and for Bottom Mounting Holes (See Figure A.2).

FIGURE A.1

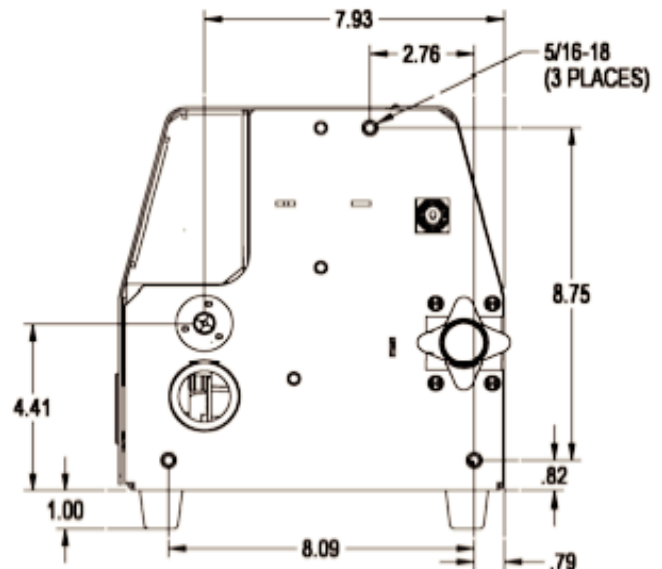
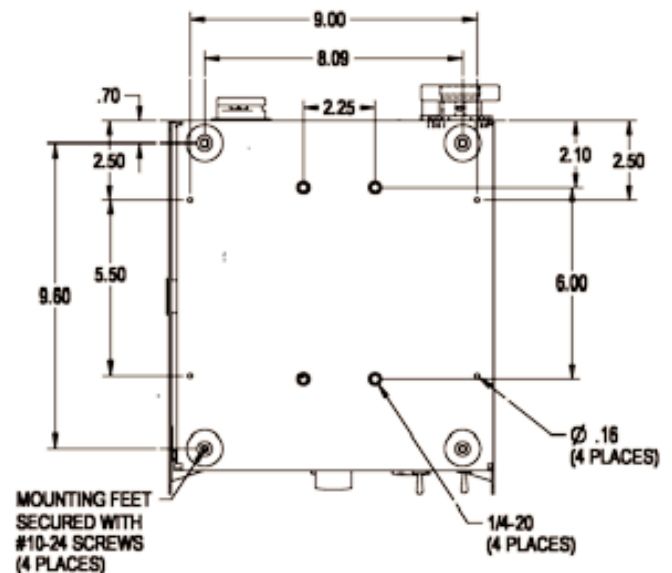

FIGURE A.2



LF-72

**LINCOLN**  
ELECTRIC

## BENCH MOUNT

The LF-72 mounts in a variety of configurations. As shipped from the factory, the LF-72 is suitable for bench mounting or placing directly on top of the welding power source (CV-xxx and DC-xxx product family only).

Bench Mount

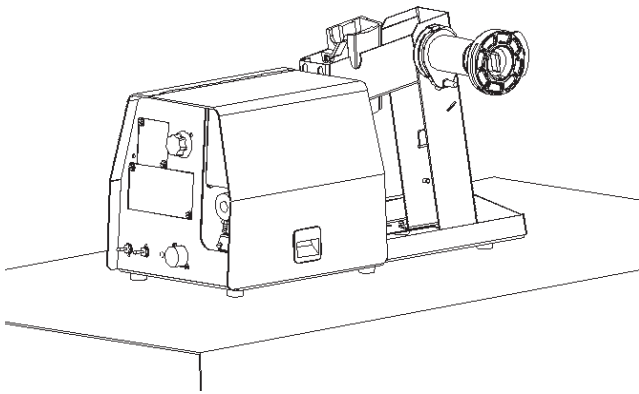

## SWIVEL MOUNT

Both the standard duty bench model and heavy duty bench model may be mounted onto a swivel when a top a welding power source.

Swivel Kit and Bench Model, Standard Duty

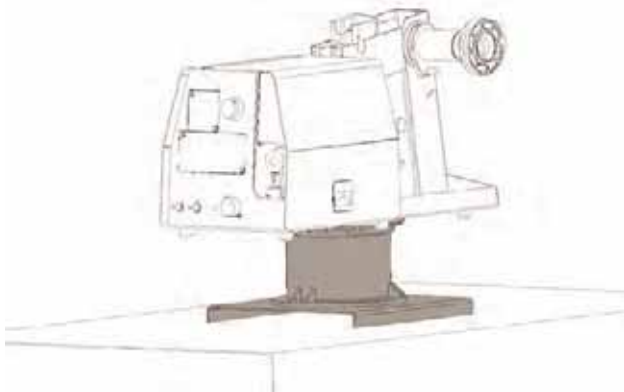

Swivel Kit and Base Model LF-72

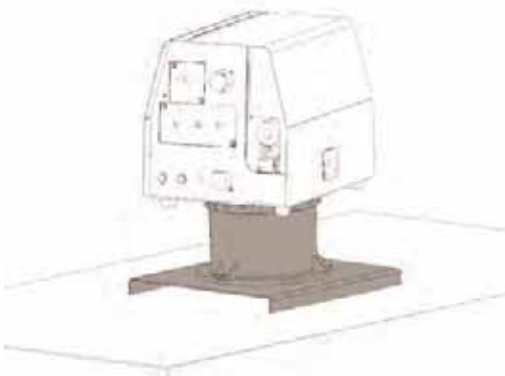

## BOOM MOUNT

When boom mounting, remove the wire reel stand (if assembled) and secure the wire feeder directly to the desired surface.

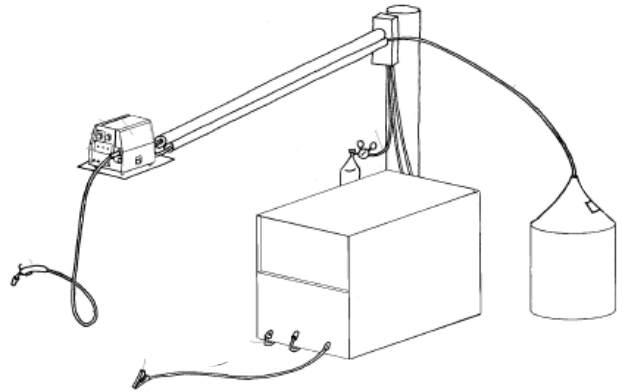

## SUSPENDED

Only suspend the wire feeder by the lift bail of the portability kit.



## **⚠ WARNING**

Alternative methods for hanging the wire feeder must not be used unless insulation is provided between the wire feeder enclosure and the hanging device.

---

## SAFETY PRECAUTION



**ELECTRIC SHOCK can kill.**

- Only qualified personnel should perform this installation.
- Turn off the input power to the power source at the disconnect switch or fuse box before working on this equipment. Turn off the input power to any other equipment connected to the welding system at the disconnect switch or fuse box before working on this equipment.
- Do not touch electrically hot parts.

-----

**WELD CABLE SIZES**

Table A.1 has the copper cable sizes recommended for different currents and duty cycles. Lengths stipulated are the distance from the welder to work and back to the welder again. Cable sizes are increased for greater lengths primarily for the purpose of minimizing voltage in the welding circuit.

TABLE A.1

RECOMMENDED CABLE SIZES (RUBBER COVERED COPPER - RATED 75°C)**						
Amperes	Percent Duty Cycle	CABLE SIZES FOR COMBINED LENGTHS OF ELECTRODE AND WORK CABLES				
		0 to 50 Ft.	50 to 100Ft.	100 to 150 Ft.	150 to 200 Ft.	200 to 250 Ft.
		0 to 15 m	15 to 31 m	31 to 48 m	48 to 61 m	61 to 76 m
200	60	2	2	2	1	1/0
200	100	2	2	2	1	1/0
225	20	4 or 5	3	2	1	1/0
225	40 & 30	3	3	2	1	1/0
250	30	3	3	2	1	1/0
250	40	2	2	1	1	1/0
250	60	1	1	1	1	1/0
250	100	1	1	1	1	1/0
300	60	1	1	1	1/0	2/0
325	100	2/0	2/0	2/0	2/0	3/0
350	60	1/0	1/0	2/0	2/0	3/0
400	60	2/0	2/0	2/0	3/0	4/0
400	100	3/0	3/0	3/0	3/0	4/0
500	60	2/0	2/0	3/0	3/0	4/0

\*\* Tabled values are for operation at ambient temperatures of 40°C and below. Applications above 40°C may require cables larger than recommended, or cables rated higher than 75°C.

## COAXIAL WELD CABLES

Coaxial welding cables are specially designed welding cables for pulse welding or STT welding. Coaxial weld cables feature low inductance, allowing fast changes in the weld current. Regular cables have a higher inductance which may distort the pulse or STT wave shape. Inductance becomes more severe as the weld cables become longer.

Coaxial weld cables are recommended for all pulse and STT welding, especially when the total weld cable length (electrode cable + work cable) exceeds 50 feet (7.6m)

A coaxial weld cable is constructed by 8 small leads wrapped around one large lead. The large inner lead connects to the electrode stud on the power source and the electrode connection on the wire feeder. The small leads combine together to form the work lead, one end attached to the power source and the other end to the work piece. (See Coaxial weld Cable below.)

## WELD CABLE CONNECTION

Connect a work lead of sufficient size between the proper output stud on the power source and the work. Be sure the connection to the work makes tight metal to metal electrical contact. Poor work lead connections can result in poor welding performance.

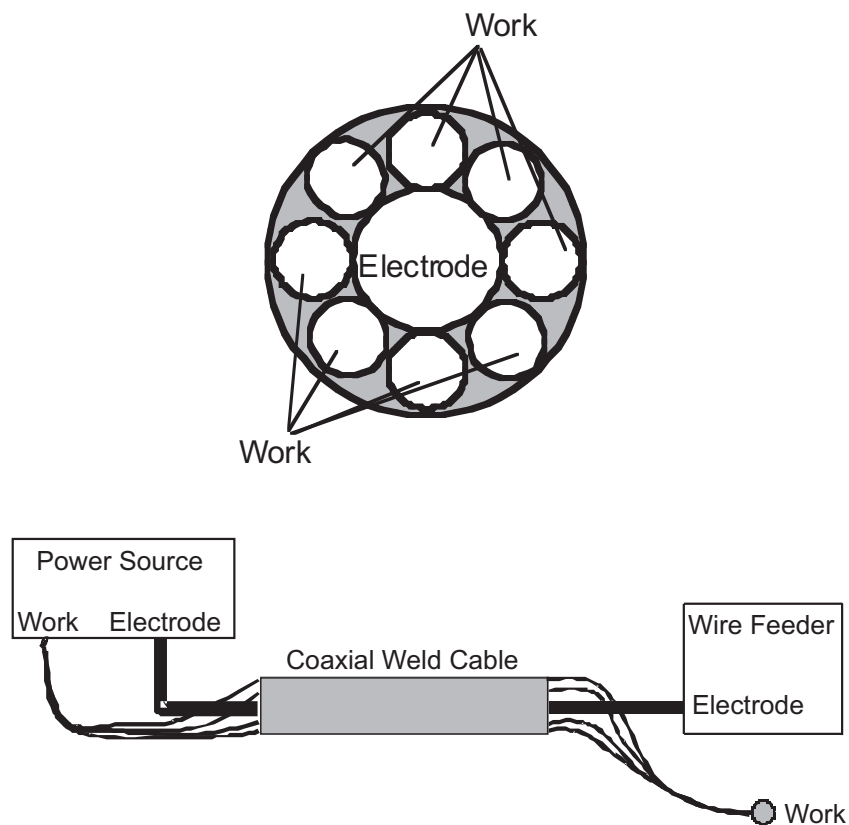

LF-72

**LINCOLN**<sup>®</sup>  
ELECTRIC

## ANALOG CONTROL CABLE CONTROL CABLE CONNECTIONS

- All control cables can be connected end to end to extend their length.

The control cable connecting the wire feeder to the power source is specially made for the welding environment.

The wire feeder power requires overcurrent protection. Connect the wire feeder only to power sources with overcurrent protection of no more than 15 amps.

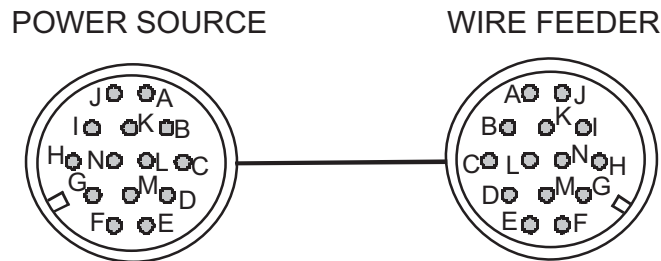

PIN	FUNCTION	LEAD#
A	Unused	-----
B	Reserved	-----
C	Welding Output Control (trigger from feeder)	2
D	Welding Output Control (trigger from feeder)	4
E	Remote Voltage Control ("+" supply from feeder or remote)	77
F	Remote Voltage Control (control signal from feeder or remote)	76
G	Remote Voltage Control ("-" supply from feeder or remote)	75
H	Reserved	
I	42 VAC	41
J	Reserve for Future Use.	
K	42 VAC	42
L	Reserve for Future Use.	
M	Unused	-----
N	Electrode voltage from feeder	67

Do not use more than 100 ft (30.5 m) of control cable between the wire feeder and power source.

## ANALOG MILLER CONTROL CABLE ADAPTER K2335-1

This Lincoln Electric wire feeder may be mounted to a limited number of Miller Electric power sources. The Miller power source must have the amphenol pin definition shown in the table below for proper operation of the wire feeder.

Operation of Lincoln wire feeders on Miller power sources may result in lack of high speeds or reduce pull force on high wire feed speeds. Maximum wire feed speed for the LF-72 operating on a Miller power source is approximately 720ipm. Be sure the Miller power source provides 24 VAC to the wire feeder and has overcurrent protection of no more than 15 amps. The power source must not exceed 113VDC peak.

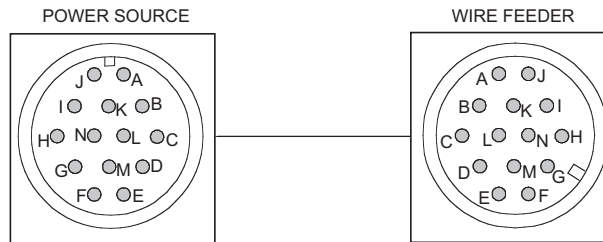

MILLER POWER SOURCE		LINCOLN WIRE FEEDER	
Pin	Function	Pin	Function
A	24 VAC to feeder	I	42 VAC feeder
B	Welding Output Control	D	Welding Output Control
C	+10VDC to feeder for remote control	C	Welding Output Control
D	Remote control common	E	Remote Voltage Control ("+" supply, from power source)
E	0-10VDC from feeder for remote control.	G	Remote Voltage Control ("- " supply, from power source)
F	Current feedback to feeder. Scaled 0-10V. 1 V = 100 amps. Referenced to pin D.	F	Remote Voltage Control (control signal from feeder or remote.)
G	24 VAC common.	J	Reserved for future use.
H	Arc Voltage feedback to feeder. Scaled 0-10V. 1 V = 10 Arc volts. Referenced to pin D.	K	42 VAC to feeder
I		L	Reserved for future use.
J			
K			
L			
M			
N		N	Electrode voltage to power source (67)

Miller is a registered trademark not owned or licensed by The Lincoln Electric Company.

## WELDING GUN/WIRE FEEDER TRIGGER CONNECTOR

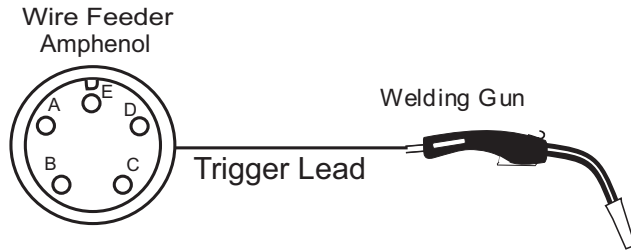

### Wire Feeder

Pin	Function
A	Gun Trigger
B	-
C	Common
D	-
E	-

## HIGH FREQUENCY PROTECTION

Locate the LF-72 away from radio controlled machinery. The normal operation of the LF-72 may adversely affect the operation of RF controlled equipment, which may result in bodily injury or damage to the equipment

## REMOTE SENSE LEAD SPECIFICATIONS

Refer to the power source instruction manual for instructions for connecting the wire feeder for STT welding.

## WIRE DRIVE SYSTEMS

Drive Roll Kits are designed to feed specific types and wire sizes. The LF-72 Bench Model comes with the combo **KP1696-1**. All other Drive Roll Kits listed are not included, but are available for ordering from the following tables:

### Drive Roll Kits, Steel Wires

Includes: 2 Smooth V groove drive rolls and an inner wire guide.

KP1696-030S	.023-.030 (0.6-0.8mm)
KP1696-035S	.035 (0.9mm)
KP1696-045S	.045 (1.2mm)
KP1696-052S	.052 (1.4mm)
KP1696-1/16S	1/16 (1.6mm)
<b>KP1696-1</b>	<b>.035, .045 (0.9, 1.2mm)</b>
KP1696-2	.040 (1.0mm)

### Drive Roll Kits, Cored Wires

Includes: 2 Knurled drive rolls and an inner wire guide.

KP1697-035C	.030-.035" (0.8-0.9mm)
KP1697-045C	.040-.045" (1.0-1.2mm)
KP1697-052C	.052" (1.4mm)
KP1697-1/16C	1/16" (1.6mm)
KP1697-068	.068-.072" (1.7-1.8mm)
KP1697-5/64C	5/64" (2.0mm)

### Drive Roll Kits, Aluminum Wire

Includes: 2 polished U groove drive rolls, outer wire guide and an inner wire guide.

KP1695-035A	.035" (0.9 mm)
KP1695-040A	.040" (1.0mm)
KP1695-3/64A	3/64" (1.2mm)
KP1695-1/16A	1/16" (1.6mm)

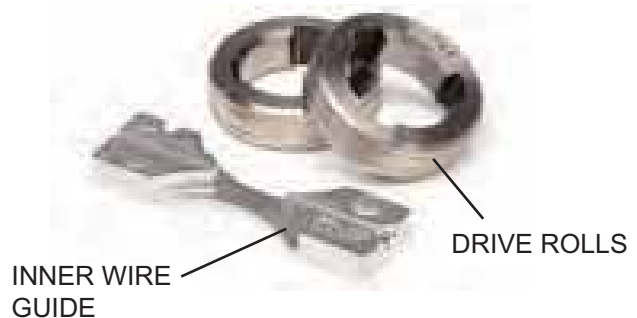



## WELDING GUNS, TORCHES AND ACCESSORIES

### GUN RECEIVER BUSHING

The LF-72 wire feeder comes with a K1500-2 gun receiver bushing.

### MAGNUM GUN AND CABLE ASSEMBLIES

The LF-72 wire feeder model will accept a number of optional gun and cable assemblies. An example of installing the Gun and Cable is shown in **Figure A.3** with a 15 ft. (4.6m) long **Magnum 400** gun and cable. **Figure A.3a** with a 15 ft. (4.6m) long **Magnum Pro 350** gun and cable.

1. Turn off power at the welding power source.
2. Unscrew Thumb screw on Wire Drive Unit, until tip of screw no longer protrudes into gun bushing hole as seen from the front of machine.

**Figure A.3**

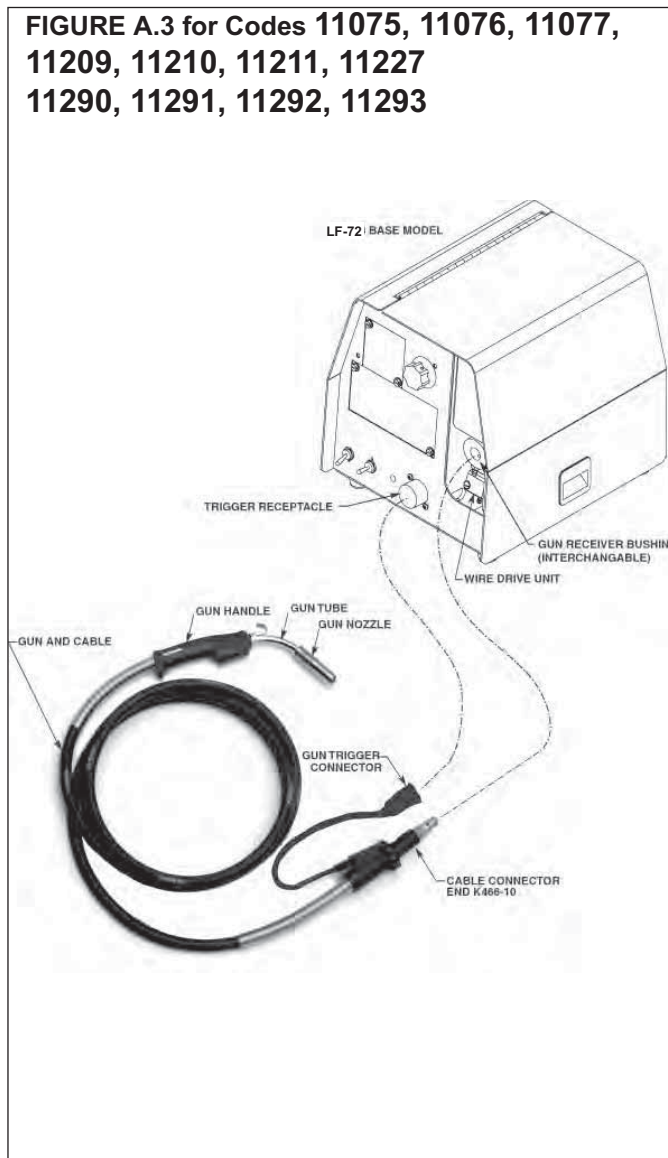

3. Fully insert the gun cable connector end into the gun receiver bushing and gently tighten the thumb screw as shown in Figure A.5.
4. Connect the gun trigger connector to the trigger receptacle. Make sure that the key ways are aligned and insert.

**Figure A.3a**

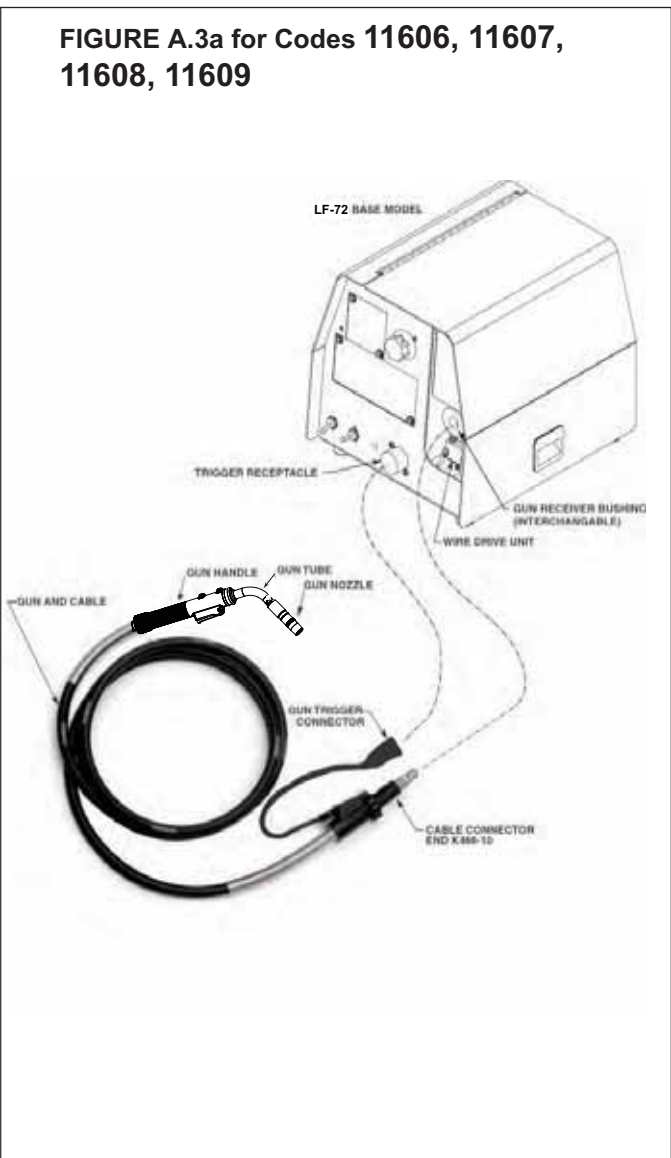

## PROCEDURE FOR CHANGING DRIVE AND IDLE ROLL SETS

(See Figure A.4 )



### WARNING

**ELECTRIC SHOCK can kill.**



- Turn the input power OFF at the welding power source before installation or changing drive rolls and/or guides.
- Do not touch electrically live parts.
- When inching with the gun trigger, electrode and drive mechanism are "hot" to work and ground and could remain energized several seconds after the gun trigger is released.
- Only qualified personnel should perform maintenance work.

1. Turn power off at the welding power source.
2. Release the idle roll pressure arm.
3. Remove the outer wire guide by turning the knurled thumbscrews counter-clockwise to unscrew them from the feed plate.
4. Rotate the triangular lock and remove the drive rolls.

**FIGURE A.4**

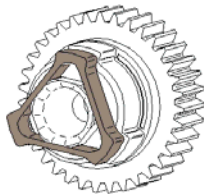

**UNLOCKED POSITION**

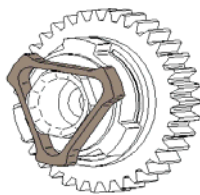

**LOCKED POSITION**

5. Remove the inner wire guide.
6. Insert the new inner wire guide, groove side out, over the two locating pins in the feed plate.
7. Install a drive roll on each hub assembly secure with the triangular lock.
8. Install the outer wire guide by aligning it with the pins and tightening the knurled thumbscrews.
9. Close the idle arm and engage the idle roll pressure arm. Adjust the pressure appropriately.

## WIRE DRIVE CONFIGURATION

(See Figure A.5)

### Changing the Gun Receiver Bushing



### WARNING

**ELECTRIC SHOCK can kill.**



- Turn the input power OFF at the disconnect switch or fuse box before attempting to connect or disconnect input power lines, output cables or control cables.
- Only qualified personnel should perform this installation.

Tools required:

- 1/4" hex key wrench

Note: Some gun bushings do not require the use of the thumb screw.

1. Turn power off at the welding power source.
2. Remove the welding wire from the wire drive.
3. Remove the thumb screw from the wire drive.
4. Remove the welding gun from the wire drive.
5. Loosen the socket head cap screw that holds the connector bar against the gun bushing. Important: Do not attempt to completely remove the socket head cap screw.
6. Remove the outer wire guide, and push the gun bushing out of the wire drive. Because of the precision fit, light tapping may be required to remove the gun bushing.

**FIGURE A.5**

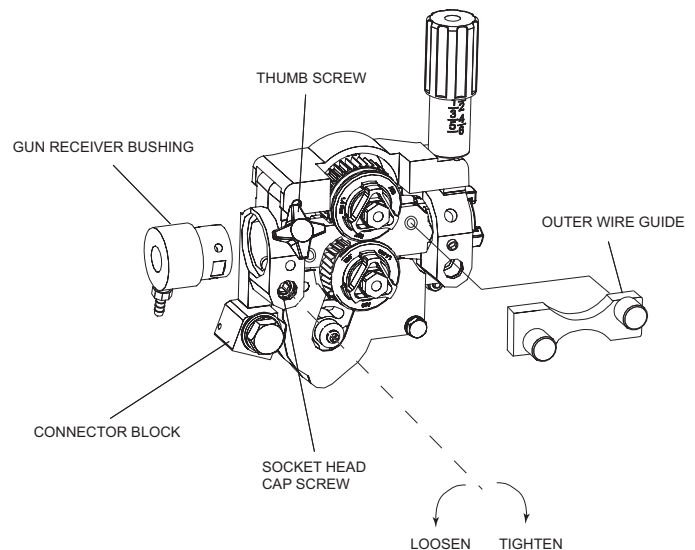

7. Disconnect the shielding gas hose from the gun bushing, if required.
8. Connect the shielding gas hose to the new gun bushing, if required.
9. Rotate the gun bushing until the thumb screw hole aligns with the thumb screw hole in the feed plate. Slide the gun receiver bushing into the wire drive and verify the thumb screw holes are aligned.
10. Tighten the socket head cap screw.
11. Insert the welding gun into the gun bushing and tighten the thumb screw.

Gun Receiver Bushing	For use With
K1500-1	K466-1 Lincoln gun connectors; Innershield and Subarc guns)
K1500-2	K466-2, K466-10 Lincoln gun connectors; Magnum 200/300/400 guns and compatible with Tweco® #4)
K1500-3	K1637-7 Lincoln gun connectors; Magnum 550 guns and compatible with Tweco® #5)
K1500-4	K466-3 Lincoln gun connectors; compatible with Miller® guns.)
K1500-5	(Compatible with Oxo® guns.)
K489-7	( Lincoln Fast-Mate guns.)

## PRESSURE ARM ADJUSTMENT



### WARNING

ELECTRIC SHOCK can kill.



- Turn the input power OFF at the welding power source before installation or changing drive rolls and/or guides.
- Do not touch electrically live parts.
- When inching with the gun trigger, electrode and drive mechanism are "hot" to work and ground and could remain energized several seconds after the gun trigger is released.
- Only qualified personnel should perform maintenance work.

The pressure arm controls the amount of force the drive rolls exert on the wire. Proper adjustment of the pressure arm gives the best welding performance.

#### Set the pressure arm as follows (See Figure A.6):

Aluminum wires	between 1 and 3
Cored wires	between 3 and 4
Steel, Stainless wires	between 4 and 6

FIGURE A.6

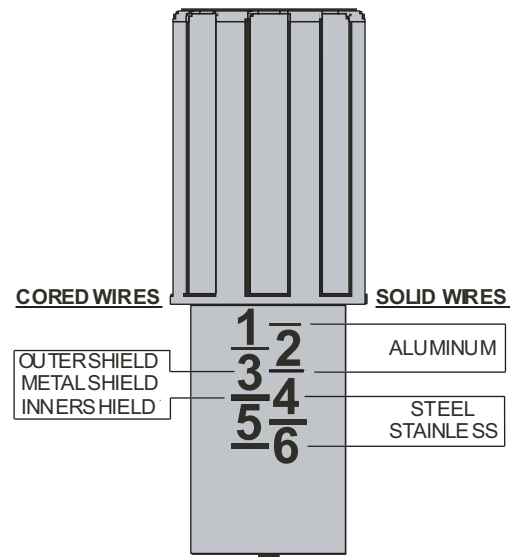

## WIRE REEL LOADING

### WARNING

- Keep hands, hair, clothing and tools away from rotating equipment.
- Do not wear gloves when threading wire or changing wire spool.
- Only qualified personnel should install, use or service this equipment.

### Loading 10 to 15 lb. (4.5 – 6.8kg) Spools

A K468 spindle adapter is required for loading 2" wide spools on 2" (51mm) spindles. Use a K468-1 spindle adapter for loading 2-1/2" (64mm) wide spools. (See figure A.7 and figure A.8)

1. Squeeze the release bar on the retaining collar and remove it from the spindle.
2. Place the spindle adapter on the spindle, aligning the spindle brake pin with the hole in the adapter.
3. Place the spool on the spindle and align the adapter brake tab with one of the holes in the back side of the spool. An indicator mark on the end of the spindle shows the orientation of the brake tab. Be certain the wire feeds off of the spool in the proper direction.
4. Re-install the retaining collar. Make sure that the release bar snaps out and that the retaining collar fully engages the groove on the spindle.

FIGURE A.7

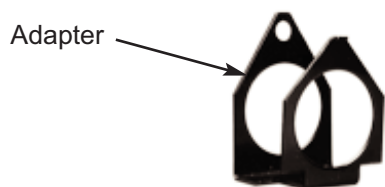

### Spindle Placement

The wire reel stand provides two mounting locations for the spindle. Each mounting location consists of a tube in the center of the mast and locating slots.

### Loading 16 to 44 lb. (7.3 – 20kg) Spools

(See figure A.8)

1. Squeeze the release bar on the retaining collar and remove it from the spindle.
2. Place the spool on the spindle, aligning the spindle brake pin with one of the holes in the back side of the spool. An indicator mark on the end of the spindle shows the orientation of the brake holding pin. Be certain the wire feeds off of the spool in the proper direction.

3. Re-install the retaining collar. Make sure that the release bar snaps out and that the retaining collar fully engages the groove on the spindle.

FIGURE A.8



### Loading 30 lb. (13.6 kg) Readi-Reels

(See Figure A.9)

A K363-P Readi-Reel adapter is required for loading these spools on 2" (51mm) spindles.

1. Squeeze the release bar on the retaining collar and remove it from the spindle.
2. Place the Readi-Reel adapter on the spindle, aligning the spindle brake pin with one of the holes in the adapter.
3. Re-install the retaining collar. Make sure that the release bar snaps out and that the retaining collar fully engages the groove on the spindle.
4. Rotate the spindle and adapter until the retaining spring is at the 12 o'clock position.
5. Position the Readi-Reel so that electrode de-reels in the proper direction.
6. Set one of the Readi-Reel inside cage wires on the slot in the retaining spring.
7. Lower the Read-Reel to depress the retaining spring and align the other inside cage wires with the grooves in the adapter.
8. Slide the cage all way onto the adapter until the retaining spring "pops up" fully.

### Removing a Readi-Reel

1. To remove a Readi-Reel from the an adapter, depress the retaining spring with a thumb while pulling the Readi-Reel cage from the adapter with both hands. Do not remove the adapter from the spindle.

FIGURE A.9

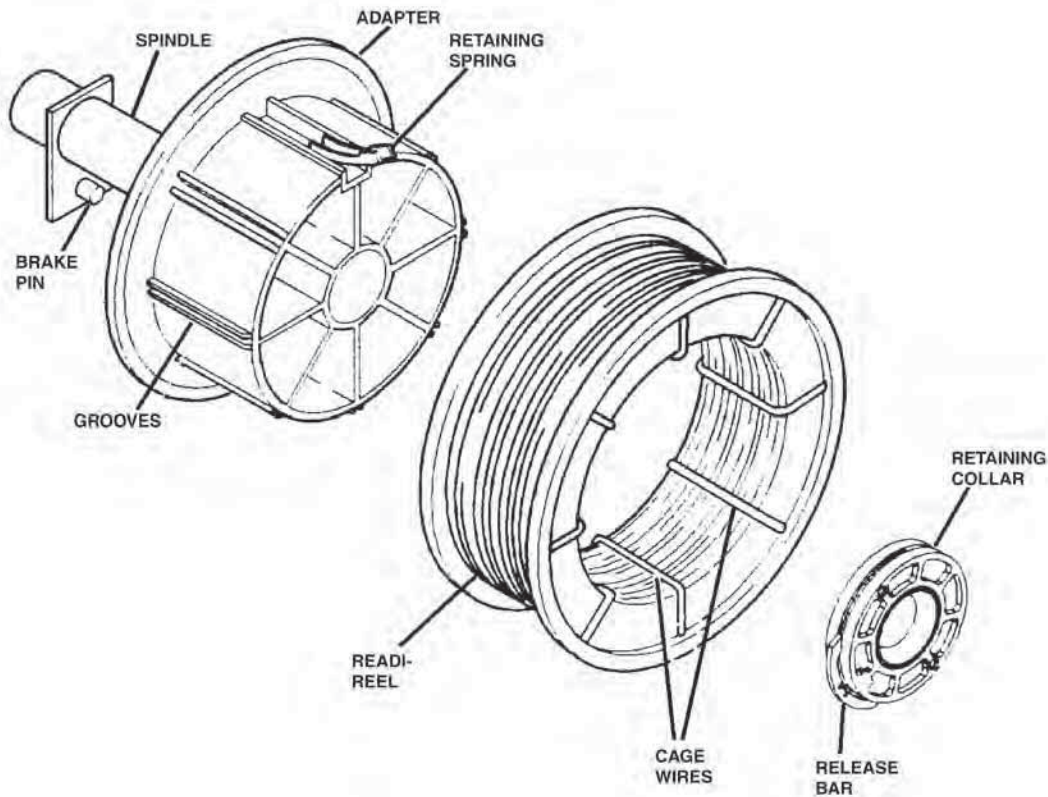

## WELD WIRE ROUTING

The electrode supply may be either from reels, Read-Reels, spools, or bulk packaged drums or reels. Observe the following precautions:

- a) The electrode must be routed to the wire drive unit so that the bends in the wire are at a minimum, and also that the force required to pull the wire from the reel into the wire drive unit is kept at a minimum.
- b) The electrode is "hot" when the gun trigger is pressed and must be insulated from the boom and structure.
- c) If more than one wire feed unit shares the same boom and are not sharing the same power source output stud, their wire and reels must be insulated from each other as well as insulated from their mounting structure.

## SHIELDING GAS CONNECTION



**CYLINDER may explode if damaged.**

- Keep cylinder upright and chained to support.
- Keep cylinder away from areas where it may be damaged.
- Never lift welder with cylinder attached.
- Never allow welding electrode to touch cylinder.
- Keep cylinder away from welding or other live electrical circuits.



**BUILD-UP OF SHIELDING GAS may harm health or kill.**

- Shut off shielding gas supply when not in use.

SEE AMERICAN NATIONAL STANDARD Z-49.1, "SAFETY IN WELDING AND CUTTING" PUBLISHED BY THE AMERICAN WELDING SOCIETY.

Maximum inlet pressure is 100 psi. (6.9 bar.)

Install the shielding gas supply as follows:

1. Secure the cylinder to prevent it from falling.
2. Remove the cylinder cap. Inspect the cylinder valves and regulator for damaged threads, dirt, dust, oil or grease. Remove dust and dirt with a clean cloth. **DO NOT ATTACH THE REGULATOR IF OIL, GREASE OR DAMAGE IS PRESENT!** Inform your gas supplier of this condition. Oil or grease in the presence of high pressure oxygen is explosive.
3. Stand to one side away from the outlet and open the cylinder valve for an instant. This blows away any dust or dirt which may have accumulated in the valve outlet.
4. Attach the flow regulator to the cylinder valve and tighten the union nut(s) securely with a wrench. Note: If connecting to 100% CO<sub>2</sub> cylinder, insert regulator adapter between regulator and cylinder valve. If adapter is equipped with a plastic washer, be sure it is seated for connection to the CO<sub>2</sub> cylinder.
5. Attach one end of the inlet hose to the outlet fitting of the flow regulator. Attach the other end to the welding system shielding gas inlet. Tighten the union nuts with a wrench.
6. Before opening the cylinder valve, turn the regulator adjusting knob counterclockwise until the adjusting spring pressure is released.
7. Standing to one side, open the cylinder valve slowly a fraction of a turn. When the cylinder pressure gage stops moving, open the valve fully.
8. The flow regulator is adjustable. Adjust it to the flow rate recommended for the procedure and process being used before making a weld.

## INSTALLING ELECTRODE CONDUIT KITS

### ⚠ WARNING



**ELECTRIC SHOCK can kill.**

- Turn the input power OFF at the disconnect switch before working on this equipment.
- Do not touch electrically hot parts.

Electrode conduit is used when feeding wire drums, from boxes or large reels. For best feeding results, use the shortest conduit length possible and avoid sharp bends.

**(For Codes 11075, 11076, 11077)**

Tools required: (See Figure A.10a)

- Snap Ring Pliers

To install Lincoln conduit:

1. Turn off power at the welding power source.
2. Remove the snap ring holding the ball bushing assembly to the back of the wire feeder. Remove the ball bushing assembly.

FIGURE A.10a

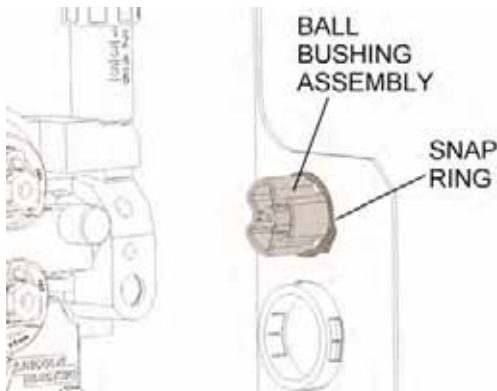

**(For Codes 11209, 11210, 11211 and above)**

To install Lincoln conduit: (See Figure A.10b)

1. Turn off power at the welding power source.
2. Remove the "O" ring holding the ball bushing assembly to the back of the wire feeder. Remove the ball bushing assembly.

FIGURE A.10b

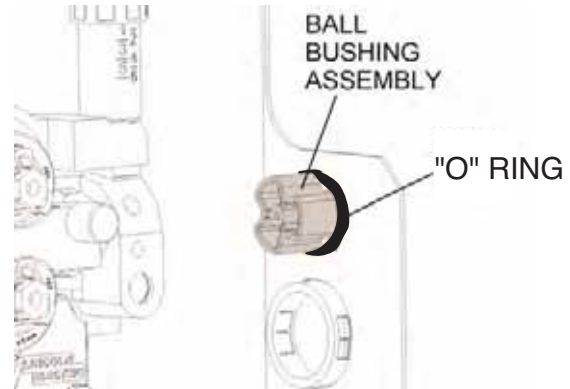

3. Place a K1546-xx conduit connector into the back of the wire drive. Rotate the conduit connector to a position where the thumb screw does not interfere with the idle arm or door.
4. Tighten the set screw to secure the conduit connector in the wire drive.
5. Insert conduit through the sheet metal of the LF-72 and into the conduit connector. Secure with the thumb screw.

FIGURE A.11

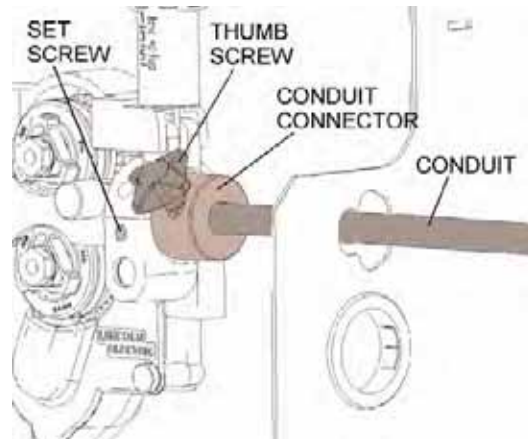

## ALUMINUM WIRE PREPARATIONS

### ⚠ WARNING



**ELECTRIC SHOCK can kill.**

- Turn the input power OFF at the disconnect switch before working on this equipment.
- Do not touch electrically hot parts.

Welding with aluminum filler wires requires extra care. Aluminum wire is softer and not as stiff as steel wires, it is important to keep aluminum wire free of dirt and scratches. Limit gun length to 10 Ft.(3.0 m) for best results and use a spool cover if feeding from a spool.

To prevent scratching of the aluminum wire, remove the ball bearings from the ball housing as follows.

**(For Codes 11075, 11076, 11077)**

Tools required: (See Figure A.12a)

- Snap Ring Pliers
- 9/64" Hex key wrench

1. Turn off power at the welding power source.
2. Remove the snap ring holding the ball bushing assembly to the back of the wire feeder. Remove the ball bushing assembly.

FIGURE A.12a

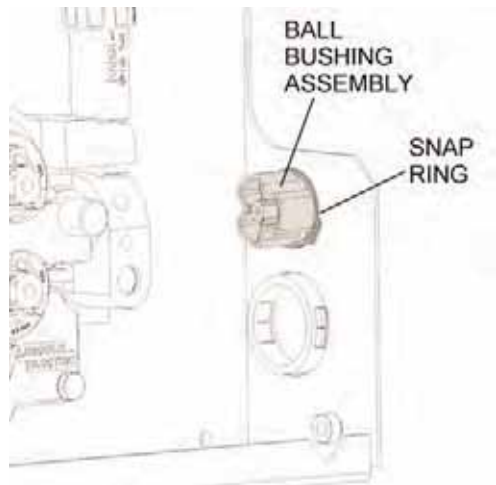

**(For Codes 11209, 11210, 11211 and above)**

Tools required: (See Figure A.12b)

- 9/64" Hex key wrench

1. Turn off power at the welding power source.
2. Remove the snap ring holding the ball bushing assembly to the back of the wire feeder. Remove the ball bushing assembly.

FIGURE A.12b

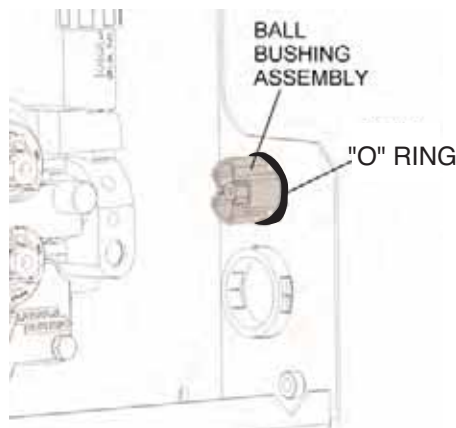

3. Remove the three socket head cap screws from the ball bushing assembly. **Caution: as the screws are being loosened, the balls may fall free from the assembly.** Remove the balls and the steel washer.

FIGURE A.13

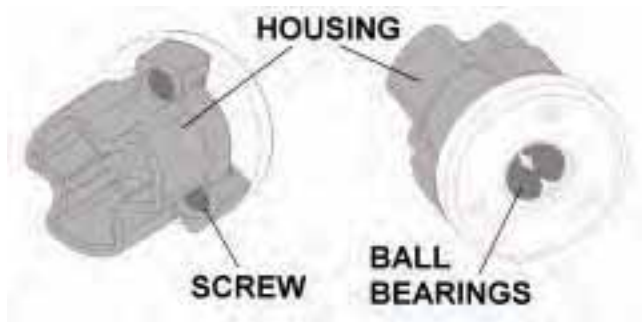

4. Place the ball bushing housing into the wire feeder case and secure with the snap ring or "O" ring depending on which code your machine uses.



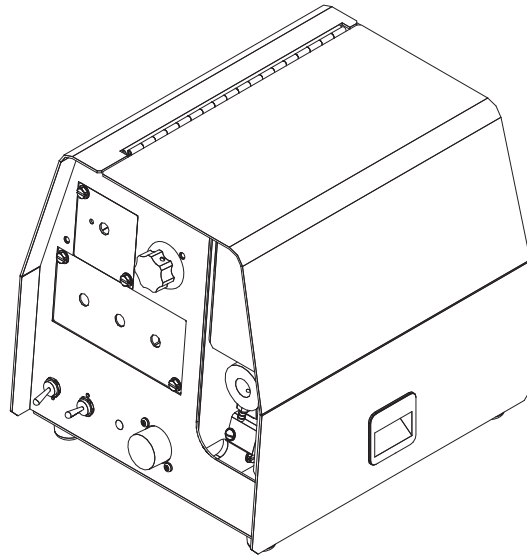

**BENCH MODEL STANDARD DUTY**

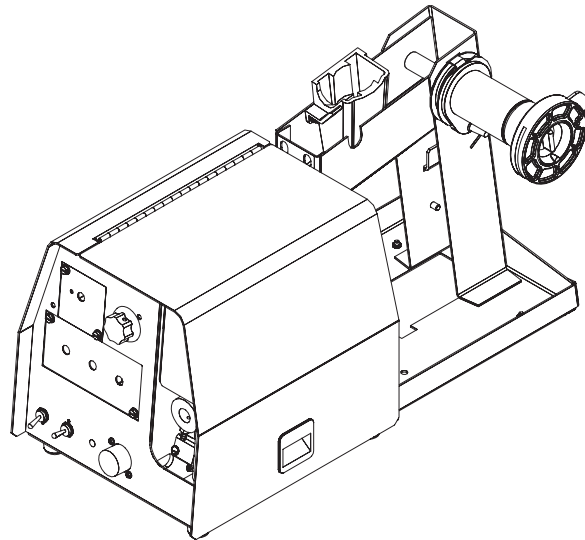

**BENCH MODEL HEAVY DUTY**

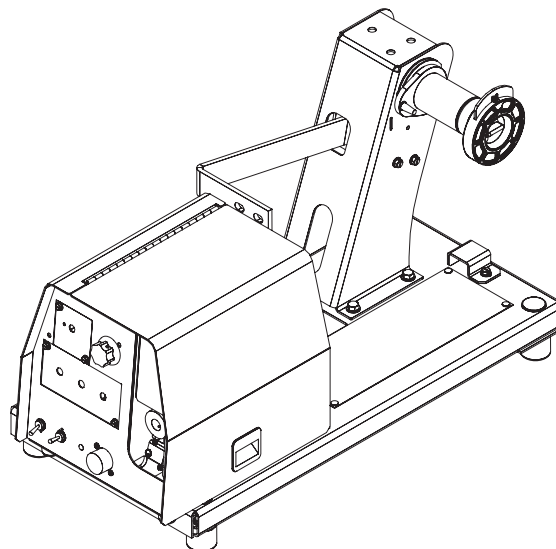

## TYPICAL SYSTEM CONFIGURATIONS

The LF-72 is capable of welding with many different welding processes. These processes may require reconfiguring the LF-72 with other products that may or may not be included with the model you purchased. Use the Table 1 and 2 below to identify the basic items which are included in the LF-72 to utilize the various Welding Processes that the machine is capable of controlling.

**TABLE 1**

PART NO.	Description	Wire Feeder	Gun	Wire Reel Stand	Drive Roll Kit	CONTROL CABLE
K2327-1	Base Model	LF-72	15', <b>Magnum 400</b> , .035-.045 (0.9-1.2 mm)	---	.035-.045 combo (0.9-1.2 mm)	10' (3m)
K2327-2	Bench Model, Standard Duty			Standard duty, up to 44 lb. (20 kg) spools.		
K2327-3	Bench Model, Heavy Duty			Heavy Duty, up to 60 lb. (27.2 kg) coils.		

**TABLE 2**

PART NO.	Description	Wire Feeder	Gun	Wire Reel Stand	Drive Roll Kit	CONTROL CABLE
K2327-4	Base Model	LF-72	15', <b>Magnum Pro 350</b> .035-.045 (0.9-1.2 mm)	---	.035-.045 combo (0.9-1.2 mm)	10' (3m)
K2327-5	Bench Model, Standard Duty			Standard duty, up to 44 lb. (20 kg) spools.		
K2327-6 K2327-7	Bench Model, Heavy Duty			Heavy Duty, up to 60 lb. (27.2 kg) coils.		

LF-72



### SAFETY PRECAUTIONS

Read this entire section of operating instructions before operating the machine.

#### **WARNING**



#### **ELECTRIC SHOCK can kill.**

- Unless using cold feed feature, when feeding with the gun trigger, the electrode and drive mechanism are always electrically energized and could remain energized several seconds after welding ceases.
- Do not touch electrically live parts or electrodes with your skin or wet clothing.
- Insulate yourself from the work and ground.
- Always wear dry insulating gloves.

ONLY QUALIFIED PERSONS SHOULD INSTALL, USE OR SERVICE THIS EQUIPMENT. READ AND FOLLOW THE MANUFACTURER'S INSTRUCTIONS, EMPLOYER'S SAFETY PRACTICES AND MATERIAL SAFETY DATA SHEETS (MSDS) FOR CONSUMABLES.

READ THIS WARNING, PROTECT YOURSELF & OTHERS.

#### **FUMES AND GASES can be dangerous.**



- Keep your head out of fumes.
- Use ventilation or exhaust at the arc, or both, to keep fumes and gases from your breathing zone and general area.

#### **WELDING SPARKS can cause fire or explosion.**



- Do not weld near flammable material.
- Do not weld on containers which have held flammable material.

#### **ARC RAYS can burn.**



- Wear eye, ear, and body protection.

Observe additional guidelines detailed in the beginning of this manual.

The serviceability of a product or structure utilizing the LF-72 wire feeder is and must be the sole responsibility of the builder/user. Many variables beyond the control of The Lincoln Electric Company affect the results obtained in using the LF-72 wire feeder. These variables include, but are not limited to, welding procedure, plate chemistry and temperature, weldment design, fabrication methods and service requirements. The available range of the LF-72 wire feeder may not be suitable for all applications, and the builder/user is and must be solely responsible for welding settings.

#### **GRAPHIC SYMBOLS THAT APPEAR ON THIS MACHINE OR IN THIS MANUAL**



**COLD FEED**



**POSITIVE OUTPUT**



**NEGATIVE OUTPUT**



**PROTECTIVE GROUND**



**WARNING OR CAUTION**



**DANGEROUS VOLTAGE**



**SHOCK HAZARD**



**WELDING FUMES**



**EXPLOSION**



**GAS INPUT**



**WORK CONNECTION**

## COMMON WELDING ABBREVIATIONS

### WFS

- Wire Feed Speed

### CV

- Constant Voltage

### GMAW (MIG)

- Gas Metal Arc Welding

### FCAW (Cable Innershield or Outershield)

- Flux Core Arc Welding

## PRODUCT DESCRIPTION

### General Physical Description

The LF-72 is optimized for .035 through .045 (0.9mm through 1.2mm) GMAW welding. The powerful 2 roll drive, heavy duty enclosure and wire reel stand combine to make an easy to install, easy to use wire feeder for everyday welding. Powering the wire drive is a high performance motor gearbox. A heavy duty hinged door opens easily, which provides an ample amount of room for assembling precision drive components and the welding gun. Also under the door is a convenient storage tray for contact tips and tools.

Three packages are available. The basic unit consists of the wire drive box housing. The standard duty bench model targets users of 12" (305 mm) diameter spools. The heavy duty bench model satisfies the needs of customers using 60 lb (27.2 kg) spools.

### General Functional Description

- The LF-72 is a highly versatile and economical choice of industrial feeders. Easy to use features are a calibrated WFS knob, cold-feed/ gas purge switch and trigger interlock.
- Several kits are available to expand the LF-72's welding capability. The timer kit allows adjustment of burnback and postflow times. The remote voltage control kit includes a 0 to 10 dial for setting the welding voltage at the wire feeder. The swivel kit mounts to the lift bail of a power source and lets the feeder freely rotate so the gun cable stays straight.

## RECOMMENDED PROCESSES

- GMAW .023-1/16 (0.6 - 1.6 mm) steel electrodes.
- FCAW .035 -5/64 (0.9 - 2.0mm) cored electrodes

## PROCESS LIMITATIONS

- Rated for up to 1/16(1.6 mm) solid electrode and 5/64 (2.0 mm) cored electrode.
- The maximum WFS is 800 in/min (20.3 M/min).
- The LF-72 is not recommended for GMAW-Pulse (synergic), GTAW, GTAW-Pulse, SAW, CAG, SMAW.
- Do not use push-pull equipment with the LF-72.
- For K2327-2, -5 Bench model, std. duty: Maximum spool size = 44 lb. (20 kg); 12 inch (300mm) diameter; 4 inch (100mm)
- For K2327-3, -6, -7 Bench model, heavy duty: Maximum spool size = 60 lb. (27.2 kg)

## REQUIRED EQUIPMENT

Lincoln's LF-72 is designed for use with the CV and DC family of power sources. These include:

- CV-305
- CV-400
- CV-655
- DC-400
- DC-600
- Invertec™ V350
- Invertec™ V450

## EQUIPMENT LIMITATIONS

- Maximum gun length =25 ft. (7.6m)
- Maximum conduit length = 30 ft. (9.1m)
- Maximum total control cable length = 100ft (31m)
- The LF-72 operates on 42VAC and not 115 VAC
- The K1733-1 wire straightener may not be used with the LF-72
- Gun bushings are required for welding guns that do not have a Magnum (Tweco #2-#4 compatible) back end.
- The LF-72 does not attach to K303 wire reel stands.

## FRONT PANEL CONTROLS AND CONNECTIONS

## CASE FRONT CONTROLS

FIGURE B.1

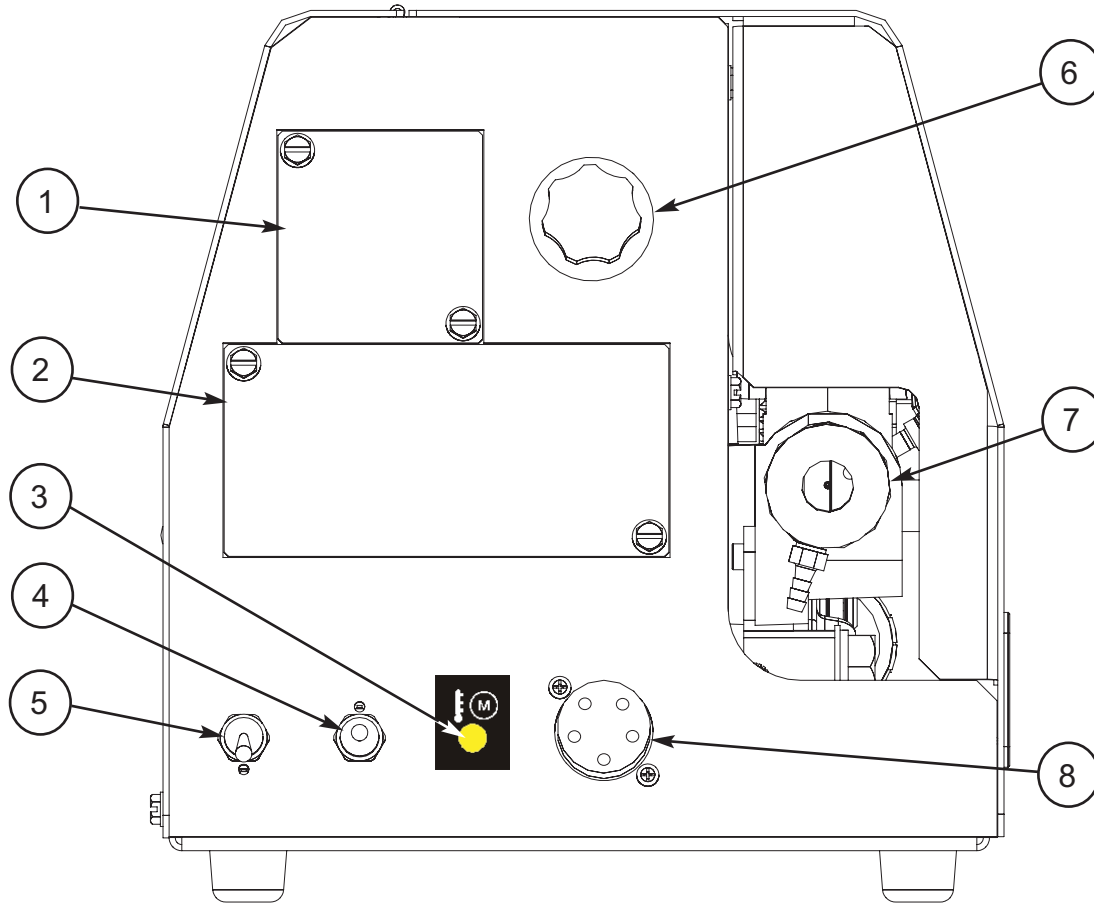

ITEM	DESCRIPTION
1	Location for <b>Optional</b> Remote Voltage Control ( <b>See Accessory Section For Kit Number</b> ).
2	Location for <b>Optional</b> Burnback and Postflow Timer Kit ( <b>See Accessory Section For Kit Number</b> ).
3	Thermal LED, Motor Overload.
4	Cold Feed - Gas Purge Switch, press the switch up to feed wire with weld output off. Press the switch down for gas flow with weld output off.
5	2 step - Trigger Interlock switch.
6	Wire Feed Speed Knob.
7	Gun Receiver Bushing.
8	Trigger Connector 5-pin amphenol for connecting the MIG gun trigger. See Installation Section for detail.

## 1. REMOTE VOLTAGE CONTROL KIT

The **optional** remote voltage control kit adjusts the arc voltage from the minimum to the maximum voltage of the welding power source. Rotate the knob counterclockwise to reduce the arc voltage and rotate the knob clockwise to raise the arc voltage.



## 2. BURNBACK AND POSTFLOW TIMER KIT

The **optional** Burnback and Postflow Timer Kit gives control over the shielding gas at the end of the weld and prepares the end of the wire for the next arc start. Additional shielding gas protection is often required when welding aluminum, stainless steel or exotic alloys.

When stitch welding, set the postflow time to maximum for best results.

### Burnback Timer

The burnback timer range is OFF to 0.25 seconds. The burnback timer controls the additional amount of time the power source output remains ON after the wire drive has stopped feeding wire. Burnback adjustment prevents the wire from sticking to the weld at the end of a weld and helps to condition the wire for the next weld.

To set the burnback time, adjust the knob to approximately 0.03 seconds and then decrease or increase the time as desired.

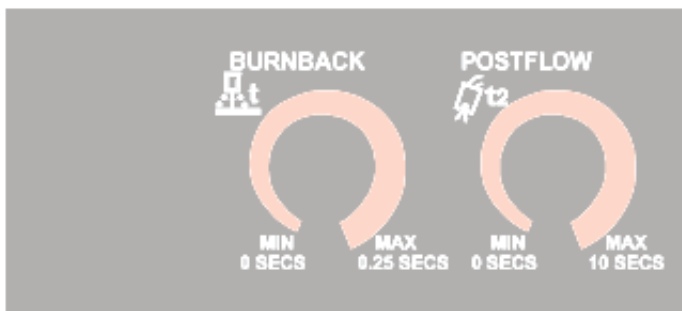

### Postflow Timer

The postflow timer range is OFF to 10 seconds. Postflow is the time from when the power source output turns OFF until the postflow timer expires. Use postflow to protect the weld while the weld cools.

## 3. THERMAL LED, MOTOR OVERLOAD

The thermal light illuminates when the wire drive motor draws too much current. If the thermal light illuminates, the wire drive will automatically shutdown for up to 30 seconds to allow the motor to cool. To start welding again, release the gun trigger, inspect the gun cable, liner (and conduit). Clean and make repairs as necessary. Start welding again when the problem has been safely resolved.

For best results, keep the gun cable and conduit as straight as possible. Perform regular maintenance and cleaning on the gun liner, conduit and gun. Always use quality electrode, such as L-50 or L-56 from Lincoln Electric.

## 4. COLD FEED/GAS PURGE SWITCH

Cold Feed and Gas Purge are combined into a single spring centered toggle switch.

To activate Cold Feeding, hold the switch in the UP position. The wire drive will feed electrode but neither the power source nor the gas solenoid will be energized. Adjust the speed of cold feeding by rotating the WFS knob. Cold feeding, or "cold inching" the electrode is useful for threading the electrode through the gun.



Hold with toggle switch in the DOWN position to activate Gas Purge and let the shielding gas flow. The gas solenoid valve will energize but neither the power source output nor the drive motor will be turned on. The Gas Purge switch is useful for setting the proper flow rate of shielding gas. Flow meters should always be adjusted while the shielding gas is flowing.

## 5. 2 STEP - TRIGGER INTERLOCK SWITCH

The 2 Step - Trigger Interlock switch changes the function of the gun trigger. 2 Step trigger operation turns welding on and off in direct response to the trigger. Trigger Interlock operation allows welding to continue when the trigger is released for comfort on long welds.



Place the toggle switch in the DOWN position for 2 Step operation or in the UP position for Trigger Interlock operation.

### 2 Step Trigger

2 Step trigger operation is the most common. When the gun trigger is pulled, the welding power source energizes the electrode output and the wire feeder feeds wire for welding. The power source and wire feeder continue welding until the trigger is released.

## Trigger Interlock

Trigger Interlock operation provides for operator comfort when making long welds. When the gun trigger is first pulled, the welding power source energizes the output and the wire feeder feeds wire for welding. The gun trigger is then released while the weld is made. To stop welding, the gun trigger is pulled again, and when it is released the welding power source output turns off and the wire feeder stops feeding wire.



### CAUTION



- If the arc goes out while welding with trigger interlock operation, the electrode output from the welding power source remains energized and the wire feeder will continue to feed wire until the gun trigger is again pulled and then released.

## 6. WIRE FEED SPEED KNOB

The large, calibrated wire feed speed knob makes for easy and accurate adjustment of the wire feed speed. The knob rotates 3/4 turn. Turn the knob clockwise to increase the wire feed speed, and counter clockwise to reduce the wire feed speed.

The wire feed speed range is 50 to 800 in/min (1.27 - 20.3 m/min).

## 7. GUN RECEIVER BUSHING (K1500-2)





(K1500-2 bushing is standard on all LF-72's)

This Gun Receiver Bushing is used with Lincoln gun connectors, also with Magnum 200/300/400 guns and compatible with Tweco® #4).

## 8. TRIGGER CONNECTOR 5-PIN AMPHENOL

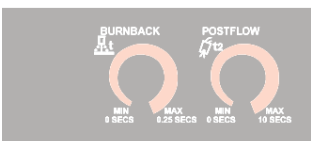









This is used for connecting the MIG gun trigger. See Installation Section for detail.

## OPTIONAL KITS:











K2329-1	Remote Voltage Control Kit.	Includes: 10k potentiometer, harness, knob and decal with a 0-10 scale and mounting hardware.	
K2330-1	Timer Kit.	Includes: Panel and harness for adjusting burnback and postflow times.	
K2328-1	Standard Duty Wire Reel Stand.	Includes: Wire Reel Stand for up to 44 lbs (20 kg) spools, Spindle and mounting hardware.	
K2331-1	Lift Bail Kit.	Includes: Insulated lift bail and hardware.	
K2332-1	Swivel Kit. (for use with Standard Duty Bench Models)	Includes: Swivel adapter and mounting hardware for attaching to a power source lift bale.	
K1796-xx	Co-Axial Power Cable.	Includes: Coaxial weld cable of length "xx". Ends of the weld cable have lug connections. Use for Pulse or STT welding.	
K1803-1	Work and Feeder Cables Package.	Includes: Twist-Mate to Lug 2/0 cable 14' (1.2m) long with Ground Clamp, and Twist-Mate to Lug 2/0 Cable 9' (2.7m) long.	
K1840-xx	Weld Power Cable, Twist-Mate to Lug.	Includes: Twist-Mate to Lug, 1/0 cable of length "xx".	
K1841-xx	Weld Power Cable, Twist-Mate to Twist-Mate.	Includes: Twist-Mate to Twist-Mate, 1/0 Cable for 25' (7.6m) cables. Includes: Twist-Mate to Twist-Mate, 2/0 Cable for 50' (15.2m) cables.	
K1842-xx	Weld Power Cable, Lug to Lug.	Includes: Lug to Lug, 3/0 Cable of length "xx" for lengths up to 60' (18.3m). Lug to Lug, 4/0 Cable of length "xx" for lengths greater than 60' (18.3m).	



## OPTIONAL KITS:

K1797-xx	Control Cable.	Includes: 14 pin to 14 pin wire feeder to power source control cable.	
K2335-1	Adapter for Miller Power Sources.	Includes: Adapter control cable for connecting a Lincoln 42 VAC wire feeder to a 24 VAC Miller power source.	
K1520-1	42 Volt Transformer Kit.	Includes: One transformer kit for operating a 42 VAC wire feeder on a power source supplying only 115 VAC.	
K1798	Adapter Cable for Control Cable to Terminal Strip Power Sources.	Includes:	
K910-1	Ground Clamp.	Includes: One 300 Amp Ground Clamp.	
K910-2	Ground Clamp.	Includes: One 500 Amp Ground Clamp.	
K1500-1	Gun Receiver Bushing (for guns with K466-1 Lincoln gun connectors; Innershield and Subarc guns.)	Includes: Gun receiver bushing, set screw and hex key wrench.	
K1500-2 (standard on all LF-72's)	Gun Receiver Bushing (for guns with K466-2, K466-10 Lincoln gun connectors; Magnum 200/300/400 guns and compatible with Tweco® #4.)	Includes: Gun receiver bushing with hose nipple, set screw and hex key wrench.	
K1500-3	Gun Receiver Bushing (for guns with K613-7 Lincoln gun connectors; Magnum 550 guns and compatible with Tweco® #5.)	Includes: Gun receiver bushing with hose nipple, set screw and hex key wrench.	
K1500-4	Gun Receiver Bushing (for gun with K466-3 Lincoln gun connectors; compatible with Miller® guns.)	Includes: Gun receiver bushing with hose nipple, set screw and hex key wrench.	
K1500-5	Gun Receiver Bushing (compatible with Oxo® guns.)	Includes: Gun receiver bushing with hose nipple, 4 guide tubes, set screw and hex key wrench.	

## OPTIONAL KITS:

K489-7	Gun Receiver Bushing (for Lincoln Fast-Mate guns.)	Includes: Gun receiver bushing with trigger connector.	
K466-2	Magnum 200/300/400 to K1500-2 Adapter.	Includes: Gun adapter, cotter pin, hex key wrench, wrench.	
K613-7	Magnum 550 to K1500-3 Adapter Lincoln Conduit.	Includes: Trigger adapter, gun adapter and hex key wrench.	
K1546-1	Incoming Bushing, for Lincoln Conduit .025- 1/16" (0.6 - 1.6mm) wire.	Includes: Incoming bushing and hex key wrench.	
K1546-2	Incoming Bushing, for Lincoln Conduit 1/16-1/8" (1.6 - 3.2 mm) wire.	Includes: Incoming bushing and hex key wrench.	
K435	Spindle Adapter, for mounting 14 lb. (6.4 kg) Innershield Coils on 2 in (51 mm) spindles.	Includes: Spindle Adapter made from 2 coil retainers. (Electrode not included.)	
K468	Spindle Adapter, for mounting 8in (203mm) diameter spools on 2 in (51 mm) spindles.	Includes: Spindle Adapter.	
K363P	Readi-Reel Adapter, for mounting 23-30 lb. (10.4 - 13.6 kg) reels to 2 in (51 mm) spindles.	Includes: Readi-Reel spool adapter. (Spool of electrode not included.)	
K438	Readi-Reel Adapter, for mounting 50-60 lb. (22.7 - 27.2 kg) reels to 2 in (51 mm) spindles. For use with Heavy Duty Bench models.	Includes: Readi-Reel spool adapter. (Spool of electrode not included.)	
K1504-1	Coil Adapter, for mounting 50-60 lb. (22.7 - 27.2 kg) coils to 2 in (51 mm) spindles. For use with heavy Duty Bench models.	Includes: 50-60 lb. (22.7 - 27.2 kg) coil adapter.	

## OPTIONAL KITS:

K1634-1	Plastic Wire Cover for 30-44 lb. (13.6 - 20.0 kg) Wire packages. (For use with Standard Duty Bench Models and Heavy Duty Bench Models.)	Includes: Cover, backing plate, wire conduit, incoming bushing for .025 - 1/16" (0.6 - 1.6 mm) wire, incoming bushing for 1/16" - 1/8" (1.6 - 3.2 mm) wire, thumb screw, mounting hardware and hex key.	
K1634-2	Plastic Wire Cover for up to 60 lb. (27.2kg) Wire packages. (For use with Heavy Duty Bench Models.)		
K659-1	Gas Guard Regulator	Includes: Gas Guard Regulator and adjustment key.	
3000290	Adjustable Gas Regulator	Includes: Gas Regulator for Mixed Gases and 10' (3.0m) Hose.	
K586-1	Deluxe Adjustable Gas Regulator	Includes: Deluxe Gas Regulator for Mixed Gases, Adapter for CO2 and 10' (3.0m) Hose.	
K1524-3	Heavy Duty Universal Wire Reel Stand. For spools up to 60 lb. (27.2kg)	Includes: Heavy Duty Wire Reel Stand.	
K163	4 Wheeled Wire Feeder Undercarriage (For use with Standard Duty Bench Models and Heavy Duty Bench Models.)	Includes: Undercarriage with 8" (203mm) rear wheels, 4" (102mm) casters.	
K1557-1	Swivel Platform (for use with Heavy Duty Bench Models)	Includes: Swivel Platform and Tray.	
K1556-1	Light Duty Caster Kit (for use with Heavy Duty Bench Models)	Includes: 2 Swivel Casters, 2 Fixed Casters, brackets and mounting hardware.	
K1555-1	Insulated Lift Bail (for use with Heavy Duty Bench Models)	Includes: Insulated Lift Bail and mounting hardware.	

## MAINTENANCE

### Safety Precautions

#### ⚠ WARNING



ELECTRIC SHOCK can kill.

- Do not touch electrically live parts such as output terminals or internal wiring.
- When inching with gun trigger, electrode and drive mechanism are “hot” to work and ground and could remain energized several seconds after the gun trigger is released.
- Turn OFF input power at welding power source before installation or changing drive roll and/or guide tubes.
- Welding power source must be connected to system ground per the National Electrical Code or any applicable local codes.
- Only qualified personnel should perform maintenance work.

Observe all additional Safety Guidelines detailed throughout this manual.

### ROUTINE MAINTENANCE

- Clean and tighten all weld terminals.
- Inspect all weld cables, control cables, gun cables and shielding gas hoses. Repair or replace as necessary.

### PERIODIC MAINTENANCE

- Clean drive roll grooves.
- Blow out or vacuum the inside of the feeder.

## CALIBRATION SPECIFICATION

#### ⚠ WARNING



ELECTRIC SHOCK can kill.

- Do not touch electrically live parts.
- When inching with the gun trigger, electrode, wire drive motor and drive mechanism are “hot” to work and ground and could remain energized several seconds after the gun trigger is released.
- Welding power source must be connected to system ground per the National Electrical Code or any applicable local codes.
- Only qualified personnel should perform maintenance work.

Calibration of the LF-72 may be required when the p.c. board, potentiometer or motor is replaced or serviced. Calibration matches the scale on the name plate to the actual wire feed speed.

To verify if calibration is necessary:

1. Turn off power to the LF-72.
2. Assemble .045 drive rolls, inner guide and the outer guide into the drive. Remove the gun from the wire feeder if assembled.
3. Load .045 wire into the drive. Cut the wire flush with the end of the gun bushing.
4. Set the WFS knob to 300 ipm.
5. Using the COLD FEED switch, feed wire for 10 seconds.
6. Cut the wire flush with the end of the gun bushing. Measure the length of the wire. If the wire measures  $50 \pm 2.5$  inches then calibration is not required.

Tools required applies to all codes that follow:

- 5/16" nut driver
- 3/4" open end wrench
- WFS meter or RPM meter
- Shorting plug. The shorting plug shorts pins 1 & 5 of connector J2 on the p.c. board. J2 is a 6 pin molex connector.

To calibrate the LF-72 for Codes 11075 thru 11293:

1. Turn off power to the LF-72.
2. Disconnect the electrode lead from the feed plate and from the welding power source.
3. Remove the 5 screws securing the wraparound. (The door is not shown for clarity. “See Figure D.1”)
4. Open the idle arm.
5. Turn power on to the LF-72.

FIGURE D.1

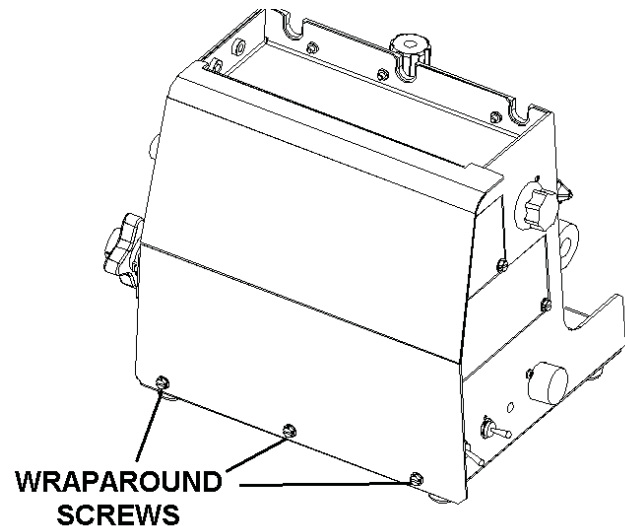
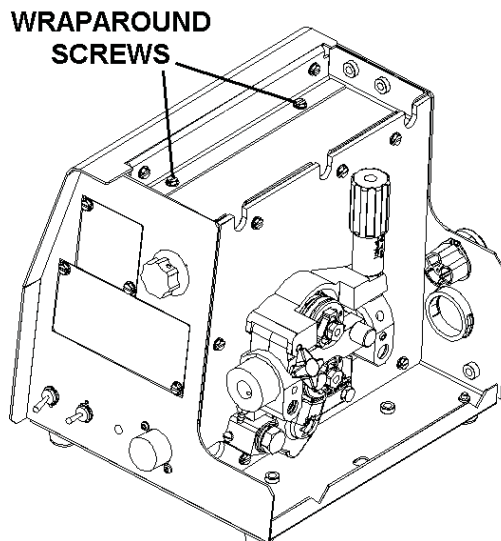

6. Adjust the WFS knob to 300 ipm. Center the knob pointer with the name plate graphics. Activate the gun trigger.
7. Insert the shorting plug into connector J2 on the p.c. board. The shorting plug shorts pins 1 & 5. **(See Figure D.2)**
8. Remove the shorting plug. Set aside.

**(For Codes below 11289 use 9 thru 17)**

9. Adjust the WFS knob to minimum.
10. Insert the shorting plug into connector J2.
11. Adjust the WFS knob until the motor measures  $51 \pm 5.5$  ipm. ( $9.5 \pm 1.0$  rpm).
12. Remove the shorting plug.
13. Adjust the WFS knob to maximum.
14. Insert the shorting plug into connector J2.
15. Adjust the WFS until the motor measures  $793 \pm 5.5$  ipm ( $146.7 \pm 1.0$  rpm.)
16. Remove the shorting plug.
17. Release the gun trigger.

**(For Codes above 11290 use 18)**

18. Replace P2 from the harness into connector J2.
19. Turn off power.
20. Secure the wraparound to the LF-72 with 5 screws.

**To calibrate the LF-72 for Codes 11606 thru 11609:**

1. Turn off power to the LF-72 and welding power source.
2. Disconnect the electrode lead from the feed plate and from the welding power source.
3. Remove the wraparound from the LF-72, See **Figure D.1**.
4. Set WFS Knob to 50 IPM and trigger the machine.
5. Measure drive role RPM. If reading is 8.9 to 9.2 RPM proceed to step 6 otherwise insert the shorting plug into the control p.c. board J2 (shorts pins 1 and 5.) See Figure D.2 and adjust WFS Knob to get  $9.05 \pm 0.15$  RPM and then remove shorting plug.

6. Set WFS Knob to 300 IPM.
7. Measure drive role RPM. If reading is 54.8 to 56.0 RPM proceed to step 8 otherwise insert the shorting plug into the control p.c. board J2 (shorts pins 1 and 5.) **See Figure D.2** and adjust WFS Knob to get  $55.4 \pm 0.6$  RPM and then remove the shorting plug.
8. Set WFS Knob to 800 IPM.
9. Measure drive role RPM. If reading is 146.4 to 148.4 RPM calibration is complete otherwise insert the shorting plug into the control p.c. board J2. (shorts pins 1 and 5.) **See Figure D.2** and adjust WFS Knob to get  $147.4 \pm 1.0$  RPM and then remove the shorting plug. Release the Gun Trigger, connect J2 of the harness to p.c. board.

FIGURE D.2

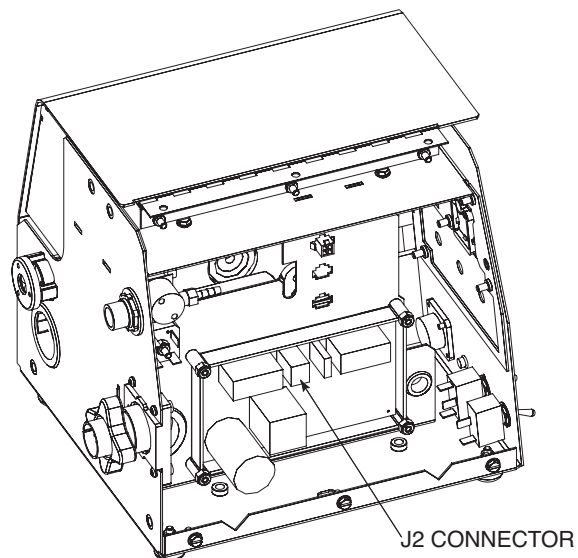

**⚠ WARNING**

ELECTRIC SHOCK can kill.



- Turn the input power OFF at the welding power source before installation or changing drive rolls and/or guides.
- Do not touch electrically live parts.
- When inching with the gun trigger, electrode and drive mechanism are "hot" to work and ground and could remain energized several seconds after the gun trigger is released.
- Welding power source must be connected to system ground per the National Electrical Code or any applicable local codes.
- Only qualified personnel should perform maintenance work.

Observe all additional Safety Guidelines detailed throughout this manual.

## HOW TO USE TROUBLESHOOTING GUIDE

Service and Repair should only be performed by Lincoln Electric Factory Trained Personnel. Unauthorized repairs performed on this equipment may result in danger to the technician and machine operator and will invalidate your factory warranty. For your safety and to avoid Electrical Shock, please observe all safety notes and precautions detailed throughout this manual.

This Troubleshooting Guide is provided to help you locate and repair possible machine malfunctions. Simply follow the three-step procedure listed below.

### **Step 1. LOCATE PROBLEM (SYMPTOM).**

Look under the column labeled "PROBLEM (SYMPTOMS)". This column describes possible symptoms that the machine may exhibit. Find the listing that best describes the symptom that the machine is exhibiting.

### **Step 2. POSSIBLE CAUSE.**

The second column labeled "POSSIBLE CAUSE" lists the obvious external possibilities that may contribute to the machine symptom.

### **Step 3. RECOMMENDED COURSE OF ACTION**

This column provides a course of action for the Possible Cause, generally it states to contact your local Lincoln Authorized Field Service Facility.

If you do not understand or are unable to perform the Recommended Course of Action safely, contact your local Lincoln Authorized Field Service Facility.

**⚠ CAUTION**

If for any reason you do not understand the test procedures or are unable to perform the tests/repairs safely, contact your **Local Lincoln Authorized Field Service Facility** for technical troubleshooting assistance before you proceed.

Observe all Safety Guidelines detailed throughout this manual

PROBLEMS (SYMPTOMS)	POSSIBLE AREAS OF MISADJUSTMENTS(S)	RECOMMENDED COURSE OF ACTION
<b>OUTPUT PROBLEMS</b>		
The wire feeder does not feed wire and the drive rolls do not spin.	<ol style="list-style-type: none"> <li>1. Verify the power source is turned on.</li> <li>2. Verify the circuit breaker for the wire feeder on the power source has not tripped.</li> <li>3. Check that the gun trigger is operating properly.</li> <li>4. If the motor thermal LED is illuminated, wait approximately 1 minute before welding again. Inspect the gun for feeding problems.</li> <li>5. Verify power is being supplied to the wire feeder.</li> </ol>	<p>If all recommended possible areas of misadjustment have been checked and the problem persists, <b>Contact your local Lincoln Authorized Field Service Facility.</b></p>
The wire feeds erratically, or the Motor Thermal LED lights.	<ol style="list-style-type: none"> <li>1. Verify the correct drive rolls and inner wire guide are installed in the wire drive.</li> <li>2. Check for sharp bends in the gun liner.</li> <li>3. Examine the contact tip for wear and proper size. Replace as necessary.</li> <li>4. Check the gun liner. The welding electrode should slide easily through the gun.</li> <li>5. Verify the proper gun liner is installed.</li> <li>6. Adjust the pressure arm.</li> <li>7. On bench models, make sure the brake tension is not too tight.</li> <li>8. If using a wire conduit, verify the wire slides easily through the conduit.</li> </ol>	
The wire continues to feed when the trigger is released.	<ol style="list-style-type: none"> <li>1. Check if the 2 step/Trigger Interlock switch is in the TRIGGER INTERLOCK position.</li> <li>2. Verify operation of the gun trigger.</li> </ol>	
No shielding gas	<ol style="list-style-type: none"> <li>1. Verify the gas supply is turned on and not empty.</li> <li>2. Check the gas hose for cuts. Make sure it is not crushed.</li> <li>3. Verify the shielding gas hose is connected to the gun bushing or welding gun.</li> </ol>	

 **CAUTION**

If for any reason you do not understand the test procedures or are unable to perform the tests/repairs safely, contact your **Local Lincoln Authorized Field Service Facility** for technical troubleshooting assistance before you proceed.

Observe all Safety Guidelines detailed throughout this manual

PROBLEMS (SYMPTOMS)	POSSIBLE AREAS OF MISADJUSTMENTS(S)	RECOMMENDED COURSE OF ACTION
Variable or "hunting" arc.	<ol style="list-style-type: none"> <li>1. Check for proper size contact. Make sure the contact tip is not worn, free of spatter and not melted.</li> <li>2. Clean and tighten all electrode and work connections.</li> <li>3. Verify the proper polarity is being used for the weld procedure.</li> <li>4. Make sure the proper electrode stick-out is being maintained.</li> <li>5. Check the gas flow rate and mixture.</li> <li>6. Verify the gun bushing is tightly to the wire drive.</li> <li>7. Verify the gun is tightly mounted to the gun bushing.</li> </ol>	<p>If all recommended possible areas of misadjustment have been checked and the problem persists, <b>Contact your local Lincoln Authorized Field Service Facility.</b></p>
The motor thermal LED illuminates.	<ol style="list-style-type: none"> <li>1. Check for sharp bends in the gun liner.</li> <li>2. Examine the contact tip for wear and proper size. Replace as necessary.</li> <li>3. Check the gun liner. The welding electrode should slide easily through the gun.</li> <li>4. Verify the proper gun liner is installed.</li> <li>5. Reduce the pressure arm setting.</li> <li>6. On bench models, make sure the brake tension is not too tight.</li> <li>7. If using a wire conduit, verify the wire slides easily through the conduit.</li> </ol>	
When the gun trigger is pulled, the drive rolls spin but no arc is present.	<ol style="list-style-type: none"> <li>1. Check all electrode and work connections.</li> <li>2. Verify the gun bushing is tightly to the wire drive.</li> <li>3. Verify the gun is tightly mounted to the gun bushing.</li> <li>4. Check the control cable and connectors for cuts. Verify that no pins are broken or bent.</li> </ol>	
The arc burns back to the tip at the end of the weld.	<ol style="list-style-type: none"> <li>1. If the timer kit is installed, reduce the amount of burnback time.</li> </ol>	
The gas continues to flow for a long time at the end of a weld.	<ol style="list-style-type: none"> <li>1. If the timer kit is installed, reduce the amount of postflow time.</li> </ol>	

 **CAUTION**

If for any reason you do not understand the test procedures or are unable to perform the tests/repairs safely, contact your **Local Lincoln Authorized Field Service Facility** for technical troubleshooting assistance before you proceed.



LF-72 FEEDER (11075, 11076, 11077)

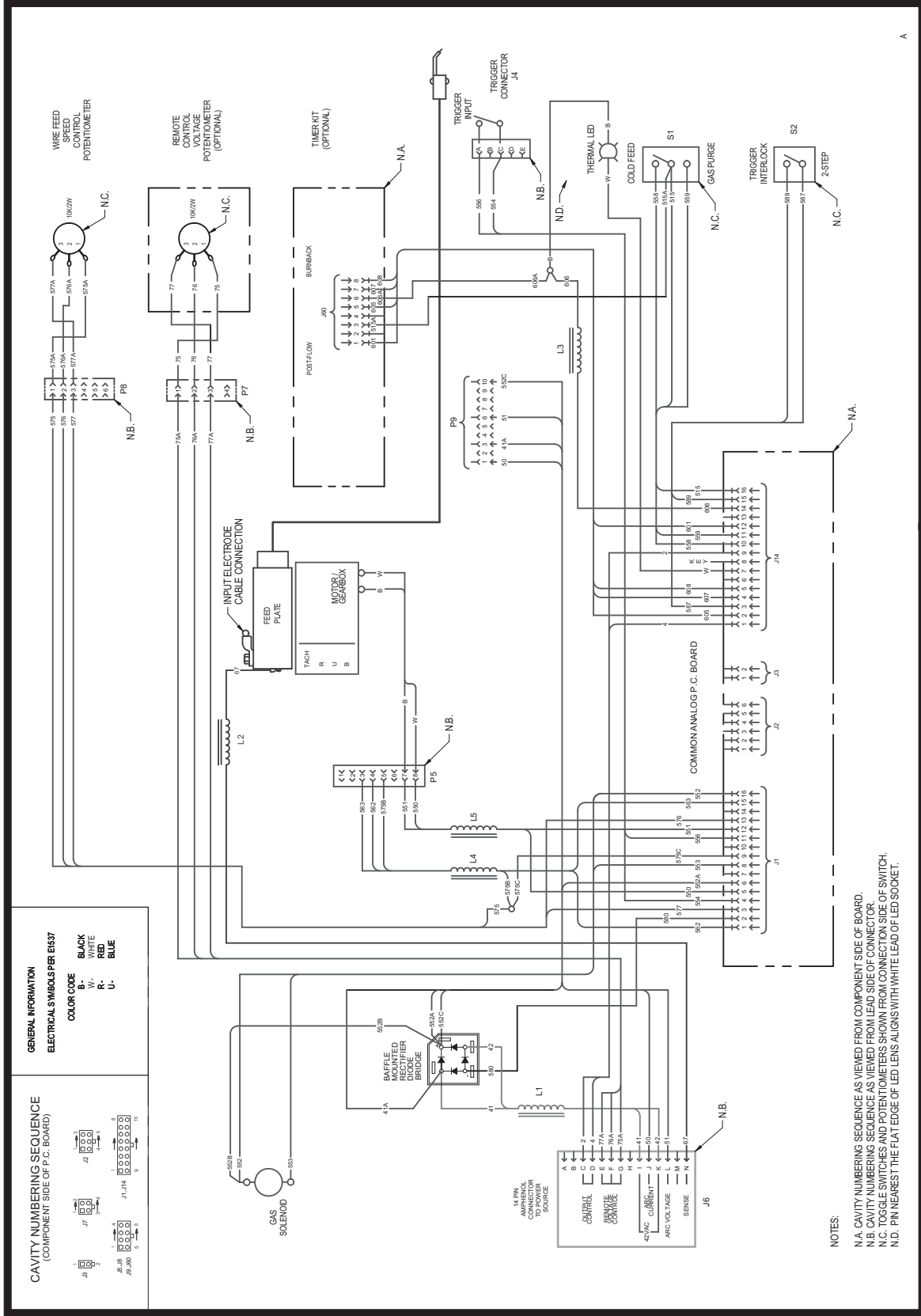

L12146

NOTE: This diagram is for reference only. It may not be accurate for all machines covered by this manual. The specific diagram for a particular code is pasted inside the machine on one of the enclosure panels. If the diagram is illegible, write to the Service Department for a replacement. Give the equipment code number.

NOTES:  
N.A. CAVITY NUMBERING SEQUENCE AS VIEWED FROM COMPONENT SIDE OF BOARD.  
N.B. CAVITY NUMBERING SEQUENCE AS VIEWED FROM LEAD SIDE OF CONNECTOR.  
N.C. TOGGLE SWITCHES AND POTENTIOMETERS SHOWN FROM CONNECTION SIDE OF SWITCH.  
N.D. PIN NEAREST THE FLAT EDGE OF LED LENS ALIGNS WITH WHITE LEAD OF LED SOCKET.

LF-72 FEEDER (FOR CODES 11209, 11210, 11211 11227)

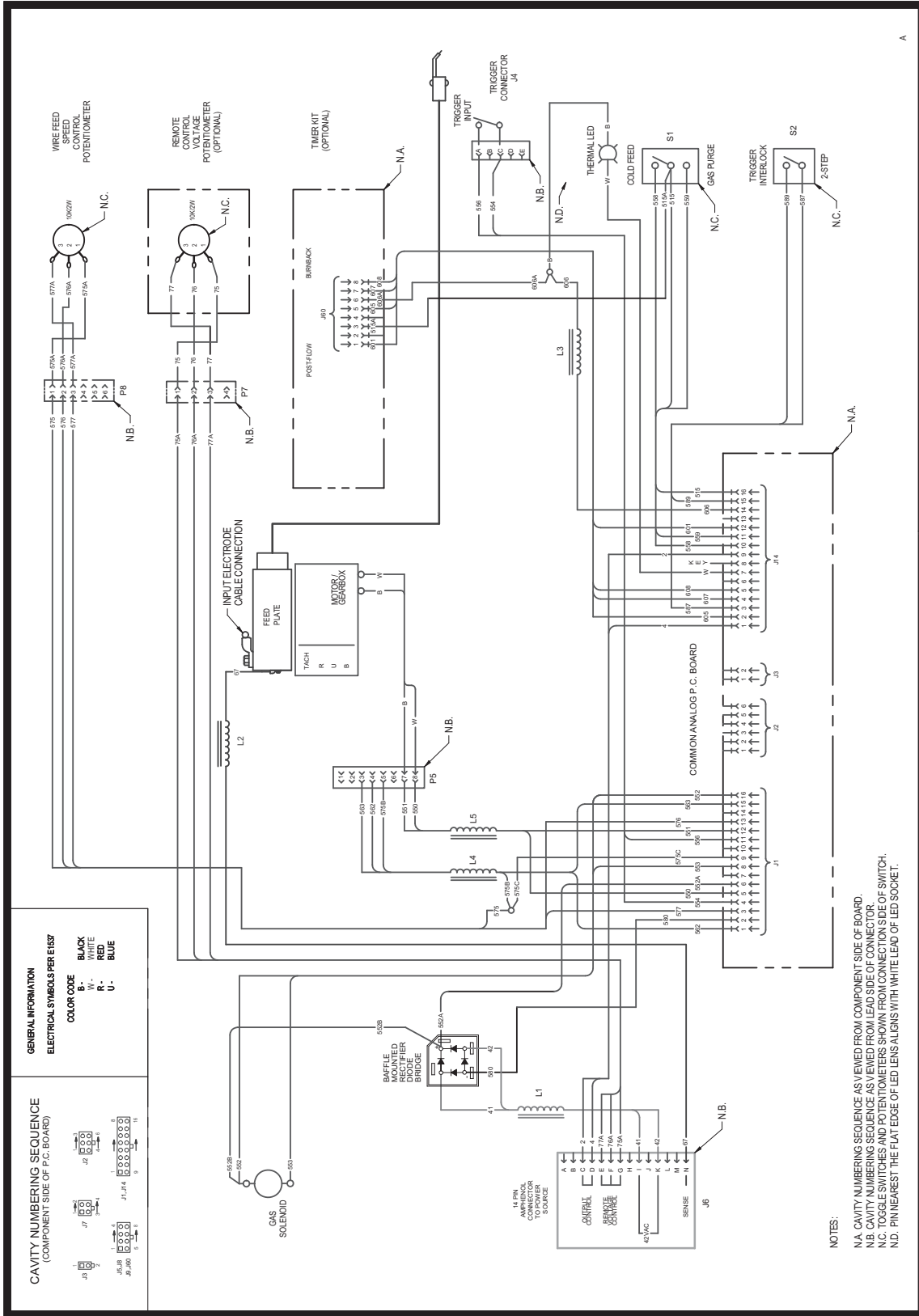

L12146-1

NOTE: This diagram is for reference only. It may not be accurate for all machines covered by this manual. The specific diagram for a particular code is pasted inside the machine on one of the enclosure panels. If the diagram is illegible, write to the Service Department for a replacement. Give the equipment code number.

# LF-72 FEEDER (FOR CODES 11290, 11291, 11292 11293)

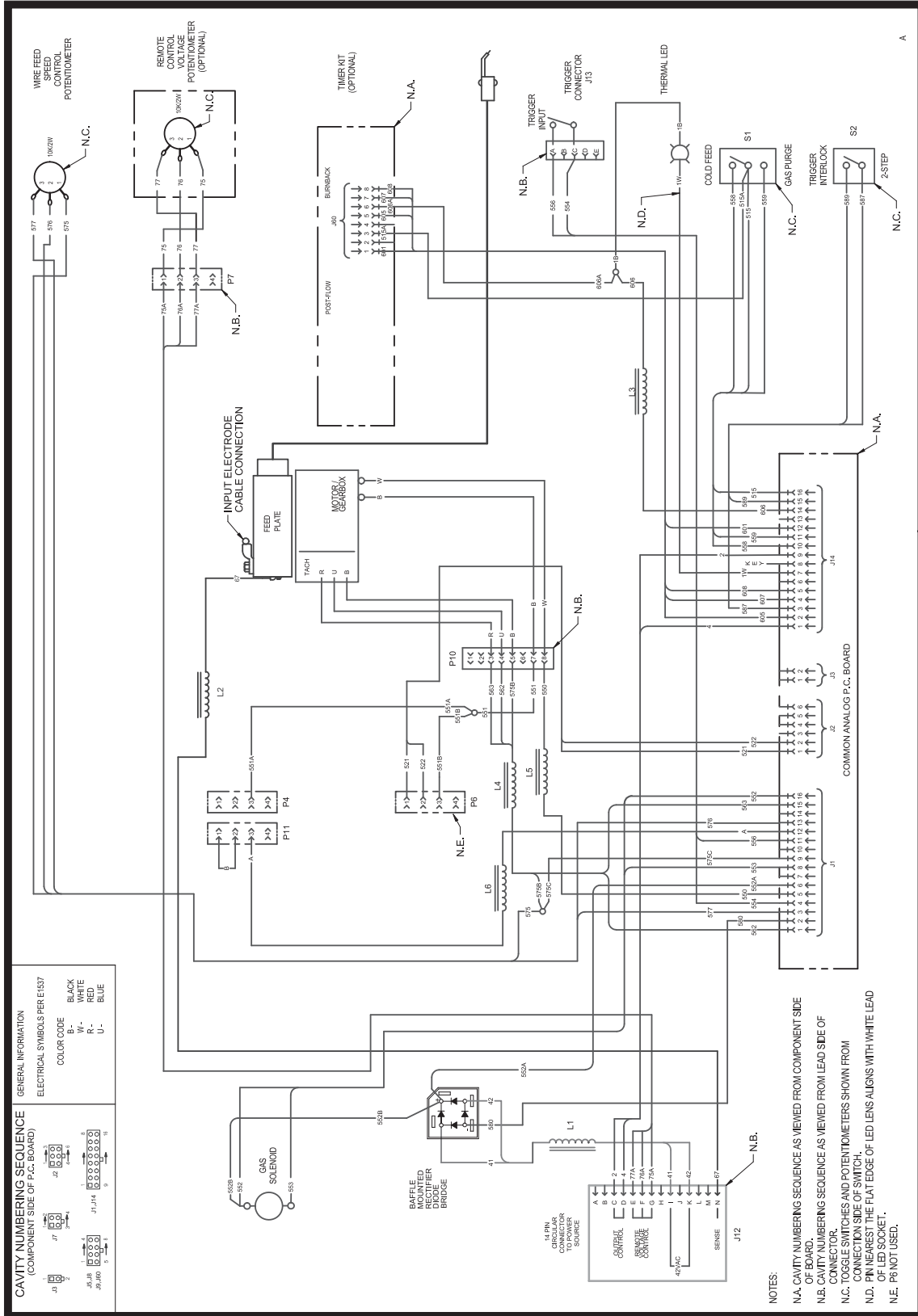

L12146-2

NOTE: This diagram is for reference only. It may not be accurate for all machines covered by this manual. The specific diagram for a particular code is pasted inside the machine on one of the enclosure panels. If the diagram is illegible, write to the Service Department for a replacement. Give the equipment code number.

WIRING DIAGRAM FOR LF-72 FEEDER (CODES 11606, 11607, 11608, 11609, 11708, 11709, 11710, 11711)

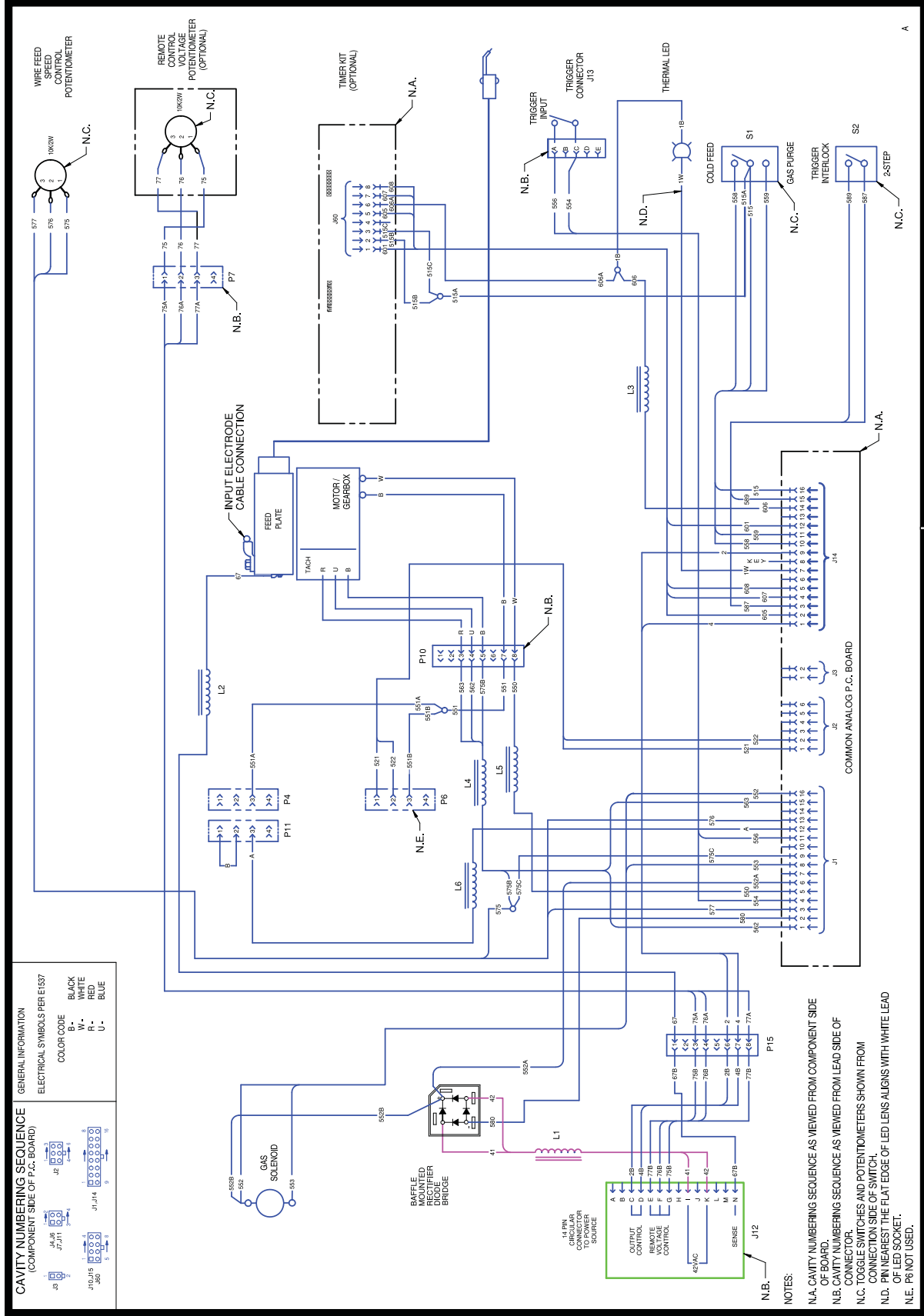

**L12146-3**

**NOTE:** This diagram is for reference only. It may not be accurate for all machines covered by this manual. The specific diagram for a particular code is pasted inside the machine on one of the enclosure panels. If the diagram is illegible, write to the Service Department for a replacement. Give the equipment code number.

BENCH MODEL

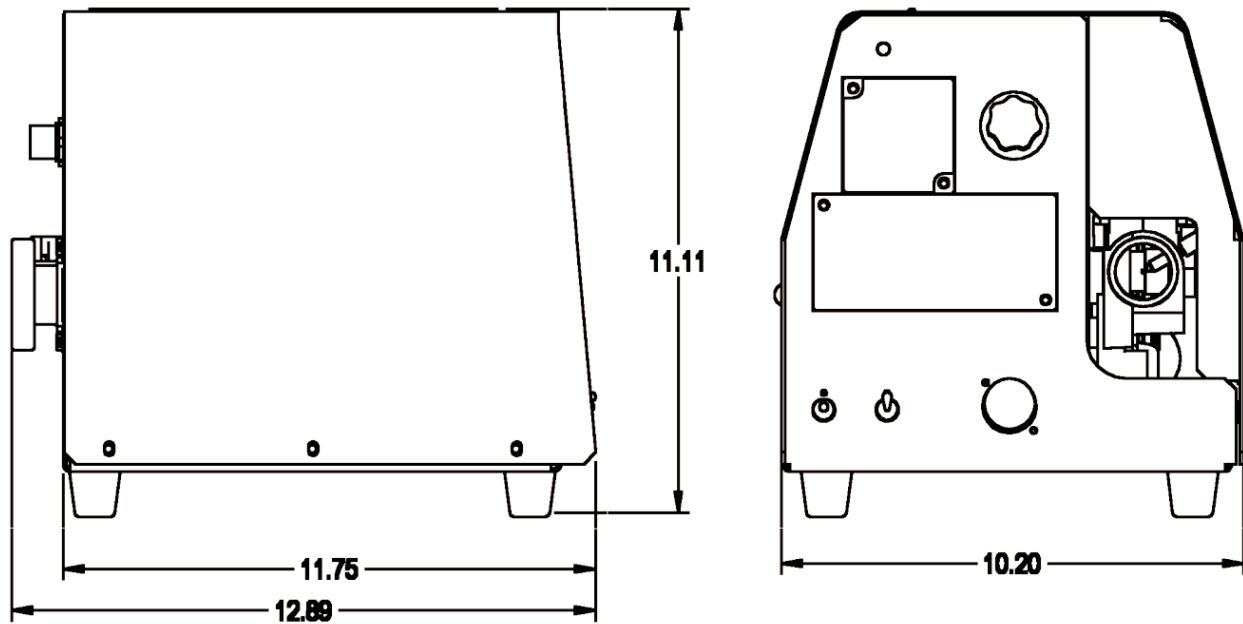

BENCH MODEL STANDARD DUTY

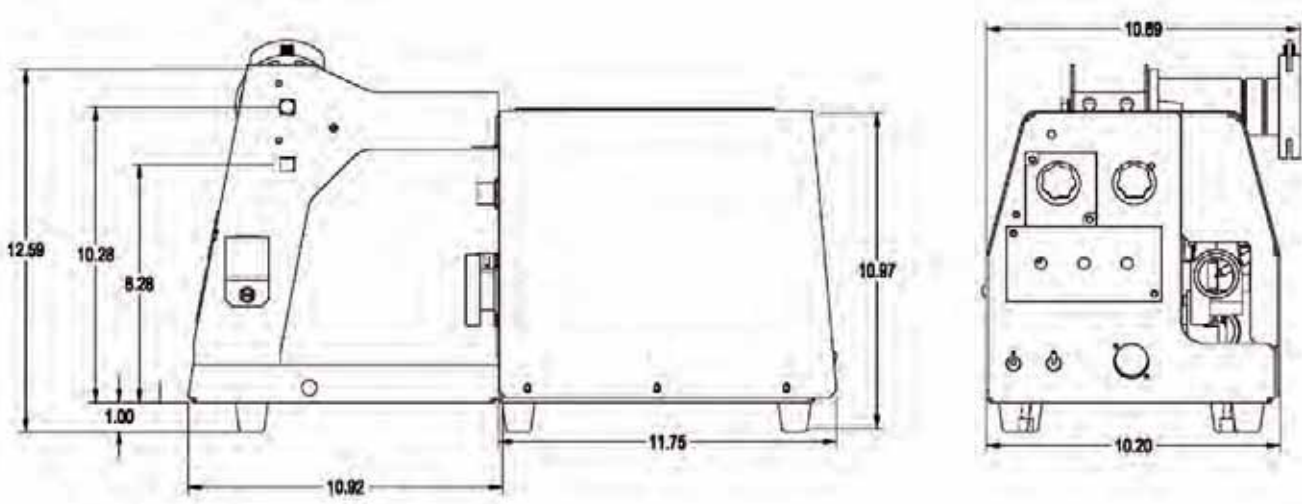

BENCH MODEL HEAVY DUTY

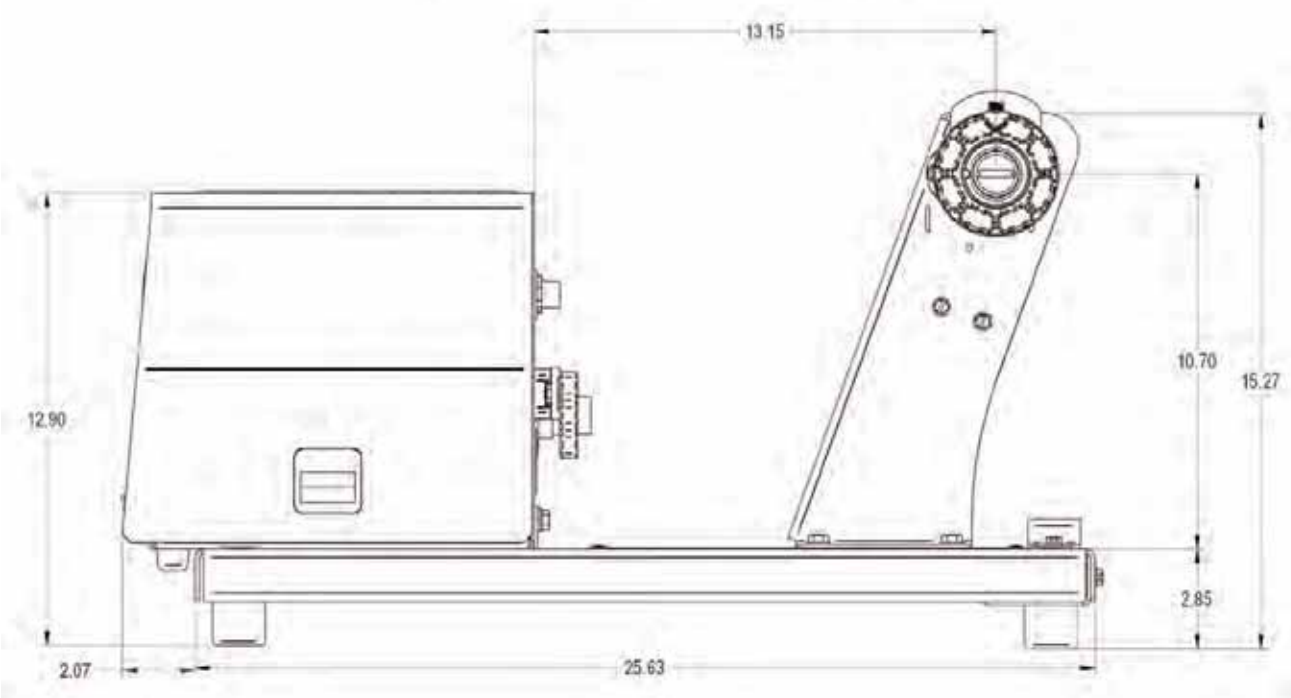
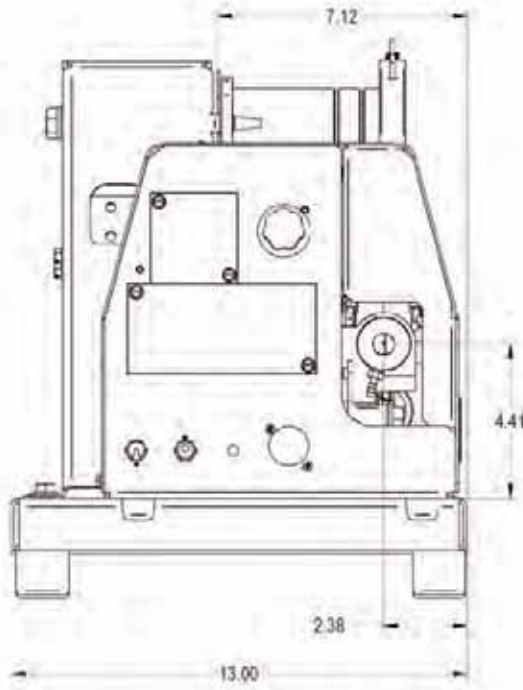

<b>WARNING</b>	<ul style="list-style-type: none"> <li>● Do not touch electrically live parts or electrode with skin or wet clothing.</li> <li>● Insulate yourself from work and ground.</li> </ul>	<ul style="list-style-type: none"> <li>● Keep flammable materials away.</li> </ul>	<ul style="list-style-type: none"> <li>● Wear eye, ear and body protection.</li> </ul>
Spanish <b>AVISO DE PRECAUCION</b>	<ul style="list-style-type: none"> <li>● No toque las partes o los electrodos bajo carga con la piel o ropa mojada.</li> <li>● Aíslese del trabajo y de la tierra.</li> </ul>	<ul style="list-style-type: none"> <li>● Mantenga el material combustible fuera del área de trabajo.</li> </ul>	<ul style="list-style-type: none"> <li>● Protéjase los ojos, los oídos y el cuerpo.</li> </ul>
French <b>ATTENTION</b>	<ul style="list-style-type: none"> <li>● Ne laissez ni la peau ni des vêtements mouillés entrer en contact avec des pièces sous tension.</li> <li>● Isolez-vous du travail et de la terre.</li> </ul>	<ul style="list-style-type: none"> <li>● Gardez à l'écart de tout matériel inflammable.</li> </ul>	<ul style="list-style-type: none"> <li>● Protégez vos yeux, vos oreilles et votre corps.</li> </ul>
German <b>WARNUNG</b>	<ul style="list-style-type: none"> <li>● Berühren Sie keine stromführenden Teile oder Elektroden mit Ihrem Körper oder feuchter Kleidung!</li> <li>● Isolieren Sie sich von den Elektroden und dem Erdboden!</li> </ul>	<ul style="list-style-type: none"> <li>● Entfernen Sie brennbares Material!</li> </ul>	<ul style="list-style-type: none"> <li>● Tragen Sie Augen-, Ohren- und Körperschutz!</li> </ul>
Portuguese <b>ATENÇÃO</b>	<ul style="list-style-type: none"> <li>● Não toque partes elétricas e electrodos com a pele ou roupa molhada.</li> <li>● Isole-se da peça e terra.</li> </ul>	<ul style="list-style-type: none"> <li>● Mantenha inflamáveis bem guardados.</li> </ul>	<ul style="list-style-type: none"> <li>● Use proteção para a vista, ouvido e corpo.</li> </ul>
Japanese <b>注意事項</b>	<ul style="list-style-type: none"> <li>● 通電中の電気部品、又は溶材にヒブやぬれた布で触れないこと。</li> <li>● 施工物やアースから身体が絶縁されている様にして下さい。</li> </ul>	<ul style="list-style-type: none"> <li>● 燃えやすいものの側での溶接作業は絶対にしてはなりません。</li> </ul>	<ul style="list-style-type: none"> <li>● 目、耳及び身体に保護具をして下さい。</li> </ul>
Chinese <b>警告</b>	<ul style="list-style-type: none"> <li>● 皮肤或湿衣物切勿接触带电部件及焊条。</li> <li>● 使你自己与地面和工作件绝缘。</li> </ul>	<ul style="list-style-type: none"> <li>● 把一切易燃物品移离工作场所。</li> </ul>	<ul style="list-style-type: none"> <li>● 佩戴眼、耳及身体劳动保护用具。</li> </ul>
Korean <b>위험</b>	<ul style="list-style-type: none"> <li>● 전도체나 용접봉을 젖은 청킹 또는 피부로 절대 접촉치 마십시오.</li> <li>● 모재와 접지를 접촉치 마십시오.</li> </ul>	<ul style="list-style-type: none"> <li>● 인화성 물질을 접근시키지 마십시오.</li> </ul>	<ul style="list-style-type: none"> <li>● 눈, 귀와 몸에 보호장구를 착용하십시오.</li> </ul>
Arabic <b>تحذير</b>	<ul style="list-style-type: none"> <li>● لا تلمس الاجزاء التي يسري فيها التيار الكهربائي أو الألكترود بجك الجسم أو بالملابس المبللة بالماء.</li> <li>● ضع عازلا على جسمك خلال العمل.</li> </ul>	<ul style="list-style-type: none"> <li>● ضع المواد القابلة للاشتعال في مكان بعيد.</li> </ul>	<ul style="list-style-type: none"> <li>● ضع أدوات وملابس واقية على عينيك وأذنيك وجسمك.</li> </ul>

**READ AND UNDERSTAND THE MANUFACTURER'S INSTRUCTION FOR THIS EQUIPMENT AND THE CONSUMABLES TO BE USED AND FOLLOW YOUR EMPLOYER'S SAFETY PRACTICES.**

**SE RECOMIENDA LEER Y ENTENDER LAS INSTRUCCIONES DEL FABRICANTE PARA EL USO DE ESTE EQUIPO Y LOS CONSUMIBLES QUE VA A UTILIZAR, SIGA LAS MEDIDAS DE SEGURIDAD DE SU SUPERVISOR.**

**LISEZ ET COMPRENEZ LES INSTRUCTIONS DU FABRICANT EN CE QUI REGARDE CET EQUIPMENT ET LES PRODUITS A ETRE EMPLOYES ET SUIVEZ LES PROCEDURES DE SECURITE DE VOTRE EMPLOYEUR.**

**LESEN SIE UND BEFOLGEN SIE DIE BETRIEBSANLEITUNG DER ANLAGE UND DEN ELEKTRODENEINSATZ DES HERSTELLERS. DIE UNFALLVERHÜTUNGSVORSCHRIFTEN DES ARBEITGEBERS SIND EBENFALLS ZU BEACHTEN.**

			
<ul style="list-style-type: none"> <li>● Keep your head out of fumes.</li> <li>● Use ventilation or exhaust to remove fumes from breathing zone.</li> </ul>	<ul style="list-style-type: none"> <li>● Turn power off before servicing.</li> </ul>	<ul style="list-style-type: none"> <li>● Do not operate with panel open or guards off.</li> </ul>	<b>WARNING</b>
<ul style="list-style-type: none"> <li>● Los humos fuera de la zona de respiración.</li> <li>● Mantenga la cabeza fuera de los humos. Utilice ventilación o aspiración para gases.</li> </ul>	<ul style="list-style-type: none"> <li>● Desconectar el cable de alimentación de poder de la máquina antes de iniciar cualquier servicio.</li> </ul>	<ul style="list-style-type: none"> <li>● No operar con panel abierto o guardas quitadas.</li> </ul>	Spanish <b>AVISO DE PRECAUCION</b>
<ul style="list-style-type: none"> <li>● Gardez la tête à l'écart des fumées.</li> <li>● Utilisez un ventilateur ou un aspirateur pour ôter les fumées des zones de travail.</li> </ul>	<ul style="list-style-type: none"> <li>● Débranchez le courant avant l'entretien.</li> </ul>	<ul style="list-style-type: none"> <li>● N'opérez pas avec les panneaux ouverts ou avec les dispositifs de protection enlevés.</li> </ul>	French <b>ATTENTION</b>
<ul style="list-style-type: none"> <li>● Vermeiden Sie das Einatmen von Schweißrauch!</li> <li>● Sorgen Sie für gute Be- und Entlüftung des Arbeitsplatzes!</li> </ul>	<ul style="list-style-type: none"> <li>● Strom vor Wartungsarbeiten abschalten! (Netzstrom völlig öffnen; Maschine anhalten!)</li> </ul>	<ul style="list-style-type: none"> <li>● Anlage nie ohne Schutzgehäuse oder Innenschutzverkleidung in Betrieb setzen!</li> </ul>	German <b>WARNUNG</b>
<ul style="list-style-type: none"> <li>● Mantenha seu rosto da fumaça.</li> <li>● Use ventilação e exaustão para remover fumo da zona respiratória.</li> </ul>	<ul style="list-style-type: none"> <li>● Não opere com as tampas removidas.</li> <li>● Desligue a corrente antes de fazer serviço.</li> <li>● Não toque as partes elétricas nuas.</li> </ul>	<ul style="list-style-type: none"> <li>● Mantenha-se afastado das partes moventes.</li> <li>● Não opere com os painéis abertos ou guardas removidas.</li> </ul>	Portuguese <b>ATENÇÃO</b>
<ul style="list-style-type: none"> <li>● ヒュームから頭を離すようにして下さい。</li> <li>● 換気や排煙に十分留意して下さい。</li> </ul>	<ul style="list-style-type: none"> <li>● メンテナンス・サービスに取りかかる際には、まず電源スイッチを必ず切ってください。</li> </ul>	<ul style="list-style-type: none"> <li>● パネルやカバーを取り外したまま機械操作をしないで下さい。</li> </ul>	Japanese <b>注意事項</b>
<ul style="list-style-type: none"> <li>● 頭部遠離煙霧。</li> <li>● 在呼吸區使用通風或排風器除煙。</li> </ul>	<ul style="list-style-type: none"> <li>● 維修前切斷電源。</li> </ul>	<ul style="list-style-type: none"> <li>● 儀表板打開或沒有安全罩時不準作業。</li> </ul>	Chinese <b>警告</b>
<ul style="list-style-type: none"> <li>● 얼굴로부터 용접가스를 멀리하십시오.</li> <li>● 호흡지역으로부터 용접가스를 제거하기 위해 가스제거기나 통풍기를 사용하십시오.</li> </ul>	<ul style="list-style-type: none"> <li>● 보수전에 전원을 차단하십시오.</li> </ul>	<ul style="list-style-type: none"> <li>● 관널이 열린 상태로 작동치 마십시오.</li> </ul>	Korean <b>위험</b>
<ul style="list-style-type: none"> <li>● ابعد رأسك بعيداً عن الدخان.</li> <li>● استعمل التهوية أو جهاز ضغط الدخان للخارج لكي تبعد الدخان عن المنطقة التي تتنفس فيها.</li> </ul>	<ul style="list-style-type: none"> <li>● اقطع التيار الكهربائي قبل القيام بأية صيانة.</li> </ul>	<ul style="list-style-type: none"> <li>● لا تشغيل هذا الجهاز اذا كانت الاغطية الحديدية الواقية ليست عليه.</li> </ul>	Arabic <b>تحذير</b>

**LEIA E COMPREENDA AS INSTRUÇÕES DO FABRICANTE PARA ESTE EQUIPAMENTO E AS PARTES DE USO, E SIGA AS PRÁTICAS DE SEGURANÇA DO EMPREGADOR.**

使う機械や溶材のメーカーの指示書をよく読み、まず理解して下さい。そして貴社の安全規定に従って下さい。

請詳細閱讀並理解製造廠提供的說明以及應該使用的銀焊材料，並請遵守貴方的有閣勞動保護規定。

이 제품에 동봉된 작업지침서를 숙지하시고 귀사의 작업자 안전수칙을 준수하시기 바랍니다.

اقرأ بتمعن وافهم تعليمات المصنع المنتج لهذه المعدات والمواد قبل استعمالها واتبع تعليمات الوقاية لصاحب العمل.





• World's Leader in Welding and Cutting Products •

• Sales and Service through Subsidiaries and Distributors Worldwide •

Cleveland, Ohio 44117-1199 U.S.A. TEL: 216.481.8100 FAX: 216.486.1751 WEB SITE: [www.lincolnelectric.com](http://www.lincolnelectric.com)