

T40 Oil Level

Normally the model T40 transaxle, that is featured in many tractor & rider models, does not require any servicing for the life of the vehicle. However, if there is a desire to check or add oil, it may be necessary to remove the transaxle from the vehicle in order to access the black cap located under the pulley & fan (on drive shaft).

After placing the transaxle on a level surface remove the fan & pulley and pry open the black cap (shown in Fig. #1 below). Oil level should be maintained at 20~25 mm (3/4"~1") below the lip of (black cap) port, when oil temperature is at room temperature (20°C or 68° F).

While reinstalling the fan & pulley on drive shaft be sure to place all components in the same order as they were removed.

Alternative checking location is through the breather port as shown in Figure #2 (next page). Oil level at this location should be maintained at 37~42 mm (1 7/16"~1 5/8") below lip of breather port. At this check point care should be taken not to damage breather cap during its removal.

Figure #1

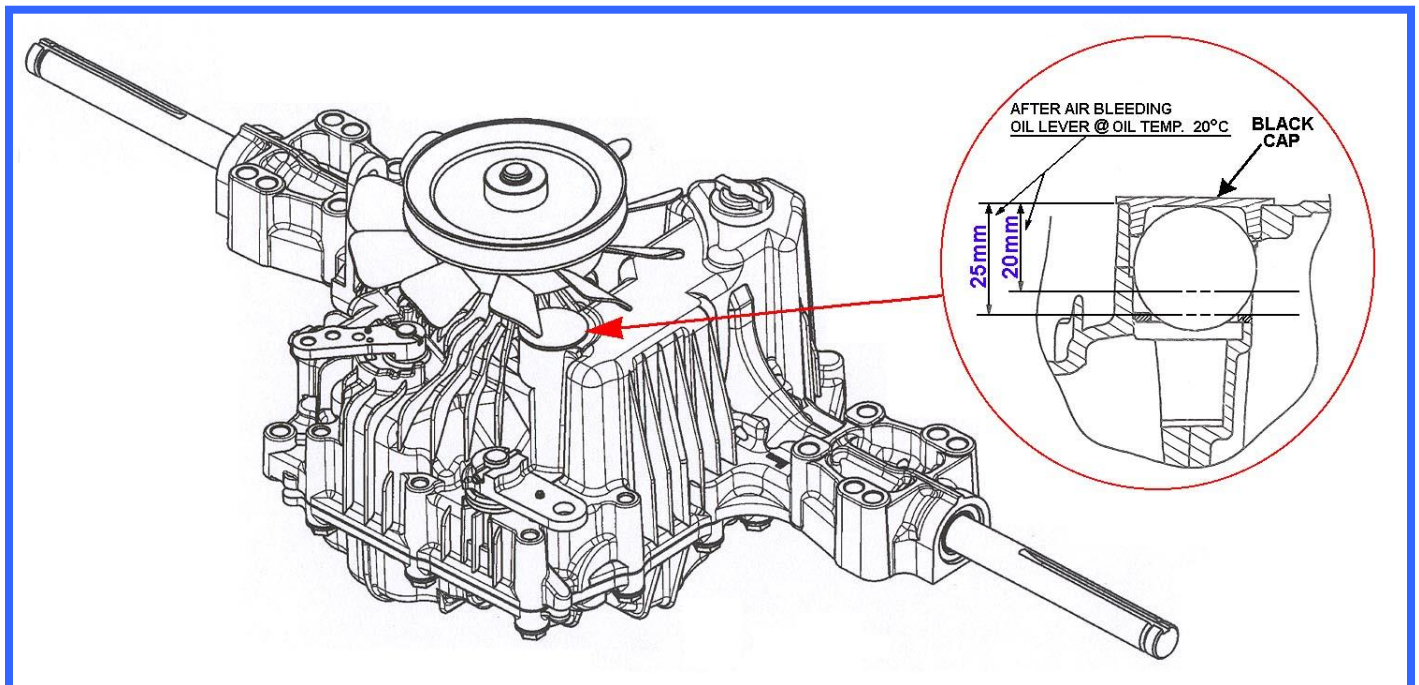

Figure #2

