



Tuff Torq K46/T40 TRANSAXLE Resealing process

Presented by TTC

Time required: 30 minutes

Note: Some models may vary in appearance. This diagram is intended to document the resealing process only.



Tools Needed

- Sealant scraper
- Screw driver
- Torque wrench
- 12 mm socket
- Ratchet or impact gun
- Rubber mallet
- Sealant

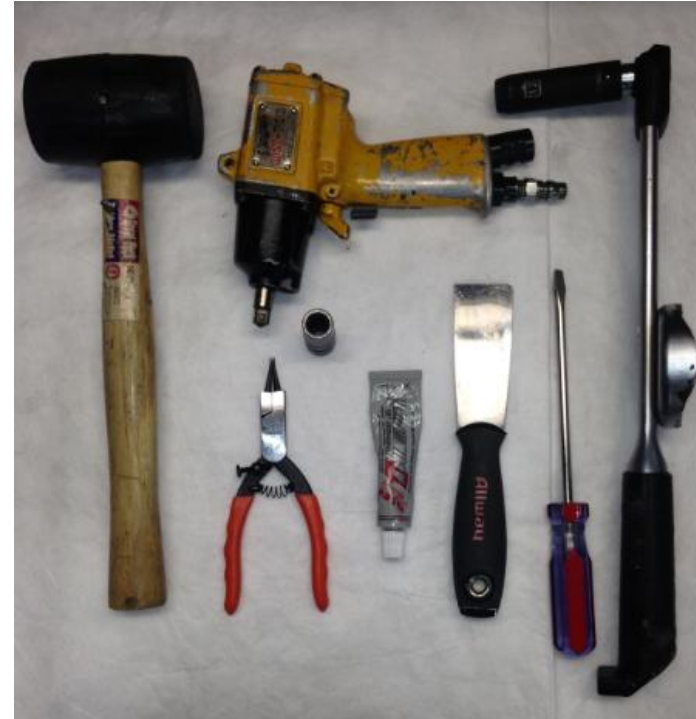

Work Area: All work must be performed in a clean and well-lit area to prevent contaminations from entering the hydro mechanical drive system.



 Remove the snap ring, fan, and pulley

 Discard the old snap ring



 Remove the sealing cap by prying up with a flat screw driver. Also remove the magnet.

Note: Be careful to not damage the sealing surface





 Drain the fluid

 Remove 12 mm bolts

 Use a screw driver to separate housings at pressure tabs.

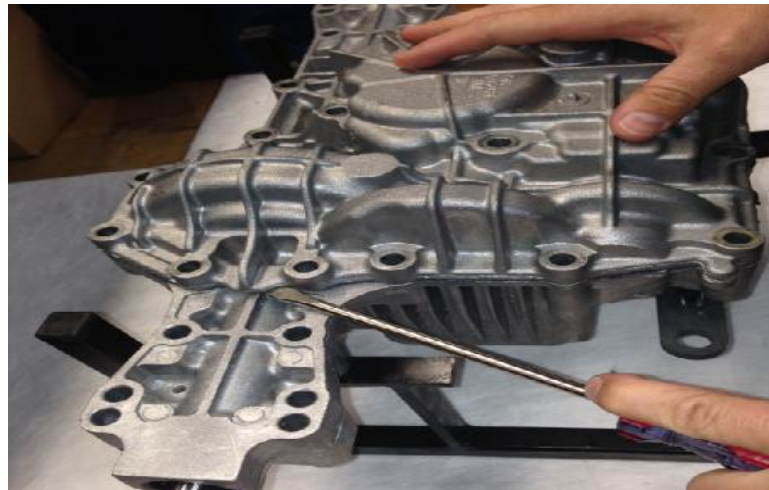
Note: Use caution to protect the sealing surface of the housings.



 Scrape all sealant from the upper and lower case halves

 Wipe case halves with a clean rag so that all residual oil and sealant is removed.

 Apply 1/8" bead of John Deere approved sealant to the lower housing

Note: Sealant is to be applied around the lower case with the bead to the inside of the bolt holes. It should also be applied around the internal bolt holes.

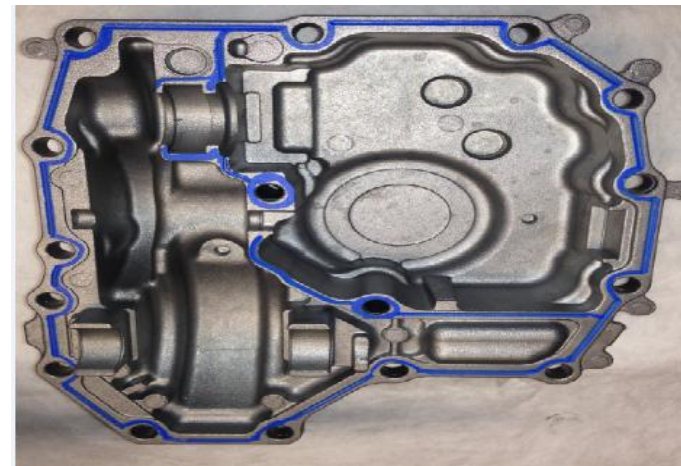

 Reassemble upper and lower cases together



 Install center bolts first and then install bolts around the perimeter in a cross over pattern

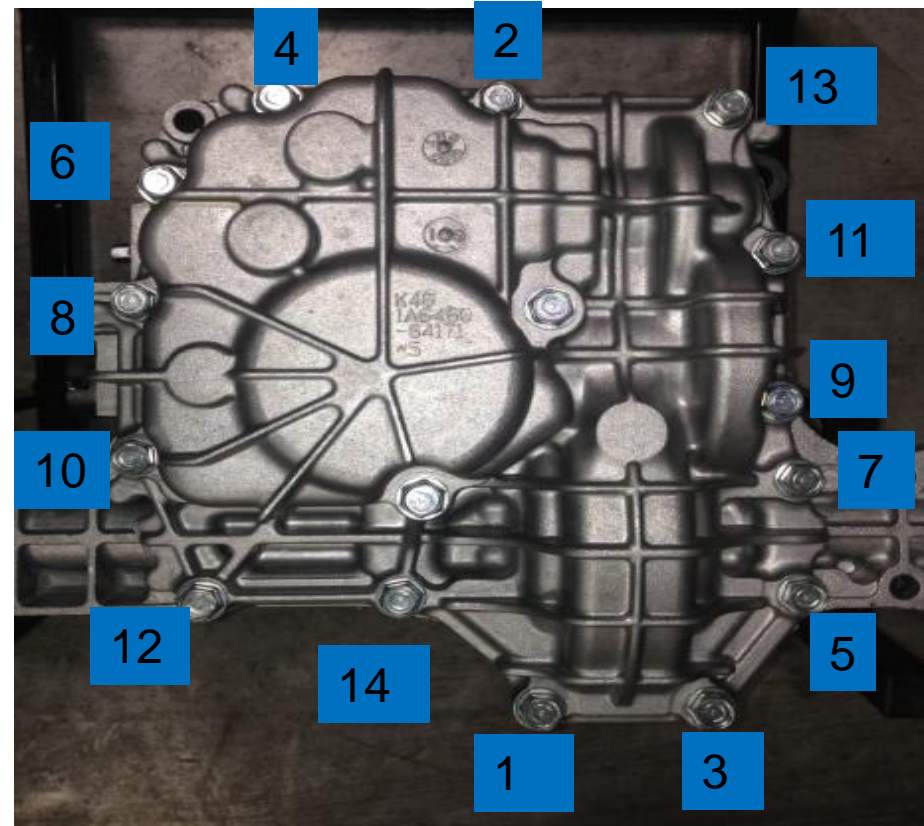

- ⚙️ Torque all case bolts at 22.5-27.4 Nm (2.29-2.79 kgf-m)
- ⚙️ Wait 1 hour and refill with oil
- ⚙️ See oil level height below Oil level should be maintained at 20~25 mm (3/4"~1") below the lip of (black cap) port.

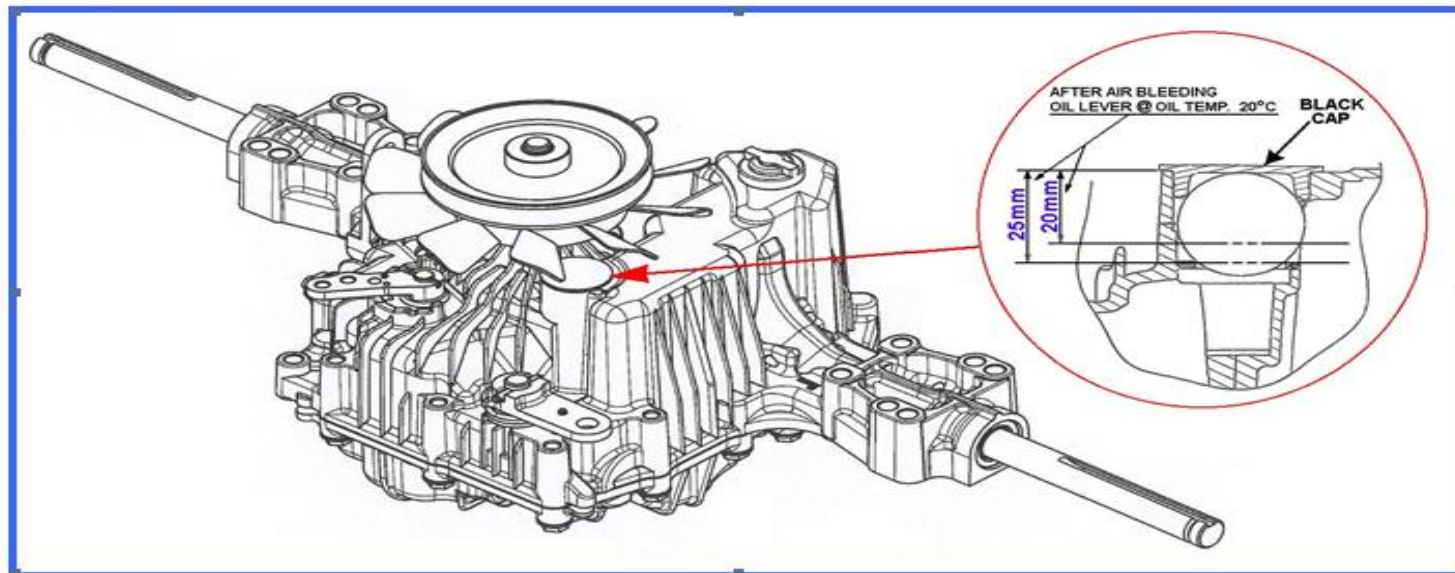

 Reinstall magnet, sealing cap, fan, pulley, and snap ring.



TUFF TORQ®

5943 Commerce Boulevard

Morristown, TN 37814

423.585.2000

www.tufftorq.com

