

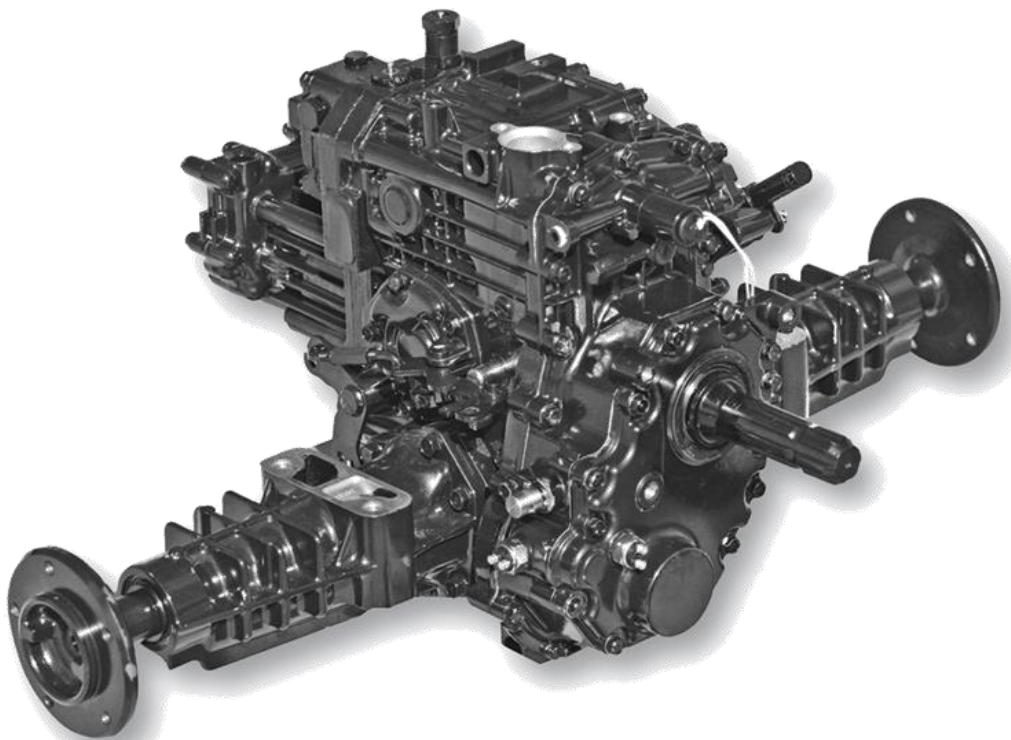

SERVICE MANUAL
K92



HYDROSTATIC TRANSAXLE

DRIVING YOUR BEST IDEAS

Table of Contents

4WD Output Disassembly and Assembly	24
Brakes Removal and Installation	43
Center Valve Block Disassembly and Assembly	33
Charge Pump Disassembly and Assembly	2
Charge Pump Removal and Installation	2
Control Arm and Damper Removal and Installation.....	1
Differential (2WD) Disassembly and Assembly	20
Differential (4WD) Disassembly and Assembly	21
Differential Lock Shaft Disassembly and Assembly	19
General Specifications.....	iv
Hydrostatic Flow Diagram Check Points	44
Hydrostatic Pump Inspection.....	35
Hydrostatic Transmission 2WD and 4WD	28
Hydrostatic Transmission Installation.....	35
Hydrostatic Transmission Motor Disassembly and Assembly (2WD)	29
Hydrostatic Transmission Motor Disassembly and Assembly (4WD)	31
Hydrostatic Transmission Motor Installation	34
Inspection of Transaxle Case	39
K92 Transmission Component Location.....	vi
Ordering Replacement Parts Online	ii
PTO Brake Removal and Installation	6
PTO Clutch Disassembly, Inspection and Assembly	22
PTO Drive Train (Mid-PTO) Removal and Installation	9
PTO Drive Train (Mid and Rear PTO) Removal and Installation	11
PTO Relief Valve Disassembly, Inspection and Assembly	6
PTO Relief Valve Removal and Installation	6
PTO Solenoid Valve.....	4
Rear Axle Assembly - Disassembly and Assembly.....	42
Rear Axle Assembly Removal and Installation	41
Rear PTO Assembly	17
Rear PTO Removal and Installation	14
Recommended Tools and Equipment.....	iv
Serial Number Location.....	iv
Transaxle (Right Cover) Disassembly and Assembly.....	38
Transaxle Disassembly	36
Troubleshooting Guides	46

Ordering Replacement Parts Online

www.tufftorq.com



Home

At Tuff Torq, we offer our customers quality products at a modest price. A manufacturer of hydrostatic and gear drive transmissions for the power equipment industry, Tuff Torq offers a complete line of transmissions and parts to help fit your needs.

Designed to meet the needs of our OEM customers, this web site is designed to assist service and re-pair facilities in locating and ordering parts for Tuff Torq manufactured transmissions. It also provides transaxle parts identification, troubleshooting guides, online ordering capabilities, as well as providing you with a complete inventory of parts, service and same day shipping.

If you are a registered user, please login (from the Welcome Page) to access the parts ordering system.

If you are not a OEM customer or authorized service distributor, you may need to contact your equipment manufacturer or authorized dealer. Select your brand (from the Welcome page) and you will be directed to the appropriate web site.

Navigating the web site:

To access Tuff Torq's web site, type in www.tufftorq.com from your Internet browser. From the Home page, click on "Service" to enter the Online Ordering page (Ref. Page 1)

From The Online Ordering page, click on "Click here to enter service web site" to enter the Welcome page (Ref. Page 2).

From the Welcome page, login (for register users) and follow the on screen instructions. Or, click on "Catalog/Order" to enter Store Browser (Ref. Page 3).

From the Catalog/Order page, select your transaxle model, e.g., K61. Click on "K61" to find the serial number for your model (Ref. Page 4).

From the Model Series page, click on, your Model to enter the Serial Number Range page (Ref. Page 5).

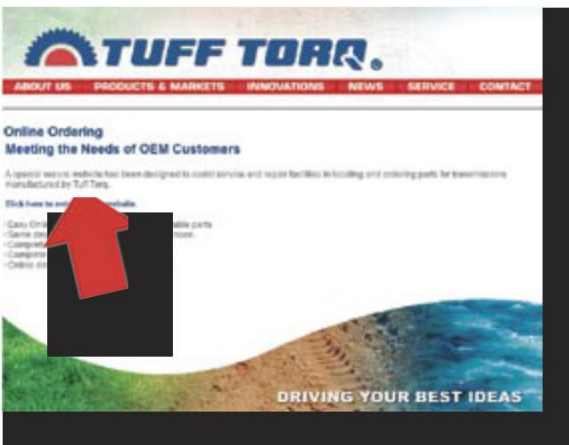

Page 1



Page 2



Page 3

Tuff Torq K92 Hydrostatic Transaxle

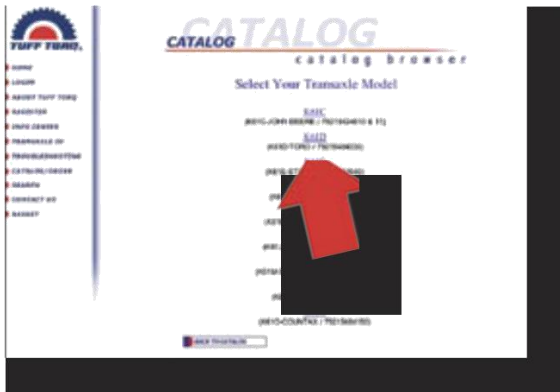

Page 4

Having your Model, and Model Series, click on the serial number to enter the Online Ordering page for you Transaxle (Ref. 6).

Navigate through the exploded parts illustration until the desired part has been identified. Take note of the part's figure number. Locate the part number in the parts listing. You can add the part to your shopping cart and return to the exploded illustration or—click on the item to go to the Product Explorer page for additional detail about the part (Ref. Page 7).

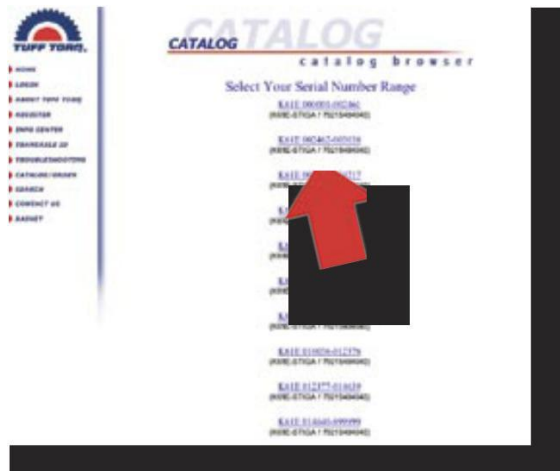

Page 5

Thank you for visiting and ordering online with Tuff Torq.

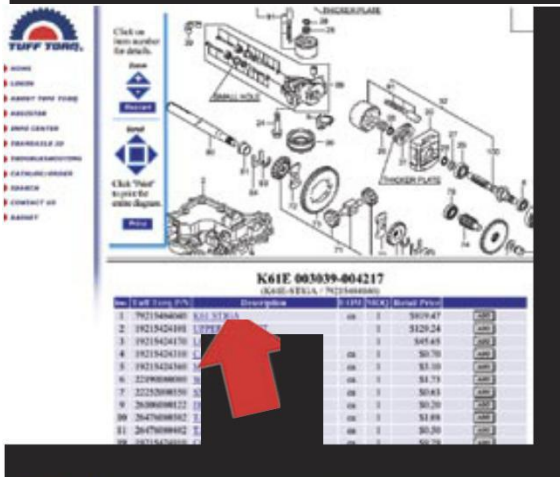

Page 6



Page 7

Recommended Tools and Equipment

1. Solenoid Valve Socket
2. Transmission Gear Spacer
3. Bushing, Bearing and Seal Driver Set
4. Press
5. Snap Ring Pliers
6. Knife-Edge Puller
7. Hoist
8. Silicon Sealant
9. Cure primer
10. Thread Lock and Sealer (Medium Strength)

Serial Number Location

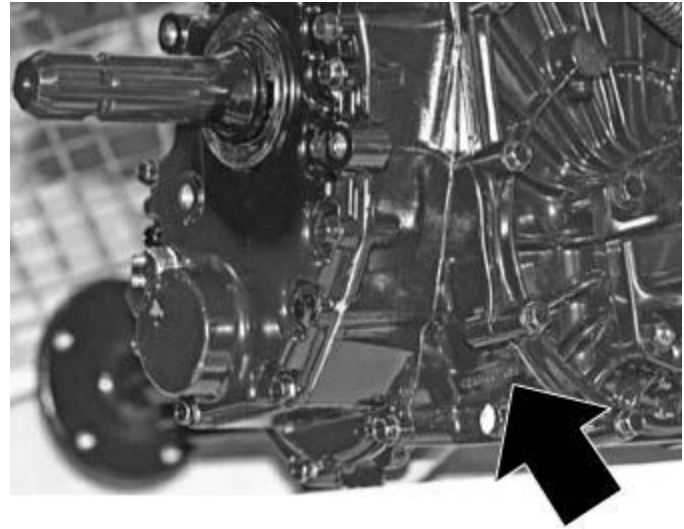

General Specifications

Transaxle:

Hydraulic Oil.....	ATF Type F
Capacity With Filter (2WD).....	7.5 L (7.9 qt)
Capacity With Filter (4WD).....	7.8 L (8.2 qt)
Capacity With Filter (4WD w/rear PTO)	9.0 L (9.5 qt)

Charge Pump:

Displacement.....	8 cc (0.49 cu.in.)/rev
Charge Pressure Control Valve (minimum).....	1950 kPa (283 psi)
Charge Pressure Relief Valve (Implement Pressure) (minimum).....	9360 kPa (135 psi)
Charge Pump Flow	22.7 L/m (6.0 gpm)
Minimum Flow	17 L/m (4.5 gpm)

PTO:

PTO Pressure Control Valve	1500 - 2000 kPa (218 - 290 psi)
PTO Circuit Flow.....	1.5 ~ 1.2 L/m (0.40 ~ 0.48 gpm)

Repair Specifications

Control Arm Cap Screw Torque.....	73 N•m (54 lb-ft)
PTO Solenoid Armature Torque.....	22 N•m (195 lb-in.)
PTO Solenoid Nut Torque.....	4.9 N•m (43 lb-in.)

General Specifications (continued)

Transaxle Cover Cap Screws:

Used Transaxle Case Torque	25 N•m (221 lb-in.)
New Transaxle Case Torque	30 N•m (22 lb-ft)
PTO Output Shaft Retaining Cap Screws Torque	27 N•m (20 lb-ft)
PTO Shifter Shaft Cap Screw Torque	25 N•m (221 lb-in.)
PTO Ball Switches Torque	34 N•m (25 lb-ft)
PTO Clutch Pack Wear Clearance Between Plate and Bottom of Gear/Hub Groove	2.7 mm (0.106 in.) maximum

Charge Pump Cap Screws:

Short Cap Screws Torque	25 N•m (221 lb-in.)
Long Cap Screw Torque	39 N•m (29 lb-ft)
Hydrostatic Motor Seal Cap Depth below Housing	4 mm (5/32 in.)
Long Cap Screw Torque	39 N•m (29 lb-ft)
Hydrostatic Motor Seal Cap Depth below Housing	4 mm (5/32 in.)

Hydrostatic Center Valve Block:

Directional Control Valves Torque	35 N•m (26 lb-ft)
Bottom Suction Plug Torque.....	50 N•m (37 lb-ft)
Charge Pressure Relief Valve Plug Torque	25 N•m (221 lb-in.)
Mounting Cap Screws Torque	39 N•m (29 lb-ft)
Axle Housing Cap Screws Torque.....	54 N•m (40 lb-ft)
King Pin Cap Screws Torque	54 N•m (40 lb-ft)
Transaxle to Frame Mounting Cap Screws and Nuts.....	71 - 106 N•m (52 - 78 lb-ft)
Differential Cap Screws Torque	88 N•m (65 lb-ft)
Drive Shaft Cap Screws Torque	40 N•m (30 lb-ft)
Hydraulic Line Fittings Torque	24 N•m (212 lb-in.)

K92 Transmission Component Location

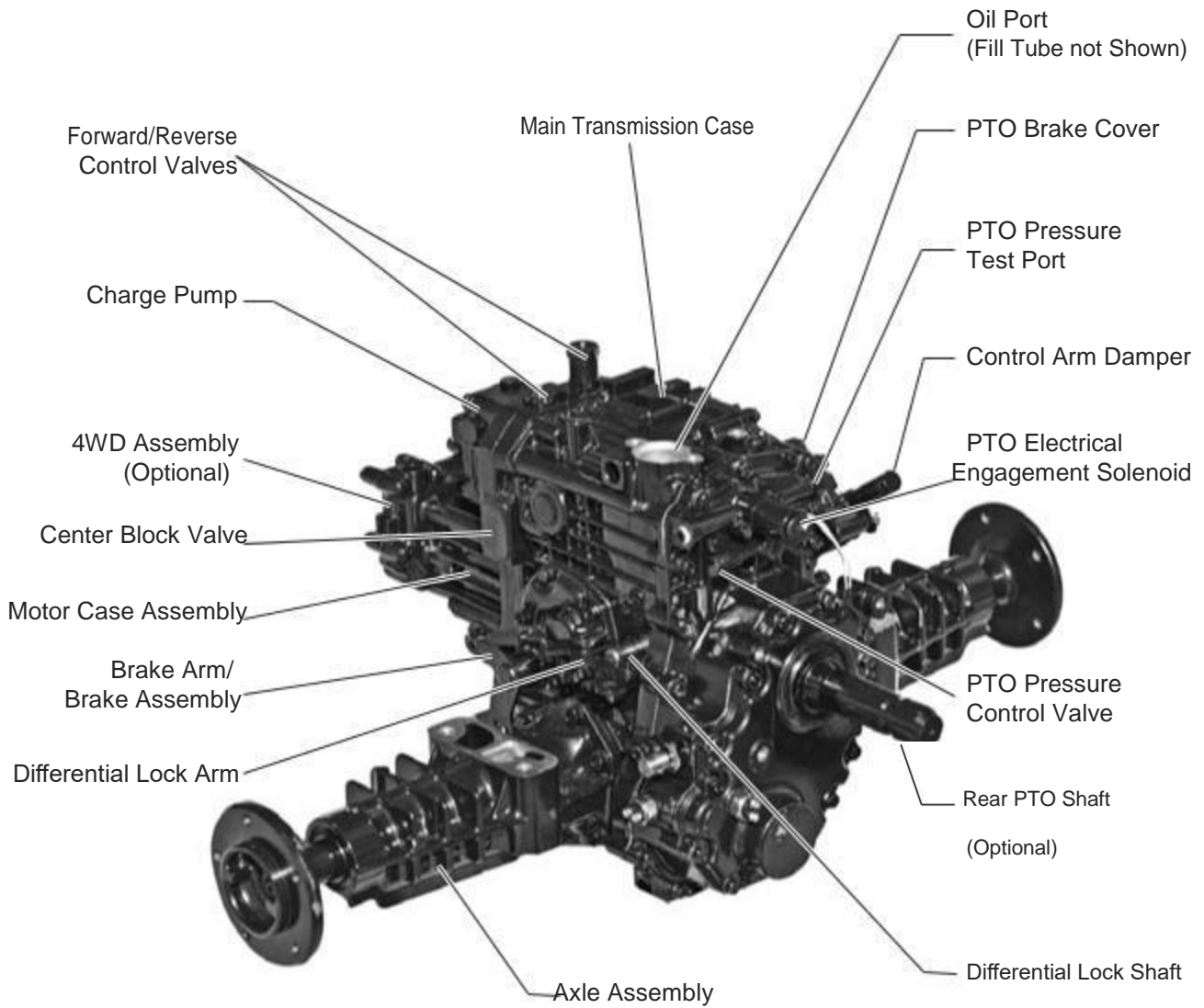

K92 Hydrostatic Transaxle

Tuff Torq K92 Hydrostatic Transaxle

Control Arm and Damper Removal and Installation

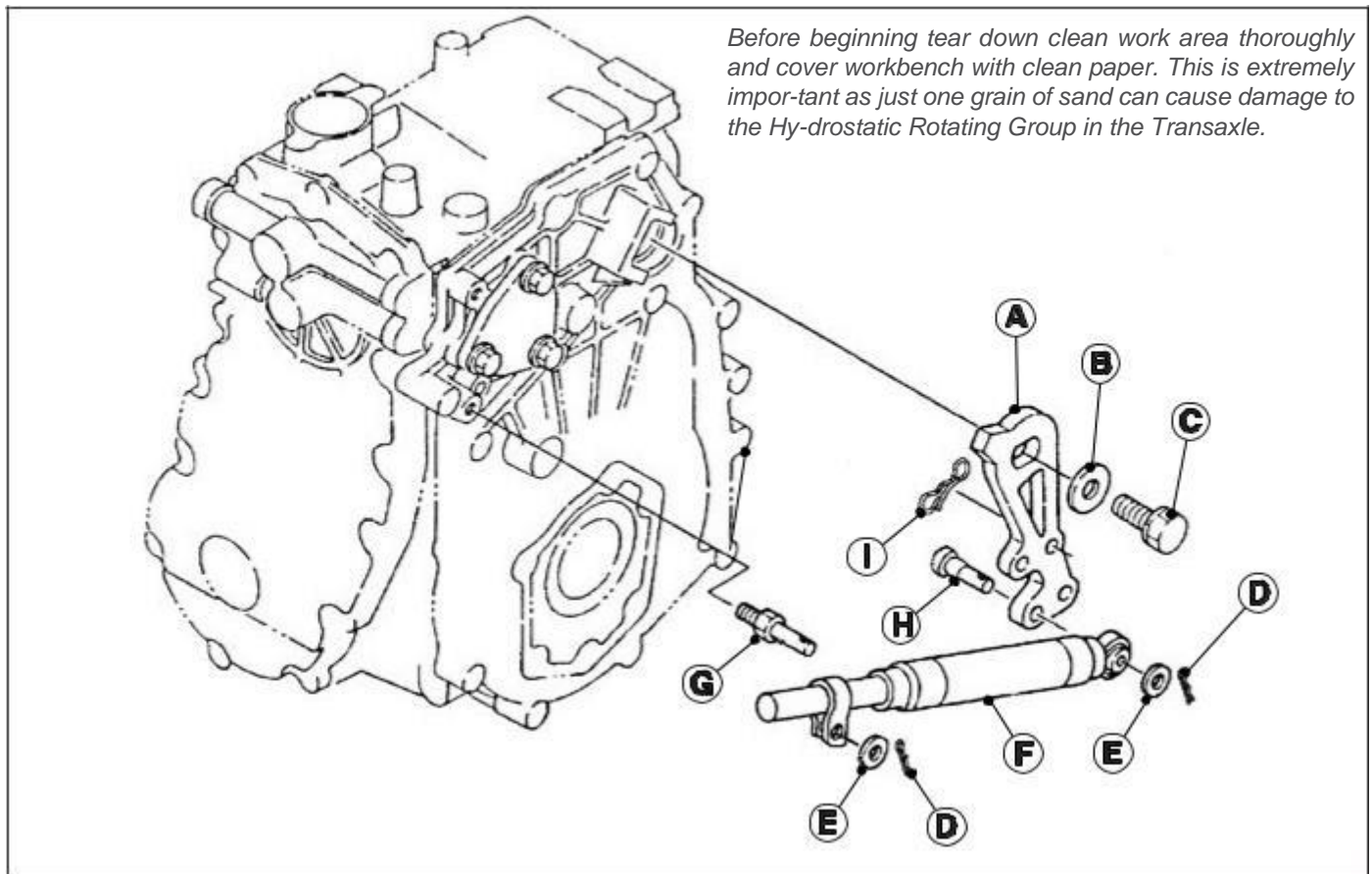

Fig. 1, Control Arm and Damper Disassembly

- A - Control Arm
- B - Washer
- C - Main Cap Screw
- D - Spring Locking Pin
- E - Washer
- F - Damper
- G - Pivot Stud
- H - Clevis Pin
- I - Spring Locking Pin

1. Remove spring locking pins (D) and washers (E) from both sides of damper (F). (Fig. 1)
2. Slide damper off of pivot stud (G) and clevis pin (H). Inspect and, if defective, replace damper as an assembly.
3. To remove control arm (A), remove spring locking pin (I) and disconnect foot control rod (D) from control arm.

4. Remove cap screw (C) and washer (B) from control arm. (Fig. 1)
5. Remove control arm (A). (Fig. 1)
6. Install control arm the same as removal, and install washer and cap screw. Tighten cap screw (C) to 73 N•m (54 lb-ft).

NOTE: If removed, use medium strength thread lock and sealer on pivot stud (G) threads.

7. Install damper with open end of clamp facing down.
8. Install remaining washers and spring locking pins.

CAUTION: ALWAYS WEAR SAFETY GLASSES WHILE PERFORMING ANY MAINTENANCE ON TRANSAXLE!

NOTE: Access to cap screw (C) is through hole in right frame.

Charge Pump Removal and Installation

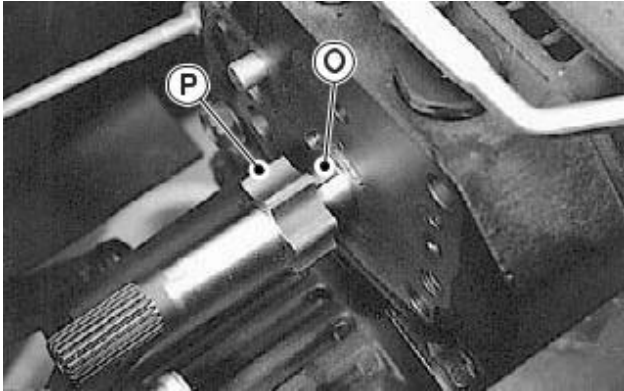

Fig. 2, Charge Pump Rotor

IMPORTANT: Avoid damage! Do not drop pump gerotor (P) or lose key (O). Damage to machined surfaces will cause poor performance and premature failure. (Fig. 2)

1. Remove drain plug to drain oil before starting any disassembly of the transaxle.
2. Remove two (2) short (A) and one long (Y) cap screw. (Fig. 3)

Charge Pump Disassembly and Assembly

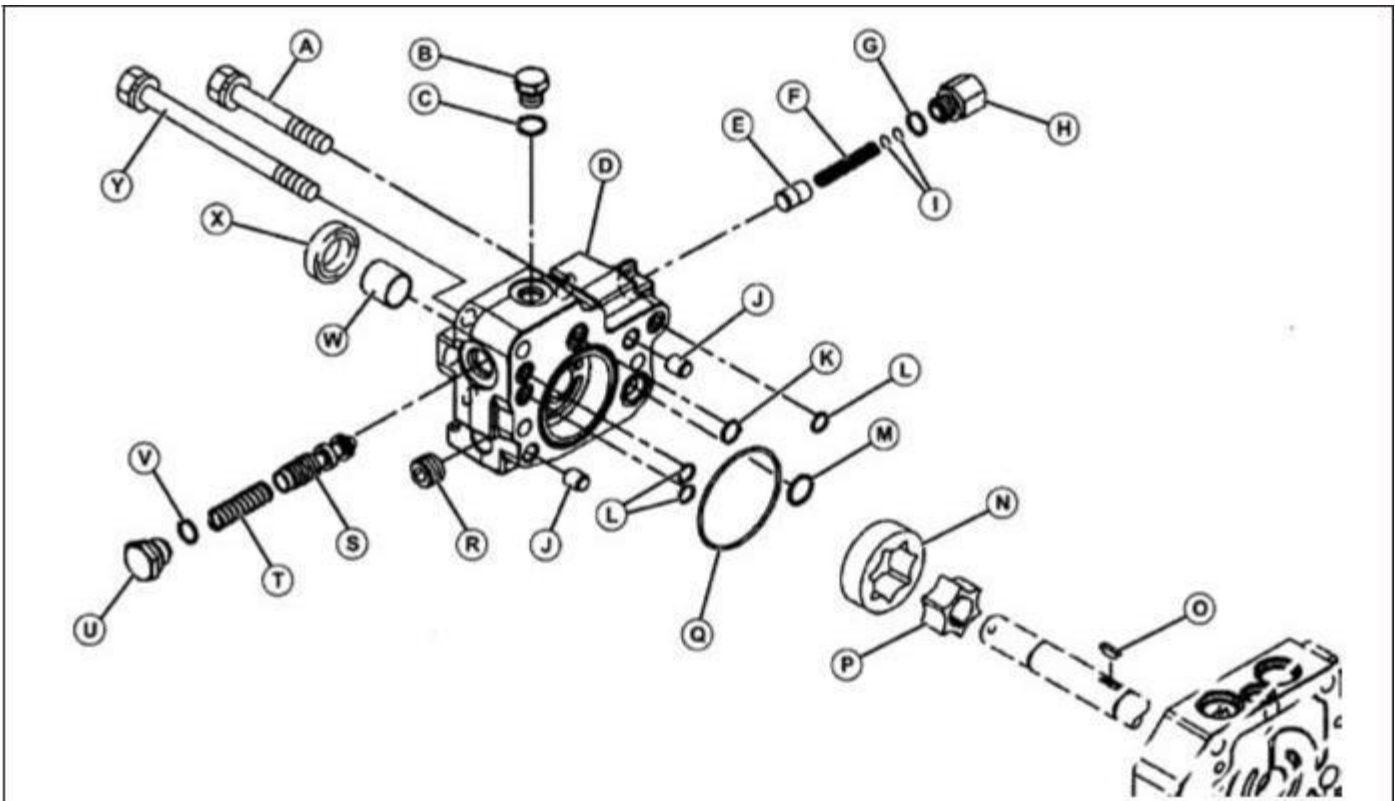

Fig. 3, Charge Pump Disassembly

NOTE: Installation is done in the reverse order of removal.

- Tighten (2) short cap screws (A) to 25 N•m (18 lb-ft).
- Tighten long cap screw (Y) to 39 N•m (29 lb-ft).

NOTE: Approximate capacity of hydrostatic power train is 7.5L (7.9 qt) for 2WD and 7.8L (8.2 qt) for 4WD and 9.0L (9.5 qt) for 4WD w/rear PTO.

Tuff Torq K92 Hydrostatic Transaxle

Charge Pump Disassembly and Assembly (continued)

A - Cap Screw (2 used), M10 x 65

B - Plug

C - O-ring

D - Pump Body

E - Pressure Valve

F - Spring

G - O-ring

H - Plug

I - Shims

J - Pin

K - O-ring

L - O-ring

M - O-ring

N - Outer Rotor

O - Key

P - Inner Rotor

Q - O-ring

R - Plug

S - Reducing Valve

T - Spring

U - Reducing Plug

V - O-ring

W - Bushing

X - Seal

Y - Cap Screw, M10 x 105

6. Check small orifice in reducing valve (S) spool for obstruction.
7. Replace parts if necessary.
8. Remove plug (H) to remove charge pressure relief valve parts (E, F, G, and I). (Fig. 3)
9. Inspect parts for scoring, wear or damage.
10. Replace parts if necessary.
11. Inspect seal (X) and bushing (W) for wear or damage.
12. If bushing is removed, apply clean hydraulic oil to bushing and use a disk driver to install bushing to bottom of bore.
13. If seal is replaced, apply clean hydraulic oil to new seal. Install seal with open side into pump body. Push seal to bottom of bore.
14. Apply clean hydraulic oil to all machined surfaces before assembly.

NOTE: Installation is done in the reverse order of removal.

NOTE: Charge pressure control valve and pressure reducing valve can be removed when the charge pump is in the machine. To inspect valve seats and bores, the pump must be removed.

1. Disassemble all parts of charge pump (D). (Fig. 3)
2. Inspect O-rings (C, K, L, M, and Q) for cuts or damage. Replace as necessary. (Fig. 3)

NOTE: Pump gerotor (N and P), seal (X), body (D), and pressure reducing valve (S) parts must be replaced as a set.

3. Inspect gerotor charge pump parts (N - P). Replace parts if worn, chipped, scored or damaged.
4. Remove plug (U) to remove pressure reducing valve parts (V, S, and T). (Fig. 3)
5. Inspect parts for scoring, wear or damage.

Directional Control Valves

Removal and Installation:

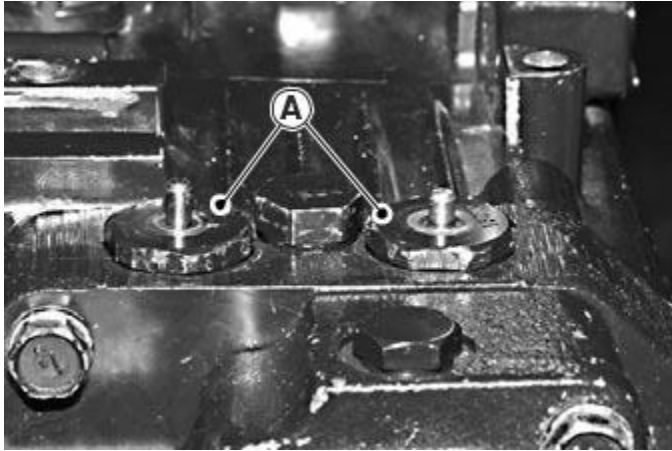

Fig. 4, Control Valves

1. Remove directional control valves (A). (Fig. 4)

NOTE: Installation is done in the reverse order of removal.

- Tighten directional control valves to 35 N•m (26 lb-ft).

Disassembly, Inspection and Assembly:

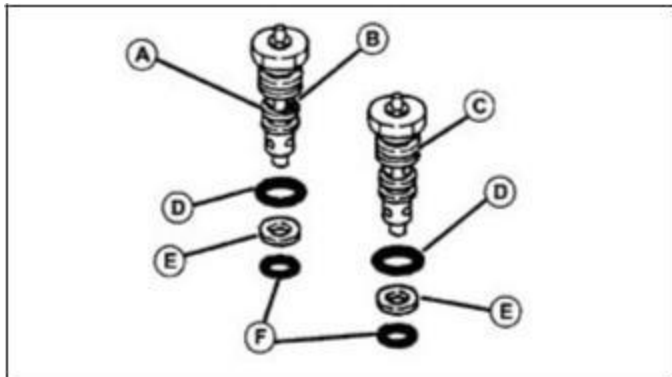

Fig. 5, Control Valve Disassembly

- A - Reverse Control Valve (with orifice)
- B - Orifice
- C - Forward Control Valve
- D - O-ring
- E - Backup Ring
- F - O-ring

1. Disassemble parts from directional control valves.
2. Inspect O-rings and backup rings for damage.

3. Plunger pin must move freely.
4. Internal valve must move freely when valve is shaken.
5. Make sure orifice and all passages are free of any obstruction.
6. Assemble parts.

IMPORTANT: Avoid damage! The reverse control valve must be installed in the left port. The control valve can be identified by a small orifice drilled into a land between the two sets of valve passageways.

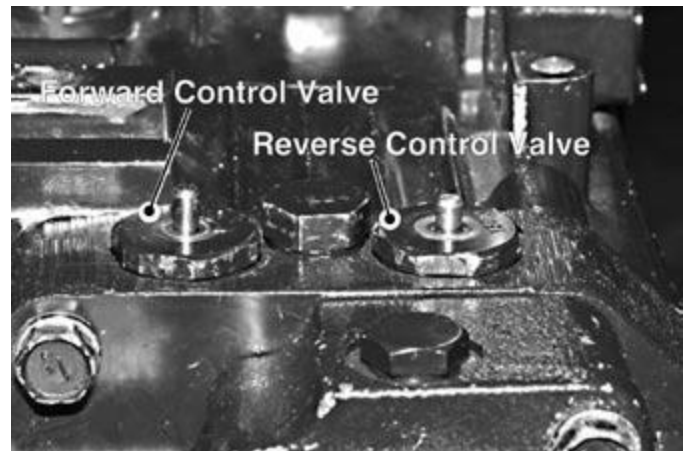

Fig. 6, Control Valve Location

PTO Solenoid Valve

Removal and Installation:

IMPORTANT: Avoid damage! Do not bend, twist or damage solenoid armature. Do not damage machined surfaces or sharp edges of spool or sleeve. PTO will not function or will function erratically if spool, sleeve or armature is damaged.

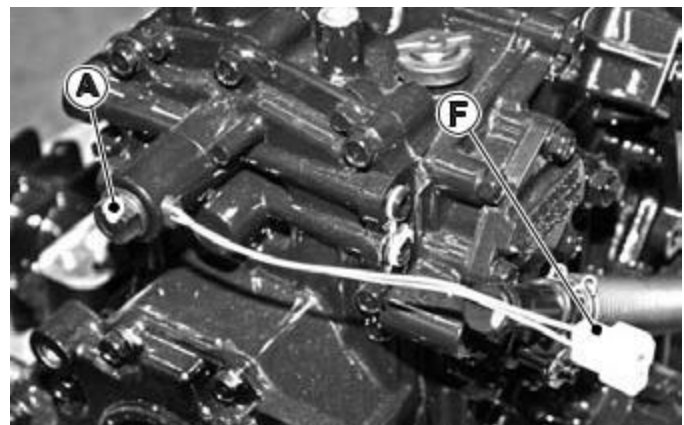

Fig. 7, Charge Pump Rotor

1. Disconnect solenoid connector (F) from wiring harness. (Fig. 7)
2. Remove nut (A) and O-ring (B). (Fig. 8)

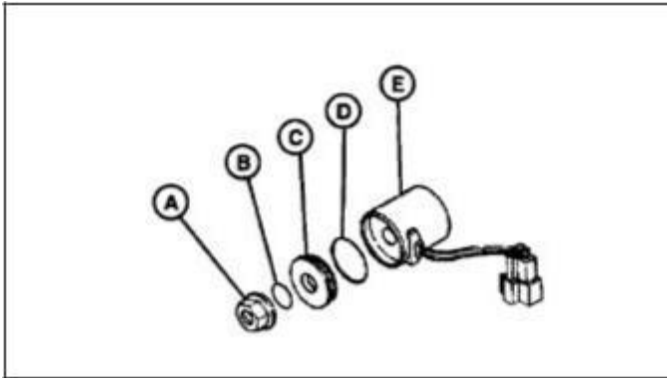

Fig. 8, Solenoid Coil Disassembly

3. Remove solenoid cover (C), O-ring (D), and solenoid coil (E). Note order and direction of valve components for reassembly.
4. Remove solenoid armature assembly. (Fig. 9)
5. Carefully remove valve components from PTO cover.

NOTE: Check bottom of bore for “wave” washer.

6. Clean and inspect parts for damage. Replace if necessary.
7. Place wave washer in case cover.

Disassembly, Inspection and Assembly:

NOTE: Sleeve and spool must be replaced as a set.

IMPORTANT: Avoid damage! Be sure large land (H) on sleeve and oil hole in spool are facing away from PTO case cover.

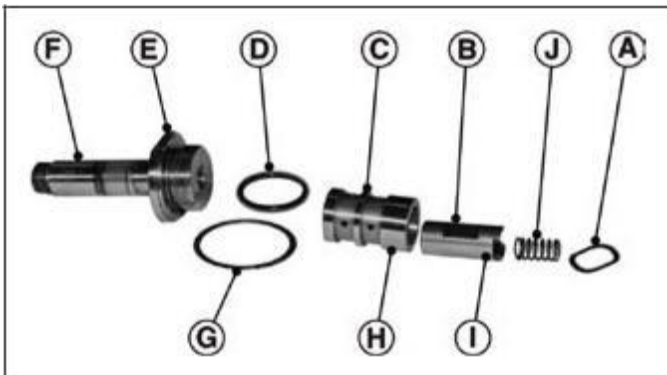

Fig. 9, PTO Solenoid Armature Disassembly

- A - Wave Washer
- B - Spool
- C - Sleeve
- D - O-ring
- E - Flats
- F - Solenoid Armature
- G - Gasket
- H - Large Land on Sleeve
- I - Oil Hole
- J - Spring

1. Disassemble PTO solenoid valve.
2. Inspect parts for wear or damage.
3. Install spool into sleeve so the end with the oil hole is toward the large land on the sleeve.
4. Place spring into recess in end of spool.
5. Install sleeve assembly so smaller lands go into the PTO cover first.
6. Install gasket and O-ring.

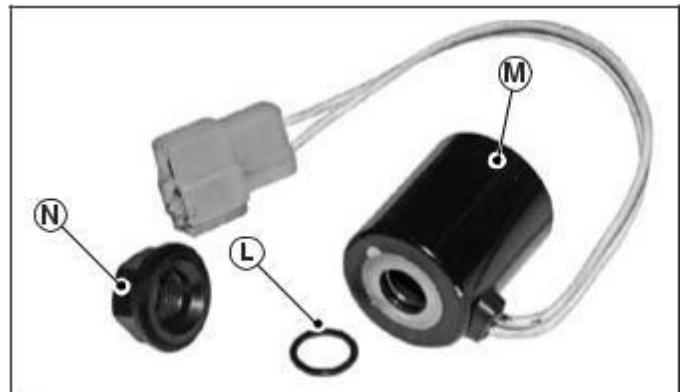

Fig. 10, Solenoid Coil

7. Tighten solenoid armature to 22 N•m (195 lb-in.).
8. Slide solenoid coil (M) onto solenoid armature. Install O-ring (L) and plastic nut (N) (do not tighten plastic nut at this time.) (Fig. 10)

- Position solenoid coil wire leads (P) to the right and approximately 45° above horizontal.

IMPORTANT: Avoid damage! When tightening plastic nut be sure to tighten nut to exact specifications. Nut has a very low torque. Any overtightening will damage the armature coil.

- Tighten plastic nut (O) to 4.9 N•m (43 lb-in.). (Fig. 11)

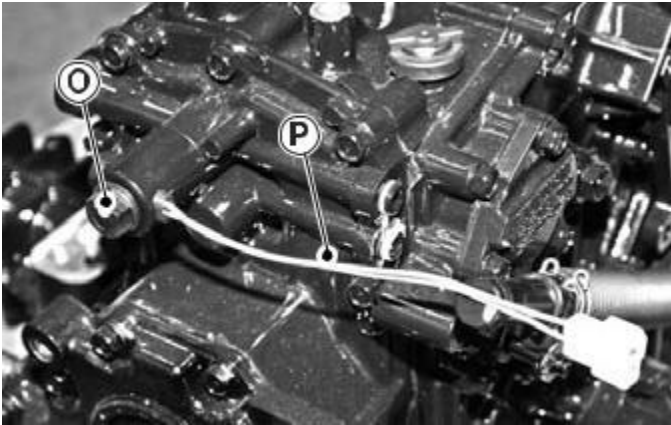

Fig. 11, PTO Electrical Solenoid

PTO Relief Valve Removal and Installation

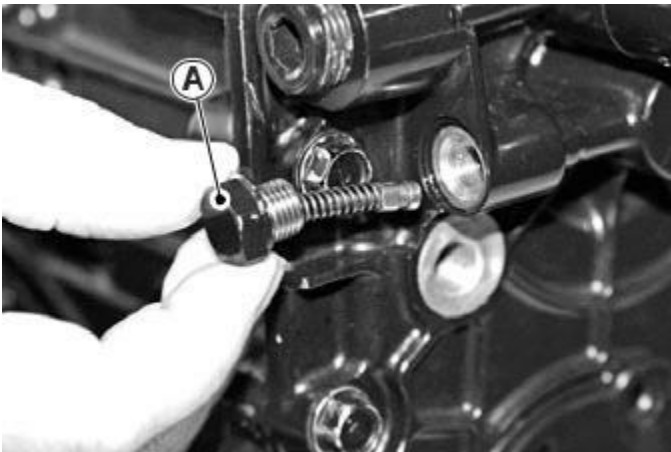

Fig. 12, Relief Valve Plug

- Remove relief valve plug. (Fig. 12)
- Install relief valve plug (A) and tighten to 25 N•m (19 lbft).

PTO Relief Valve Disassembly, Inspection and Assembly

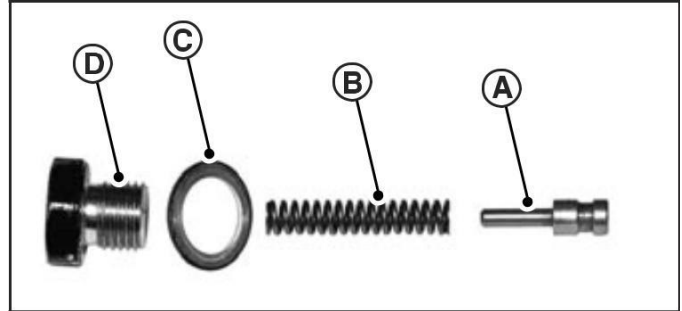

Fig. 13, Relief Valve Assembly

- Disassemble PTO relief valve. (Fig. 13)
- Check relief valve plunger and bore for scoring, nicks or burrs. Replace if necessary.
- Install spring (B), gasket (C), relief valve plunger (A), and plug (D) in PTO cover. (Fig. 13)

PTO Brake Removal and Installation

NOTE: Approximate capacity of hydrostatic power train is 7.5L (7.9 qt) for 2WD and 7.8L (8.2 qt) for 4WD and 9.0L (9.5 qt) for 4WD w/rear PTO.

CAUTION: Avoid Injury! Allow transaxle to cool before draining fluid. Hot fluid can cause serious burns.

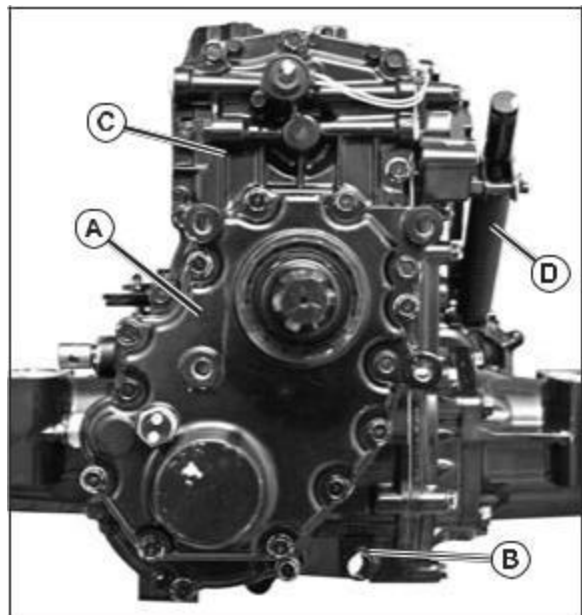

Fig. 14, Transaxle/Rear PTO Cover

Tuff Torq K92 Hydrostatic Transaxle

1. Remove plug (B) to drain oil from transaxle. (Fig. 14)

NOTE: If rear PTO is installed, remove necessary rear PTO components before rear transaxle cover removal. (See "Rear PTO Removal and Installation" on page 12.)

2. Remove optional rear PTO (A), if installed. (See "Rear PTO Removal and Installation" on page 12.) (Fig. 14)
3. Remove rear transaxle cover (C). (Fig. 14)
4. Remove control arm damper (D), (Fig. 14-15), to gain access to (3) cap screws (K), (Fig. 15), holding PTO brake cover (J), (Fig. 15), to transaxle side cover. (See "Control Arm and Damper Removal and Installation" on page 1.)

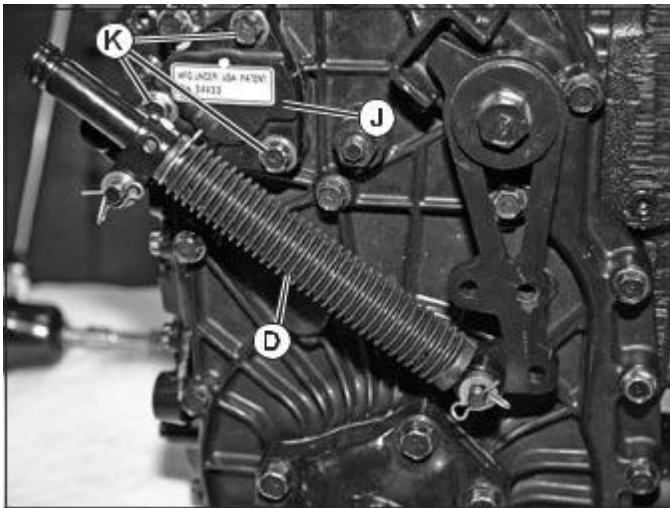

Fig. 15, PTO Brake Cover Removal



Fig. 16, PTO Brake Cover Kit

NOTE: Installation is done in the reverse order of disassembly.

PTO Brake Disassembly, Inspection and Assembly (Fig. 17)

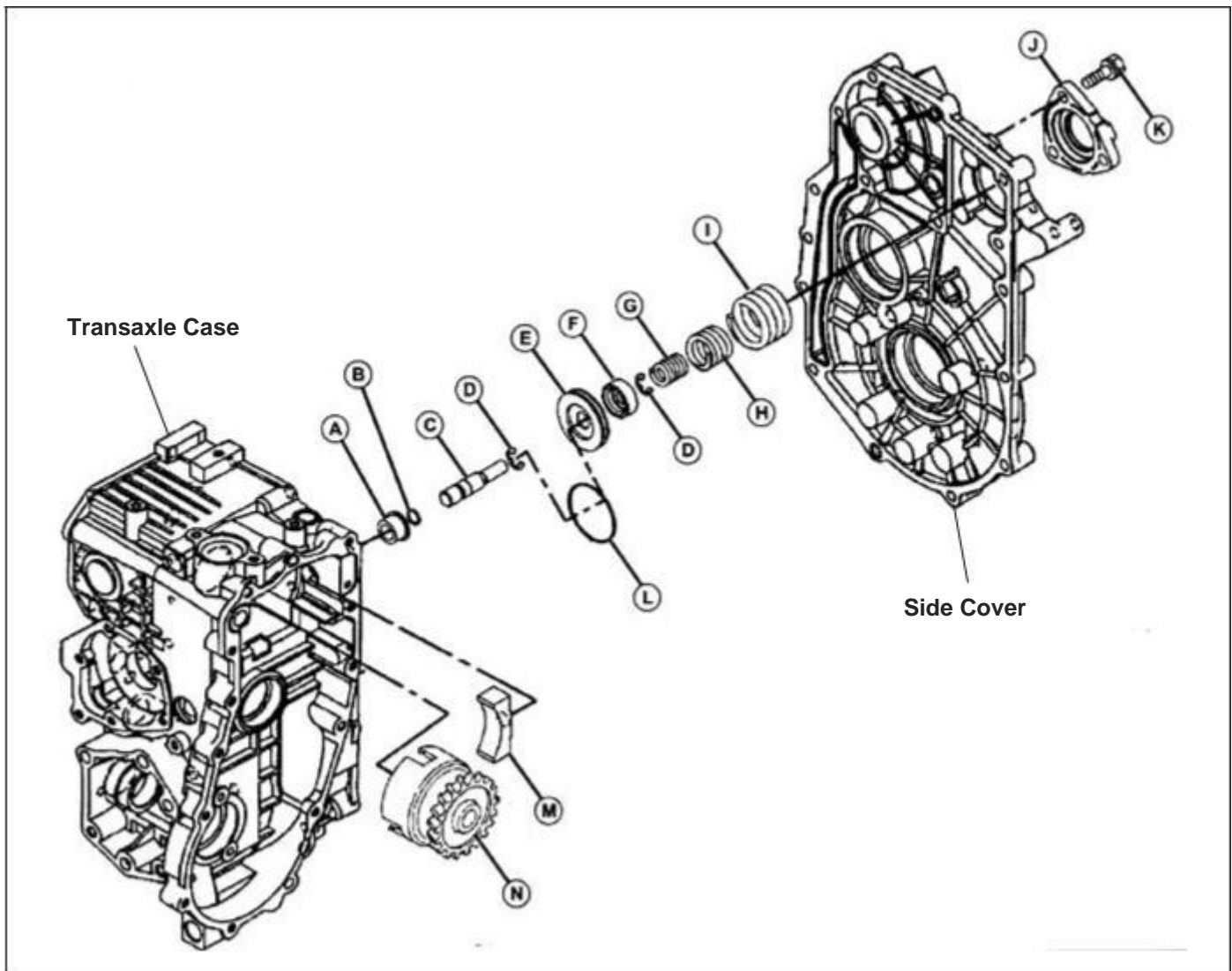

Fig. 17, PTO Brake Disassembly

CAUTION: Avoid Injury! PTO brake cover is spring loaded.
Remove cap screws evenly to release spring force.

- A - Collar, Brake Pin
- B - O-ring
- C - Pin, PTO Brake
- D - Snap Ring (2 used)
- E - Piston

- F - Stopper
- G - Spring, Inner
- H - Spring, Middle
- I - Spring, Outer
- J - Cover
- K - Cap Screw (3 used)

L - O-ring

M - PTO Brake Shoe

N - PTO Clutch Assembly

1. Carefully pull piston assembly from case using a pliers. Do not damage pin. (Fig. 17)
2. Remove PTO clutch assembly (N) and brake shoe (M) together.

NOTE: PTO brake pin, piston, springs, and O-rings, etc., (parts C thru I), must be replaced as a set.

3. Check pin and piston for burrs, scoring or wear.
4. Replace brake shoe if grooves in shoe contact surface are not visible.
5. Inspect O-rings for cuts or damage.
6. Inspect springs for cracks or damage.
7. Apply petroleum jelly to O-rings and seal on end of PTO clutch shaft.
8. Install piston assembly and clutch assembly.
9. Clean mating surface of side cover and transaxle case. Be sure threaded holes are clean.
10. Apply a bead of silicon sealant to cover mating of surface.

IMPORTANT: Avoid damage! Be sure side cover is aligned with transaxle case and installed within 3 mm (1/8 in.) of case before tightening cap screws. Major damage can occur to cover and/or case if cover is not installed properly before tightening cap screws.

Transaxle Cover Cap Screw Torque Specifications:

- Used Transaxle Case 25 N•m (18 lb-ft)
- New Transaxle Case 30 N•m (22 lb-ft)

PTO Drive Train (Mid-PTO) Removal and Installation

NOTE: Approximate capacity of hydrostatic power train is 7.5L (7.9 qt) for 2WD and 7.8L (8.2 qt) for 4WD and 9.0L (9.5 qt) for 4WD w/rear PTO.

Removing:

CAUTION: Avoid Injury! Allow transaxle to cool before draining fluid. Hot fluid can cause serious burns.

1. Remove plug (B) to drain oil from transaxle. (Fig. 18)

NOTE: Remove necessary rear PTO components before rear transaxle cover removal. (See "Rear PTO Removal and Installation" on page 14.)

2. Remove optional rear PTO (A), if installed. (See "Rear PTO Removal and Installation" on page 14.) (Fig. 18)
3. Remove rear transaxle cover (C). (Fig. 18)

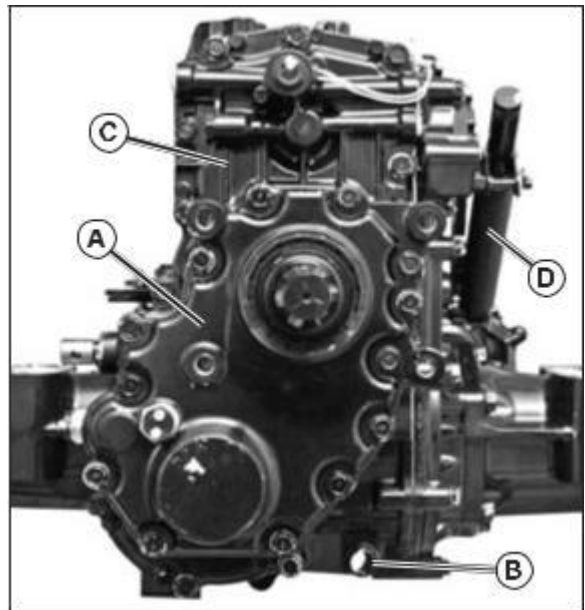

Fig. 18, Transaxle Cover

4. Remove PTO clutch assembly (A). (Fig. 19)
5. Remove PTO idler gear assembly (N). (Fig. 19)
6. Remove PTO gear (K). (Fig. 19)
7. Left axle must be removed to remove PTO output shaft assembly (L), (See "Rear Axle Assembly Removal and Installation" on page 41.)

PTO Drive Train (Mid-PTO) Removal and Installation (continued)

8. Inspect ball bearings and needle bearing for smooth rotation.

NOTE: Idler gear (N) and shaft (O) must be replaced as a set. (Fig. 19)

9. Inspect gears and splines for missing or chipped teeth, wear or damage. Replace parts if necessary.

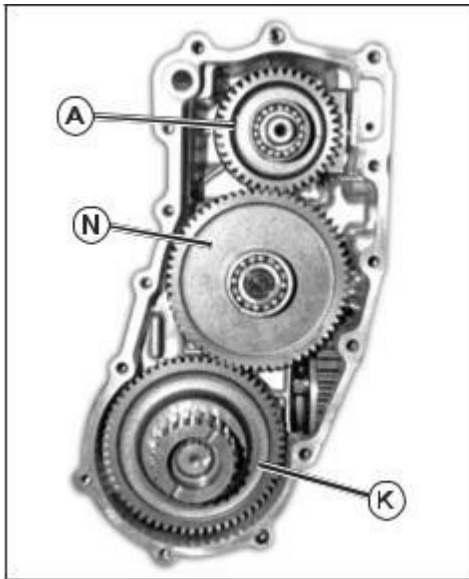

Fig. 19, Rear PTO Cover Removed

- A - PTO Clutch Assembly
- B - Snap Ring
- C - Needle Bearing
- D - Washer
- E - Seal
- F - Needle Bearing
- G - Washer
- H - Cap Screw
- I - Ball Bearing
- J - Snap Ring
- K - Mid-Mount PTO Gear
- L - PTO Output Shaft
- M - Snap Ring
- N - PTO Idler Gear
- O - PTO Idler Shaft
- P - Washer

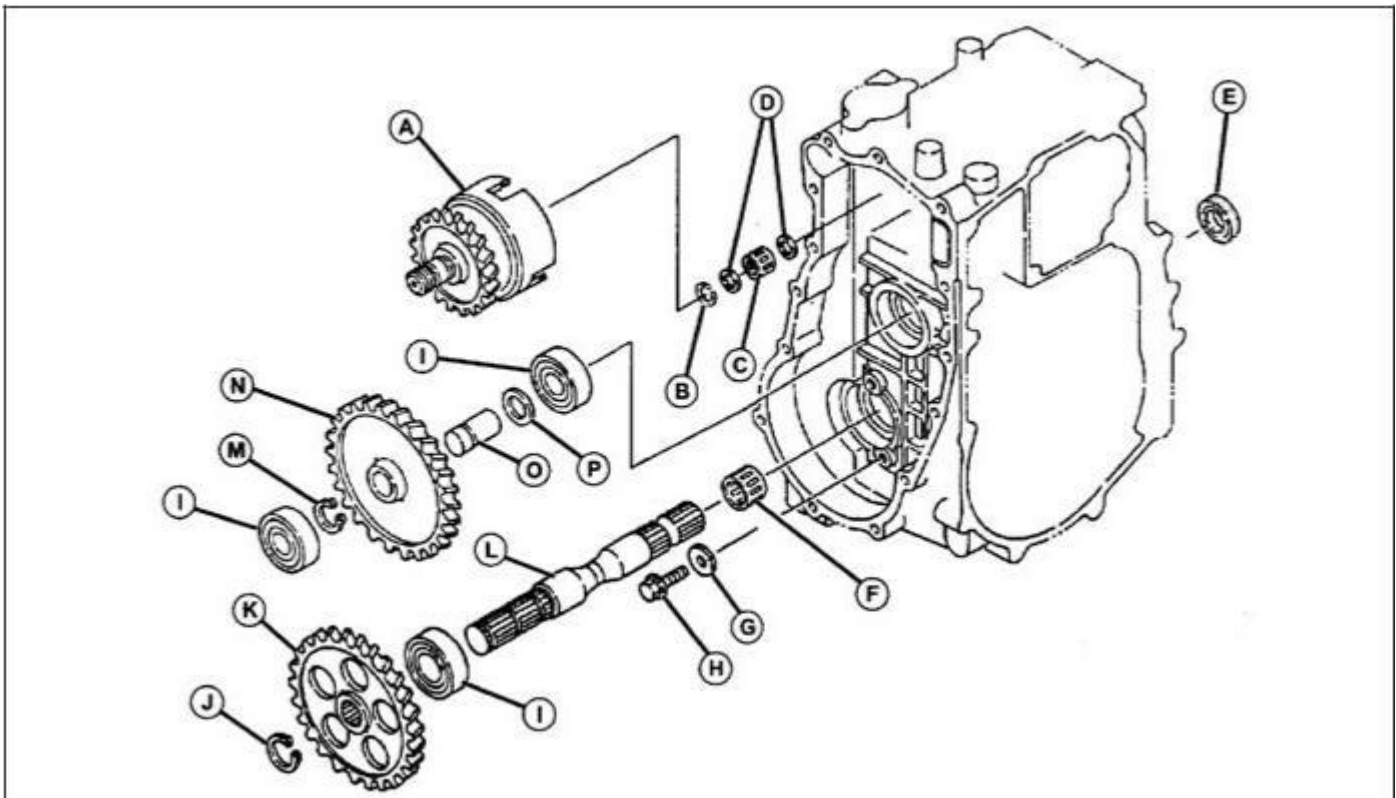

Fig. 20, PTO Drive Train (Mid-PTO) Disassembly

Installing:

1. If replaced, install new needle bearing (F) from inside case with bearing identification marks toward the inside of the case. Push bearing tight against shoulder in bore. (Fig. 20)
2. Install new seal (E) with the open, spring side towards the inside of the case. (Fig. 20)
3. Push seal against shoulder in bore.
4. Install mid-mount PTO gear (K) so side with the longer center hub is towards bearing. (Fig. 20)
5. Clean mating surfaces of rear cover and case. Be sure threaded holes are clean and two O-rings are in position in rear cover.
6. Apply petroleum jelly to seal on shaft of PTO clutch assembly.
7. Apply a bead of silicon sealant to cover mating surface.

IMPORTANT: Avoid damage! Be sure rear cover is aligned with transaxle case and installed within 4 mm (1/8 in.) of case before tightening cap screws. Major damage can occur to cover and/or case if cover is not installed properly before tightening cap screws.

8. Install transaxle drain plug. Refill transaxle with approximately 9.0L (9.5 qt) using ATF Type F as required) to crosshatched area of dipstick.

Rear Cover Cap Screw Torque Specifications:

- Used Transaxle Case 25 N•m (18 lb-ft)
- New Transaxle Case. 30 N•m (22 lb-ft)
- Internal Cap Screws. 27 N•m (20 lb-ft)

PTO Drive Train (Mid and Rear PTO) Removal and Installation

NOTE: Approximate capacity of hydrostatic power train is 7.5L (7.9 qt) for 2WD and 7.8L (8.2 qt) for 4WD and 9.0L (9.5 qt) for 4WD w/rear PTO.

Removing:

CAUTION: Avoid Injury! Allow transaxle to cool before draining fluid. Hot fluid can cause serious burns.

1. Remove plug to drain oil from transaxle (AA). (Fig. 21)

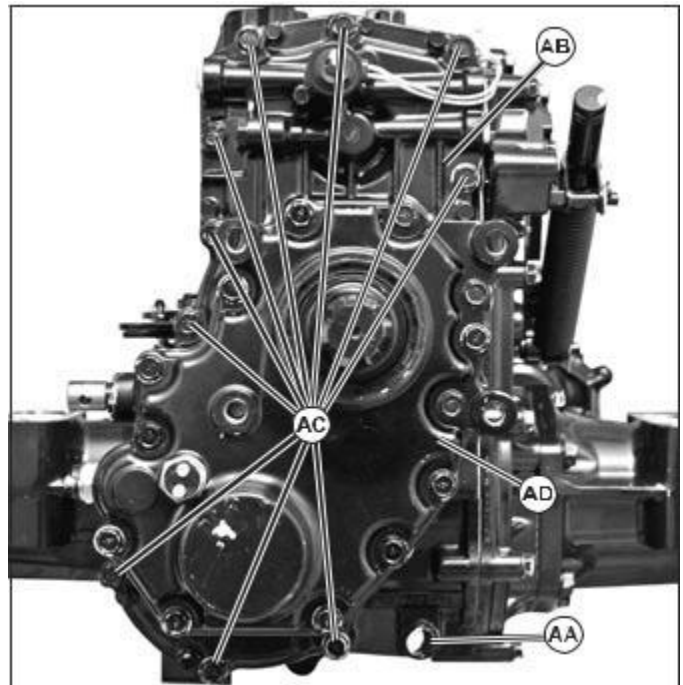

Fig. 21, PTO Drive Train (Mid and Rear PTO) Removal

NOTE: Remove necessary rear PTO components before rear transaxle cover removal. (See “Rear PTO Removal and Installation” on page 14.)

2. Remove rear PTO (AD). (See “Rear PTO Removal and Installation” on page 14.)
3. Remove (9) cap screws (AC) to remove rear cover (AB). (Fig. 21)
4. Remove PTO clutch assembly (A). (Fig. 22)

IMPORTANT: Avoid damage! When removing snap ring (B), be sure not to lose needle bearing (C) or washers (D).

5. Remove PTO idler gear assembly (U). (Fig. 22)
6. Remove snap ring (L), spline collar (K), and remove mid-mount and rear-mount PTO gear assembly (I). (Fig. 22)
7. Left axle must be removed to remove PTO output shaft assembly (R), (Fig. 20). Inspect ball bearings and needle bearings for smooth rotation.

PTO Drive Train (Mid and Rear PTO) Removal and Installation (continued)

8. Inspect gears and splines for missing or chipped teeth, wear or damage. Replace parts if necessary.

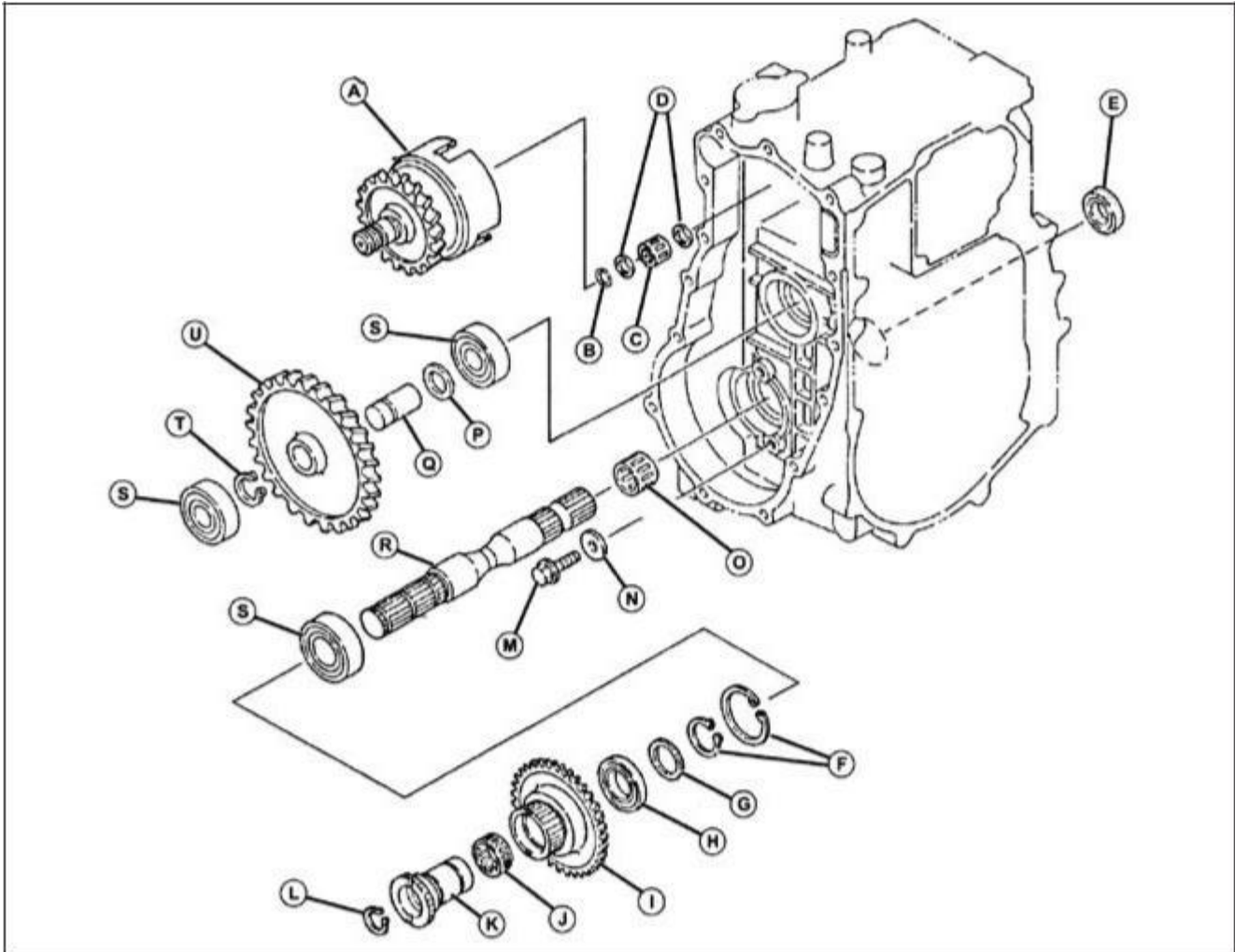

Fig. 22, PTO Drive Train (Mid and Rear PTO) Disassembly

- | | |
|---------------------------------------|------------------------|
| A - PTO Clutch Assembly | K - Spline Collar |
| B - Snap Ring | L - Snap Ring |
| C - Needle Bearing | M - Cap Screw (2 used) |
| D - Washer | N - Washer |
| E - Seal | O - Needle Bearing |
| F - Snap Ring | P - Washer |
| G - Spacer | Q - PTO Idler Shaft |
| H - Ball Bearing | R - PTO Output Shaft |
| I - Mid-Mount and Rear-Mount PTO Gear | S - Ball Bearing |
| J - Needle Bearing | T - Snap Ring |
| | U - PTO Idler Gear |

Tuff Torq K92 Hydrostatic Transaxle

Installing:

1. Clean mating surfaces of rear case and transaxle case. Be sure threaded holes are clean. (Fig. 23)
2. Apply petroleum jelly to seal on shaft of PTO clutch assembly (E). (Fig. 22)
3. Apply a bead of silicon sealant to rear case mating surface. (Fig. 23)

IMPORTANT: Avoid damage! Be sure rear case is aligned with transaxle case and installed within 4 mm (1/8 in.) of case before tightening cap screws. Major damage can occur to PTO case and/or transaxle case if not installed properly before tightening cap screws.

4. Carefully position the rear case (A) on the transaxle and onto the lower dowel pin (H). Use a pry bar between the PTO and frame to carefully move the PTO approximately 1.5 mm (1/16-in.) to the right to align the top of the case with the upper dowel pin (G). Secure with (14) cap screws (E). (Fig. 24)

Rear Cover Cap Screw Torque Specifications:

- Used Transaxle Case 25 N•m (18 lb-ft)
- New Transaxle Case. 30 N•m (22 lb-ft)
- Internal Cap Screws. 27 N•m (20 lb-ft)

5. Apply a bead of silicon sealant to PTO gear case (A) mating surface.
6. Carefully position the PTO cover (B) on the PTO case (A). Align the top of the cover with the upper dowel pin (F) and onto the lower dowel pin (I). Secure with (3) cap screws (C) and (10) cap screws (D). (Fig. 24)

IMPORTANT: Avoid damage! Be sure cover is aligned with transaxle case and installed within 4 mm (1/8 in.) of case before tightening cap screws. Major damage can occur to cover and/or case if cover is not installed properly before tightening cap screws.

Rear PTO Gear Case Cap Screw Torque Specifications:

- Used Transaxle Case 25 N•m (18 lb-ft)
- New Transaxle Case 30 N•m (22 lb-ft)

8. Install transaxle drain plug. Refill transaxle with approximately 9.0L (9.5 qt) using ATF Type F as required) to crosshatched area of dipstick.
9. Install any additional items removed prior to PTO.

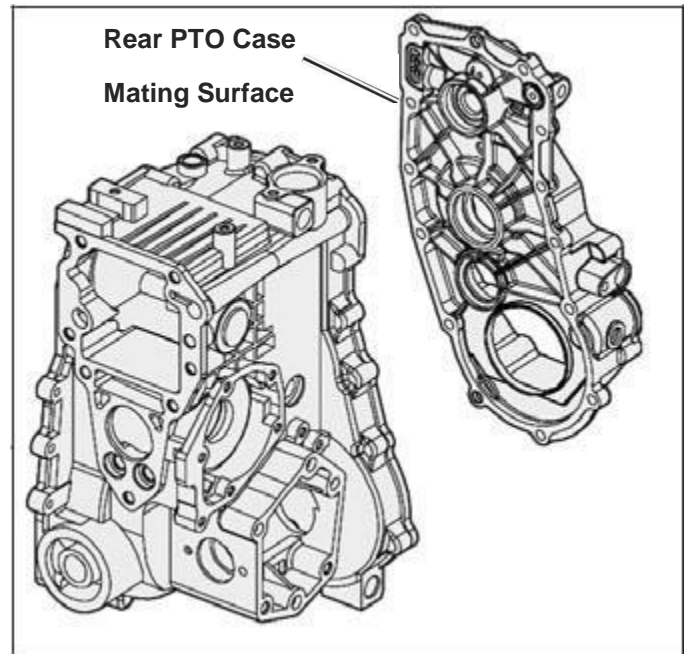

Fig. 23, Rear PTO Cover and Transaxle Case Assembly

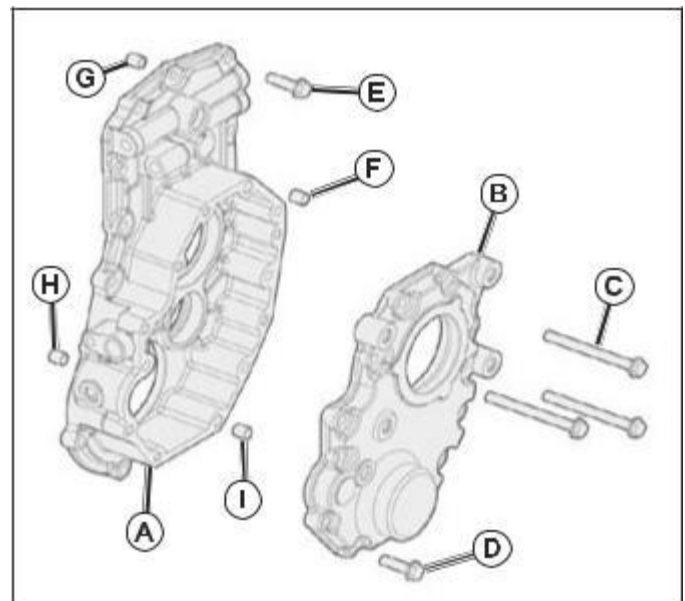

Fig. 24, Rear PTO Cover Assembly

Rear PTO Removal and Installation

NOTE: Approximate capacity of hydrostatic power train is 9.0L (9.5 qt) for 4WD w/rear PTO.

Removing:

CAUTION: Avoid Injury! Allow transaxle to cool before drain-ing fluid. Hot fluid can cause serious burns

1. Remove plug (AA) to drain oil from transaxle. (Fig. 25)

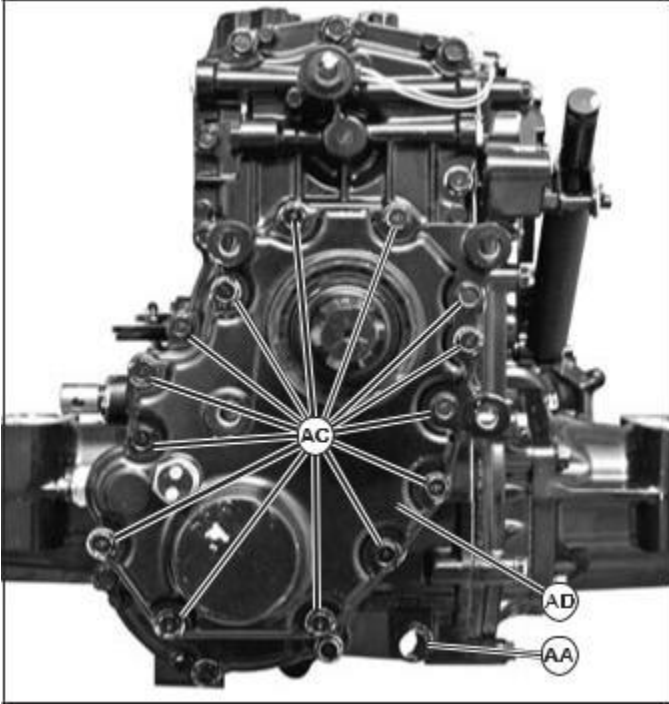

Fig. 25, Rear PTO Gear Case Cover

2. Remove (14) cap screws (AC) and PTO gear case cover assembly (AD). (Fig. 25)

NOTE: Remember to install two different sized cap screws in original holes as removed.

3. Remove PTO drive gear (G). Inspect parts and replace as necessary. (Fig. 26)
4. Remove and replace oil seal (S) from cover. Install new seal into cover with the closed side of the seal into the bore first. Use a disk driver to push seal to bottom of bore. (Fig. 26)

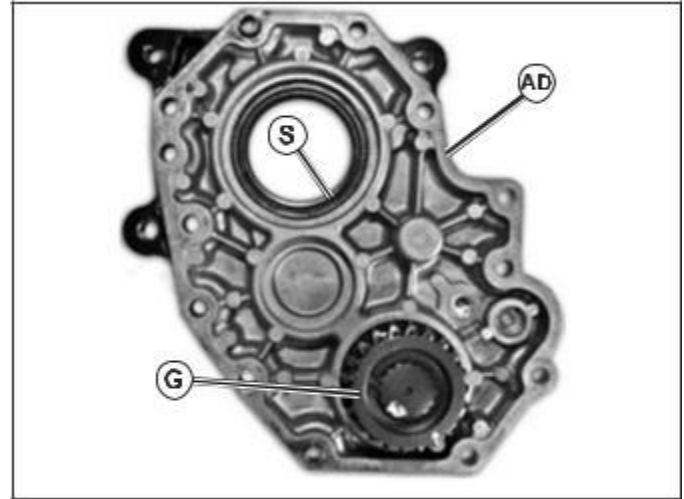

Fig. 26, PTO Rear Case Cover

Disassembly and Assembly:

1. Remove cover from PTO gear case (C). (Fig. 27)
2. Remove cap screw (A) and plate (B), and pull shifter shaft (E) from PTO gear case (C). Replace O-ring on shifter shaft and apply thin coating of clean hydraulic oil, before reinstalling. (Fig. 27)

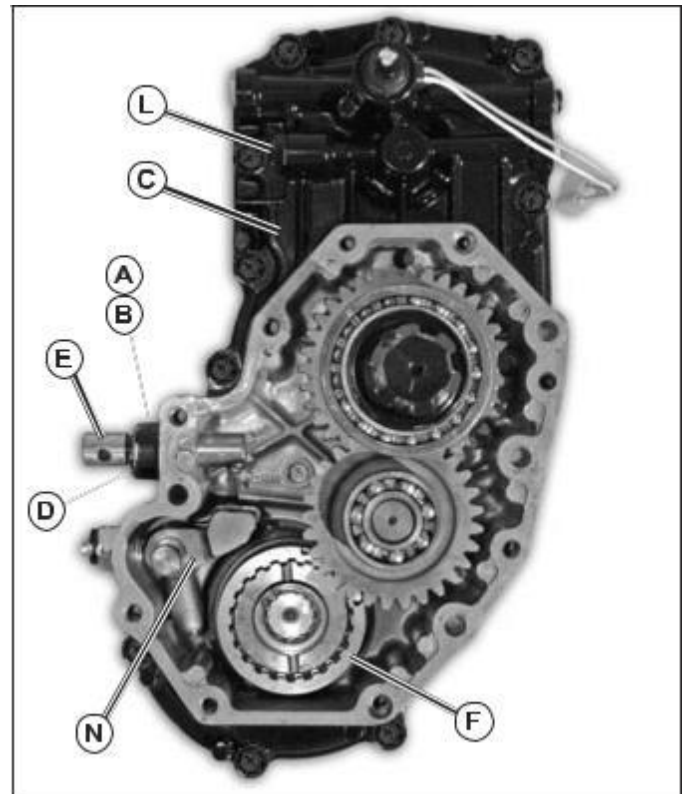

Fig. 27, Rear PTO Gear Case Assembly

Tuff Torq K92 Hydrostatic Transaxle

3. Remove shift collar (F) and shifter fork (N) assembly together. (Fig. 27)

NOTE: If shift collar replacement is necessary, the rear PTO idler gear and rear PTO input gear must be replaced also. The three gears are available as a set.

4. Remove tow relief valve (L) if necessary. Remove and replace O-ring. (Fig. 28)

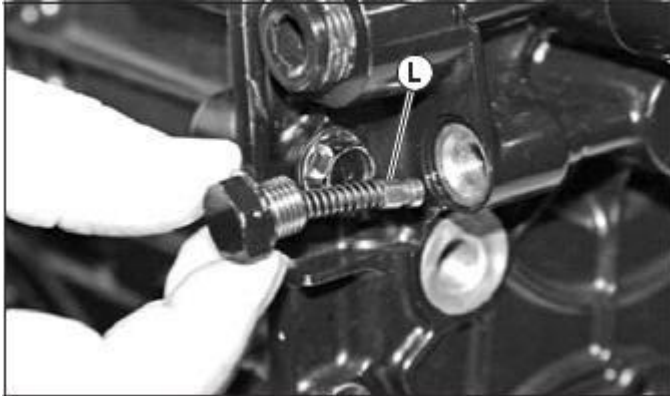

Fig. 28, Tow Relief Valve

5. Remove (10) cap screws (AC) and removal PTO rear case from transmission case. (Fig. 29)

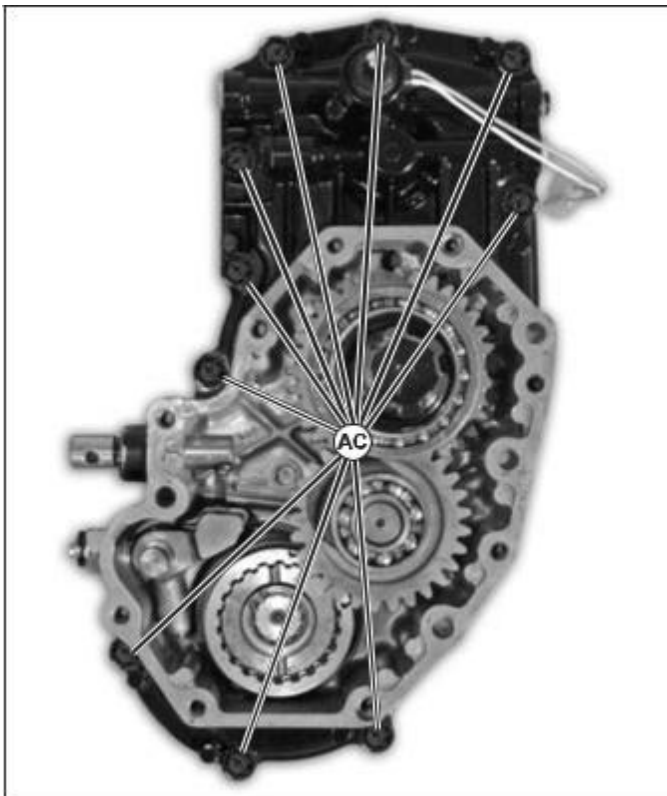

Fig. 29, Rear PTO Gear Case Removal

6. If shifter fork (N), see fig. 27, was disassembled, install spring (Y) and ball (V) in fork. While compressing ball and spring, install fork shaft (CC). Be sure ball fits into grooves of shaft. (Fig. 37)

7. With fork groove of shift collar away from case, install shifter fork and collar. Be sure arm of shifter shaft (E) fits into slot of shifter fork. (Fig. 37)

NOTE: Install bearings with writing/numbers facing gears in cover assembly.

8. Using a rubber mallet, tap the opposite side of the PTO cover to unseat the idler gear, bearings, and shaft as a single item. (Fig. 30)



Fig. 30, Idler Gear Set

9. From reverse side of PTO case, drive out the PTO idler pinion gear, PTO input gear, idle shaft, and bearings from their seated position as a single item. Press bearings from shaft and inspect all components for wear or damage, replace as necessary. (Fig. 31)



Fig. 31, Input Gear Set

10. From reverse side of the PTO case, drive out the rear PTO shaft, PTO gear, and bearings from case as a single item. (Fig. 32)

Rear PTO Removal and Installation (continued)



Fig. 32, Rear PTO Shaft Assembly

11. Remove press bearing (S) from the PTO shaft (X); then, remove PTO gear (T), snap rings (Z), and press bearing (W) from PTO shaft. Inspect all components for wear or damage, replace as necessary. (Fig. 33)

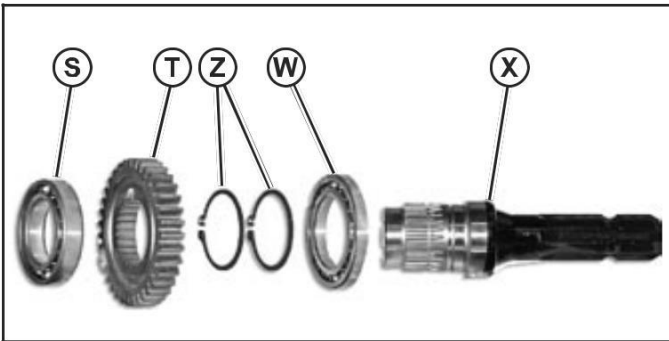

Fig. 33, Rear PTO Shaft Disassembly

12. Remove press bearing (M) from idler shaft (P). Remove washer (N), PTO input gear (R), and idler pinion gear (O). Remove press bearing (U) and remove washer (Q) from idler shaft (P). Inspect all components for wear or damage, replace as necessary. (Fig. 34)

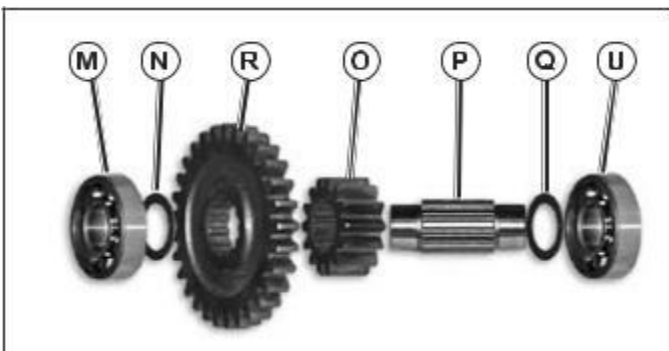

Fig. 34, Rear PTO Pinion/Input Gear Disassembly

NOTE: If rear PTO input gear (R), see fig. 34, replacement is necessary, the shift collar (F), see fig. 36, and rear PTO idler gear (G), see fig. 35, must be replaced also. The three gears are available as a set. Rear PTO gear (T), see fig. 33, and rear PTO idler pinion (O), see fig. 34, must be replaced as a set.

13. Remove snap ring (L), idler gear (G), snap ring (H), press bearing (I), and press bearing (K) from shaft (J). Inspect all components for wear or damage, replace as necessary. (Fig. 35)

NOTE: Recall writing/numbers on all outer bearing races, and install bearings in reverse order as removal.

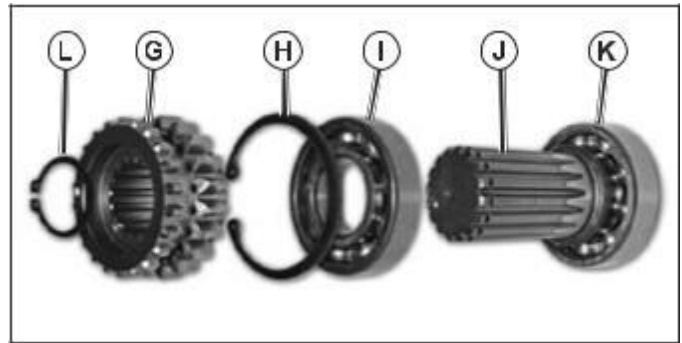

Fig. 35, Rear PTO Idler Gear Disassembly

14. If necessary, remove ball switch (W) and O-ring. (Fig. 36)

- If removed, install O-rings and ball switches (W). DO NOT overtighten. Tighten to 34 N•m (25 lb-ft).

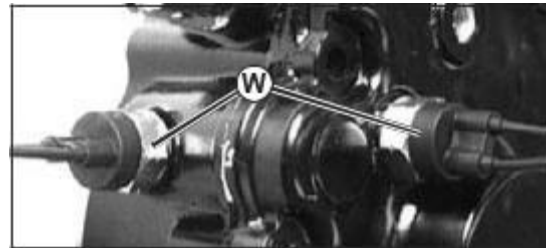

Fig. 36, Ball Switches

15. Inspect all parts and replace as necessary. Assembly is reverse order of disassembly.

Tuff Torq K92 Hydrostatic Transaxle

Rear PTO Assembly

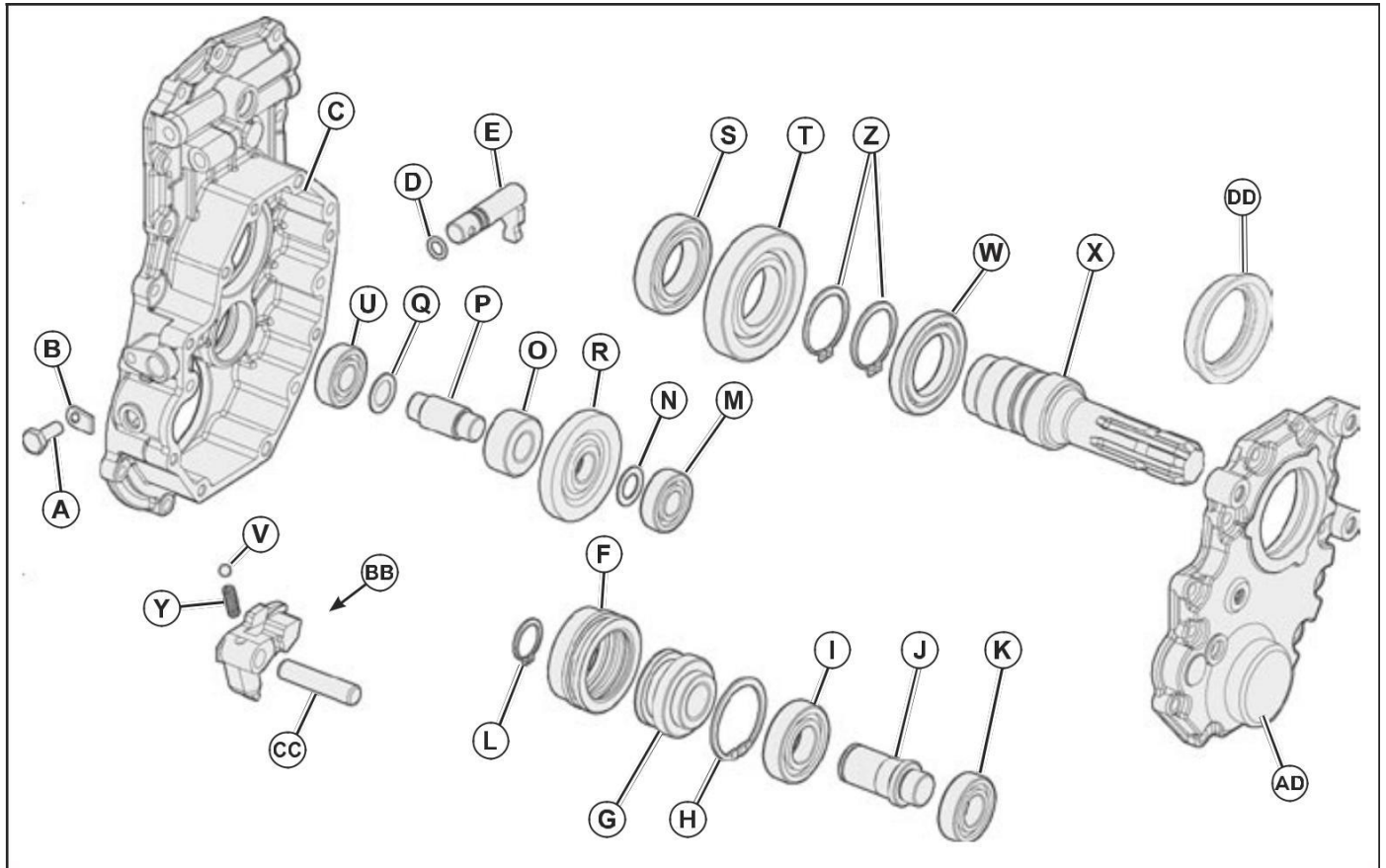

Fig. 37, Rear PTO Disassembly

- | | |
|-----------------------|---------------------|
| A - Cap Screw | P - Shaft |
| B - Spring | Q - Washer |
| C - PTO Case | R - Input Gear |
| D - O-ring | S - Bearing |
| E - Shifter Shaft | T - Rear PTO Gear |
| F - Spring | U - Bearing |
| G - Idler Gear | V - Ball |
| H - Snap Ring | W - Bearing |
| I - Bearing | X - Rear PTO Shaft |
| J - Idler Shaft | Y - Spring |
| K - Bearing | Z - Snap Rings |
| L - Snap Ring | AD - Rear PTO cover |
| M - Bearing | BB - Fork Kit |
| N - Washer | CC - Fork Shaft |
| O - Idler Pinion Gear | DD - Seal |

Rear PTO Removal and Installation (continued)

Installing:

NOTE: Installation is done in the reverse order of disassembly. Additional information can be found by referring to the "Rear PTO Removal and Installation" removal section, starting on page 14.

1. Clean mating surfaces of cover (AD) and gear case (C). Be sure threaded holes are clean. (Fig. 37)
2. If removed, install gear sets in the reverse order of their disassembly. (Fig. 37)
3. Apply a bead of silicon sealant to any mating surfaces to be assembled.

IMPORTANT: Avoid damage! Carefully lower cover assembly onto case, making sure bearings fit into bores and gears mesh properly. Be sure cover is installed within 3 mm (1/8 in.) of case before tightening all cap screws to 25 N•m (18 lb-ft). Major damage can occur to cover and/or case if not properly aligned before tightening cap screws.

4. Install PTO assembly on the two alignment bushings, and tighten ten F), and three M8 x 50 (E) cap screws to specification below.
5. Install transaxle drain plug. Refill transaxle with approximately 9.0L (9.5 qt) using ATF Type F to crosshatched area of dipstick.

Specifications:

- M8 Bolts. 24 N•m (18 lb-ft)
- M12 Bolts. 54 N•m (40 lb-ft)

Tuff Torq K92 Hydrostatic Transaxle

Differential Lock Shaft Disassembly and Assembly

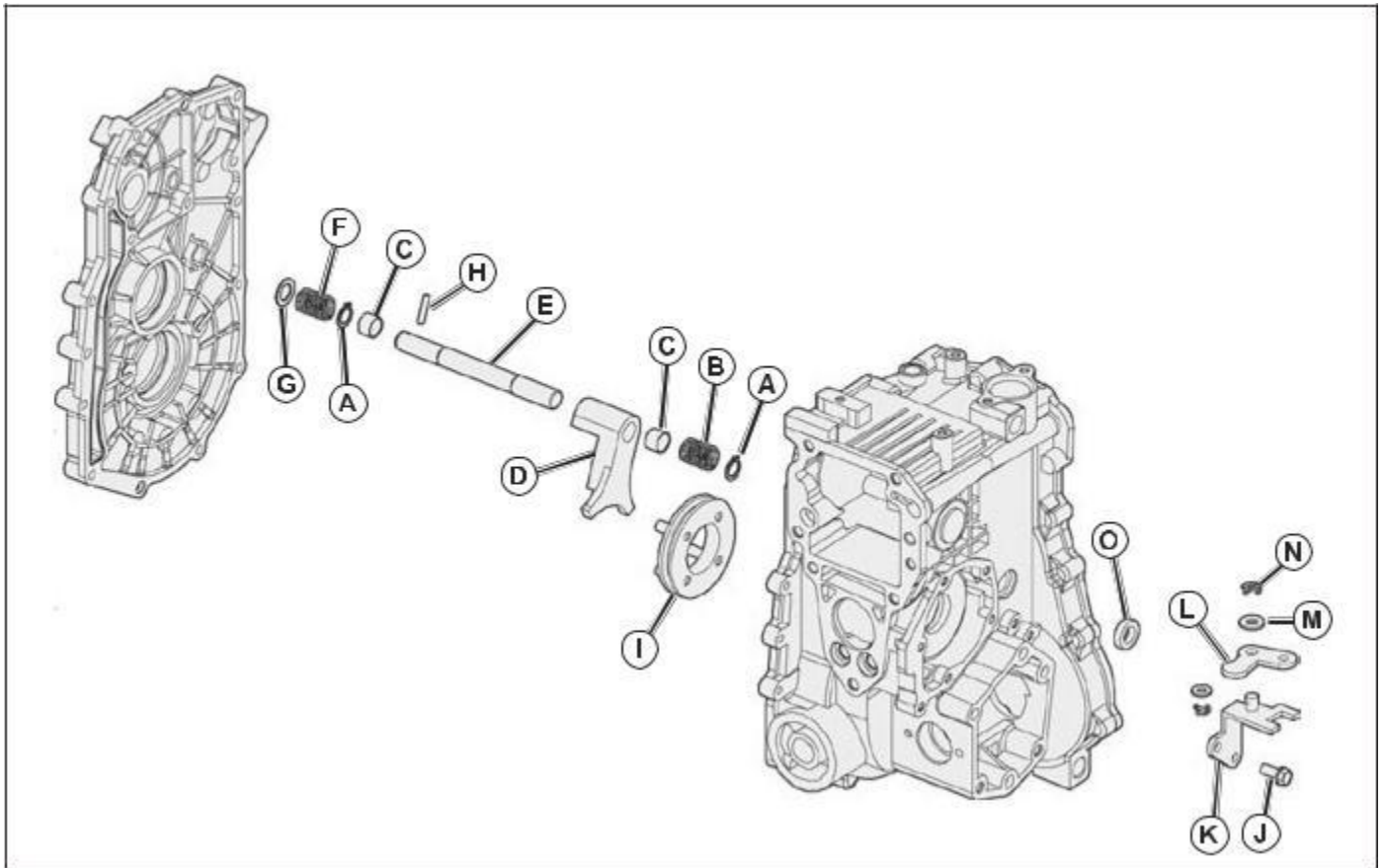

Fig. 38, Differential Lock Shaft Disassembly

A - Snap Ring (2 used)
B - Spring
C - Sleeve (2 used)
D - Fork
E - Shaft
F - Spring
G - Washer

H - Roll Pin
I - Shift Collar
J - Cap Screw
K - Plate
L - Fulcrum, Differential Lock
M - Washer
N - Cotter Pin
O - Seal

1. Remove roll pin (H), washer (G), and spring (F). (Fig. 38)
2. Remove snap rings (A), sleeves (C), spring (B), shaft (E), and fork (D). (Fig. 38)
3. Inspect shaft (E) and fork for wear or damage. Replace parts as necessary. (Fig. 38)

NOTE: Installation is done in the reverse order of removal.

NOTE: Install long hub of fork towards transaxle.

CAUTION: Avoid Injury! Springs are under compression. Carefully remove roll pin and release spring force slowly to prevent personal injury.

Differential (2WD) Disassembly and Assembly

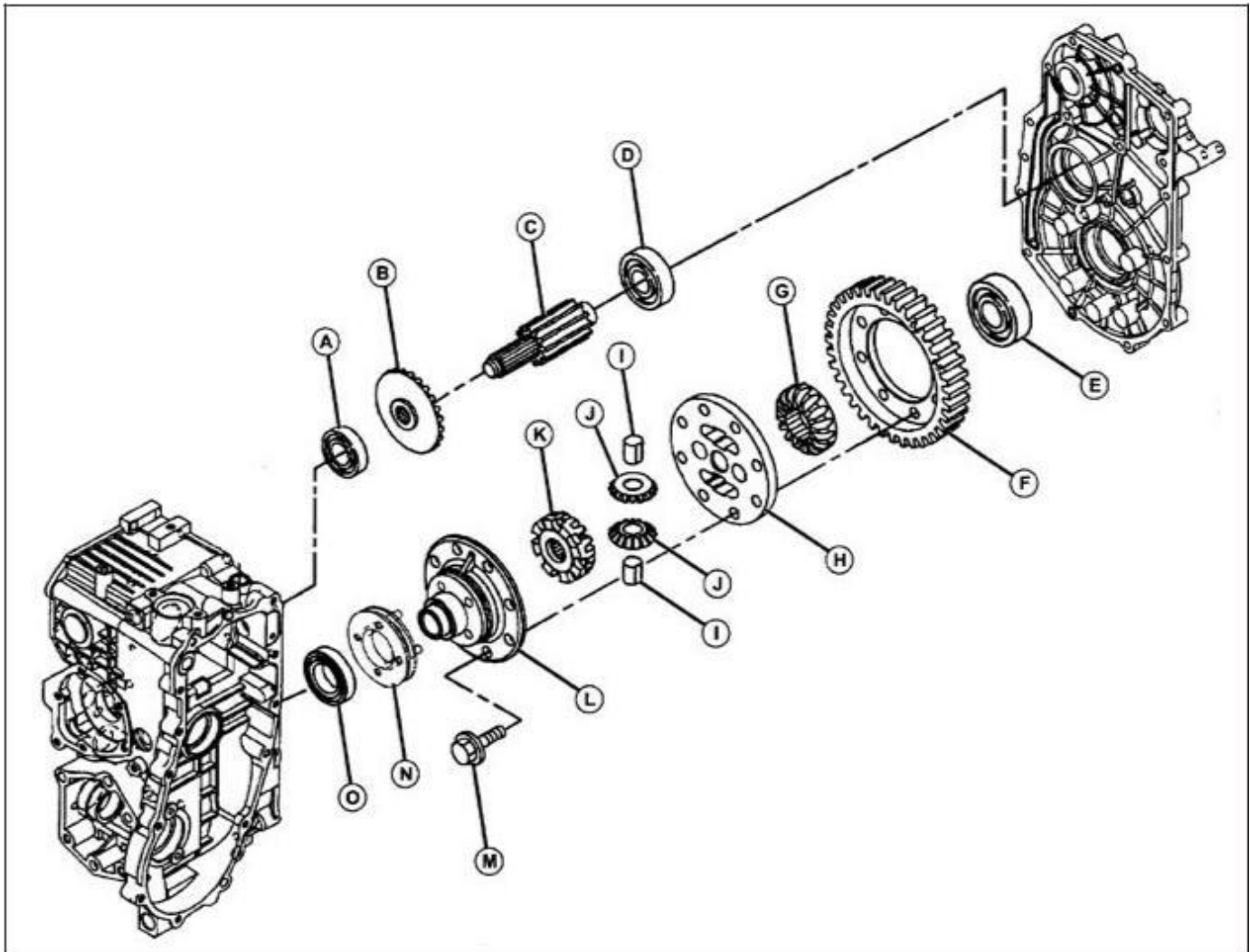

Fig. 39, Differential (2WD) Disassembly

- A - Ball Bearing
- B - Bevel Input Gear
- C - Final Pinion Shaft
- D - Ball Bearing
- E - Right Ball Bearing
- F - Final Gear
- G - Right Differential Gear
- H - Differential Carrier
- I - Pins (2 used)
- J - Pinion Gear (2 used)
- K - Left-Notched Differential Gear
- L - Differential Holder
- M - Cap Screws w/Washers (8 used)
- N - Differential Lock Collar
- O - Left Ball Bearing

1. Use a puller to remove left ball bearing from differential holder.
2. Inspect differential components.
3. Bearings must rotate free and smoothly. Replace as necessary.
4. Check differential components for wear or damage. If replacement is necessary, all parts must be replaced as set.
5. Inspect differential lock collar for wear or loose or sheared off pins.
6. Check differential holder (L) and carrier (H) for wear, cracks or damage. (Fig. 39)

7. Inspect final gear (F) for worn or damaged teeth.
(Fig. 39)
8. Inspect ball bearings (A and D) for smooth rotation.
(Fig. 39)

NOTE: Final pinion shaft (C) and final gear (F) must be re-placed as a set. Bevel input gear (B) and bevel input pinion (not shown) must be replaced as a set.

9. Check bevel input gear (B) and final pinion shaft (C) for worn or damaged condition. Replace parts as necessary.
(Fig. 39)

10. Install final gear on differential holder and carrier with the deeper offset of gear center away from the holder. Tighten eight differential cap screws (M) to 88 N•m (65 lbft).

11. Install differential lock collar (N) and left and right bearings (O). Push bearing tight against shoulder of differential holder. (Fig. 39)

12. Install remaining components.

NOTE: Use medium strength thread lock and sealer.

Differential (4WD) Disassembly and Assembly

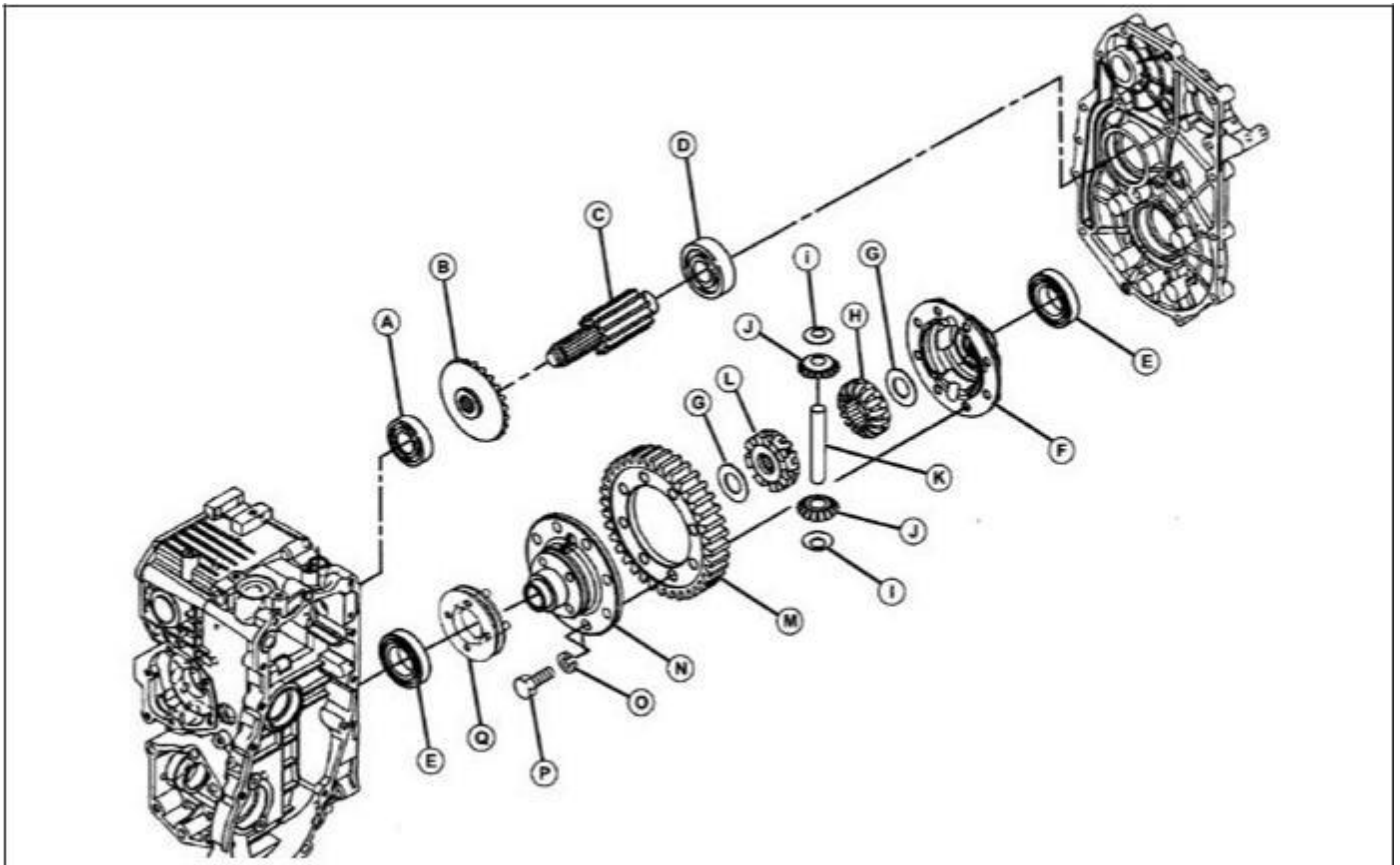

Fig. 40, Differential (4WD) Disassembly

- | | |
|--------------------------------|------------------------------------|
| A - Ball Bearing | I - Washer (2 used) |
| B - Bevel Input Gear | J - Pinion Gear (2 used) |
| C - Final Pinion Shaft | K - Differential Pinion Shaft |
| D - Ball Bearing | L - Left-Notched Differential Gear |
| E - Ball Bearing (2 used) | M - Final Gear |
| F - Differential Holder, Right | N - Differential Holder, Left |
| G - Liner (2 used) | O - Washers (8 used) |
| H - Right Differential Gear | P - Cap Screws (8 used) |
| | Q - Differential Lock Collar |

Differential (4WD) Disassembly and Assembly (continued)

1. Use a puller to remove ball bearings (E) from differential holders (F and N). (Fig. 40)
2. Inspect differential components.
3. Bearings must rotate free and smoothly. Replace as necessary.
4. Check differential components for wear or damage. If replacement is necessary, all parts must be replaced as set.
5. Inspect differential lock collar for wear or loose or sheared off pins.
6. Check differential holders (F and N) and differential pinion shaft (K) for wear, cracks or damage. (Fig. 40)
7. Inspect final gear (M) for worn or damaged teeth.

NOTE: Pinion gears (J) (2 used), washers (I) (2 used), and dif-ferential pinion shaft (K) must be replaced as a set.

8. Inspect ball bearings (A and D) for smooth rotation.

NOTE: Final pinion shaft (C) and final gear (M) must be re-placed as a set. Bevel input gear (B) and bevel input pinion (not shown) must be replaced as a set.

9. Check bevel input gear (B) and final pinion shaft (C) for worn or damaged condition. Replace parts as necessary.
10. Install final gear on differential holder and carrier with the deeper offset of gear center away from the holder. Tighten eight differential cap screws (P) to 88 N•m (65 lbft).
11. Install differential lock collar (Q) and left bearing (E). Push bearing tight against shoulder of differential holder.
12. Install remaining components.

NOTE: Use medium strength thread lock and sealer.

PTO Clutch Disassembly, Inspection and Assembly

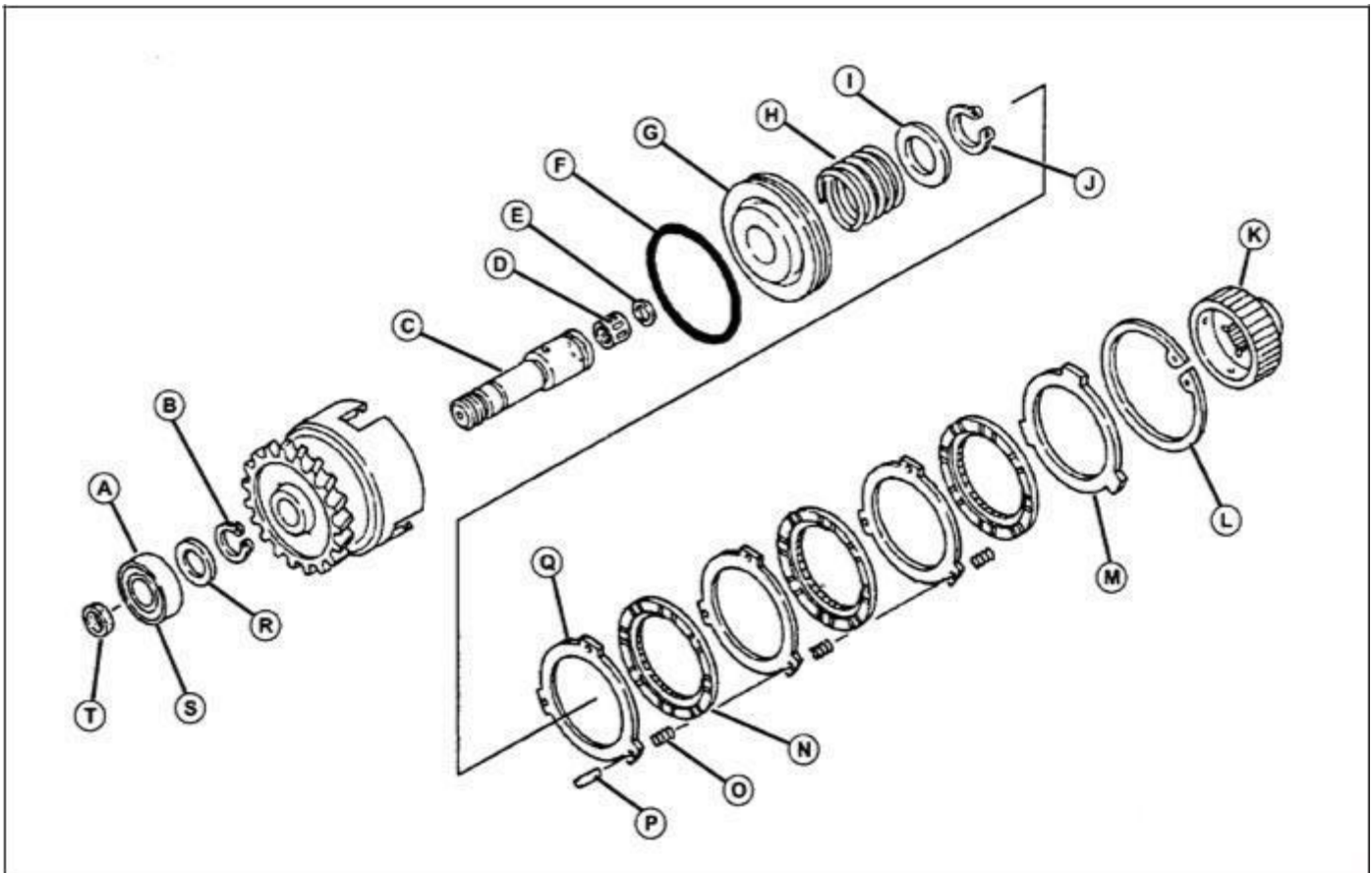

Fig. 41, PTO Clutch Disassembly

- A - Ball Bearing
- B - Snap Ring
- C - Clutch Shaft
- D - Needle Bearing
- E - Washer
- F - O-ring
- G - Piston
- H - Spring
- I - Washer
- J - Snap Ring
- K - Input Shaft Collar
- L - Snap Ring
- M - Thick Steel Plate
- N - Friction Plate
- O - Spring
- P - Pin
- Q - Steel Plate
- R - Clutch Gear/Hub
- S - Washer
- T - Seal Ring

1. Remove PTO clutch assembly. (See “PTO Brake Removal and Installation” on page 6.)
2. Remove large snap ring and thick steel plate.
3. Remove parts.

NOTE: Friction plates, springs, steel plates and pins must be replaced as a set.

4. Replace clutch gear/hub if brake surface is badly scored or teeth are chipped or damaged.

CAUTION: Avoid Injury! Piston is under spring force. Use care during disassembly.

5. Remove piston from clutch gear/hub. Use a transmission gear spacer (X) to compress spring (U) and washer (V) in a vise. Remove snap ring (W) and slowly release force of spring. (Fig. 42)
6. Remove remaining clutch parts.
7. Check bearings for smooth rotation.
8. Inspect clutch gear for worn or damaged teeth.
9. Check inner piston bore for scoring or wear.

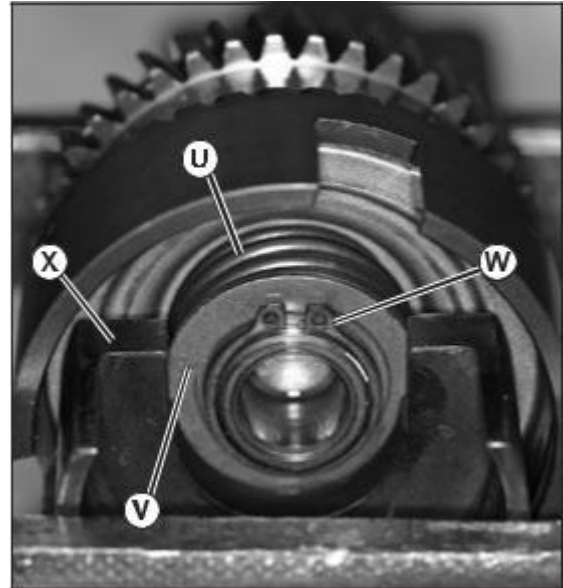

Fig. 42, Clutch Disassembly

10. Check steel plates for scoring, discoloration, warping or wear.
11. Replace worn or damaged springs.
12. Check input shaft collar for burrs, wear or damaged teeth or splines.
13. Check clutch pack wear. Assemble parts.



Fig. 43, Clutch Disassembly

14. Put clutch gear/hub on bench so steel and friction plates are against snap ring. Measure clearance between inner steel plate and bottom of clutch gear/hub.
15. If clearance measures 2.7 mm (0.106 in.) or more, re-place PTO clutch plates.
16. Apply clean hydraulic oil to all parts.

NOTE: Installation is done in the reverse order of removal.

4WD Output Disassembly and Assembly

1. Drain transaxle.

CAUTION: Avoid Injury! Allow transaxle to cool before drain-ing fluid. Hot fluid can cause serious burns.

2. Remove bolt/washer (I, J) and drain the 4WD gear box.
3. Remove (11) bolts (H), bolt (AK), and bolt (AH) from 4WD cover.
4. Remove 4WD cover (A).

NOTE: To avoid damage, during separation, to the cover and/or the gear box, use the pry points shown in fig. 44.

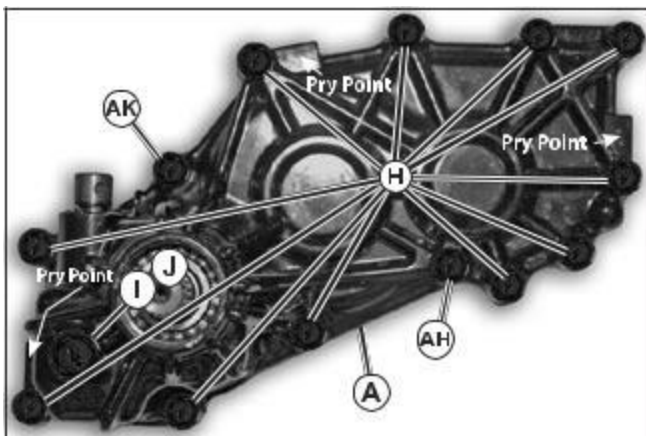

Fig. 44, 4WD Cover Removal

5. Remove the drive gear (AC) from motor shaft.

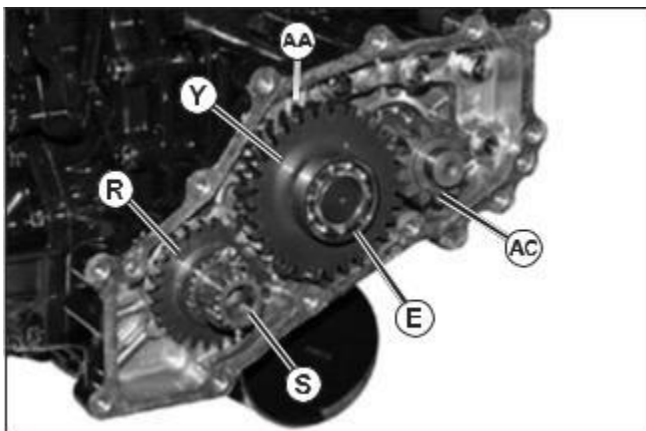

Fig. 45, 4WD Cover Removal

NOTE: Snap ring (AD) on motor shaft does not need to be removed for the 4WD gear case removal. Unless replacement is necessary. (Fig. 52).

6. Remove the first press bearing (E), gear (Y), washer (Z), and gear (AA) from 4WD reduction shaft (X). Remove 4WD reduction shaft (X), and the second press bearing (E) from the 4WD gear box as a single item. (Fig. 46)
7. Remove press bearing (E) from 4WD reduction shaft (X).

NOTE: When reinstalling, take care to place gears in their original order; with the thicker gear in front (with raised surface towards the bearing) and the thinner gear behind.

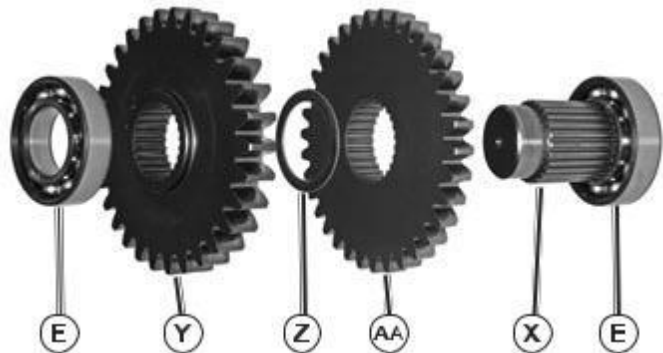

Fig. 46, 4WD Cover Removal

8. Remove snap rings (V) and (AM); then, gear (R) from shaft (S). Remove snap ring (AN) and remove (S, T, U, V, W, and AO) as a single item from the 4WD gear case.
9. Remove press bearing (AO), collar (W), snap ring (V), press bearing (U), and collar (T) from shaft (S). (Fig. 47)

NOTE: Flat end of shift collar goes toward bearing.

10. Clean bearings in a suitable solvent. Dry with com-pressed air.

IMPORTANT: Avoid damage! DO NOT spin bearing using compressed air. Damage to bearing balls, cage, and races could result.

11. Inspect bearings for discolored, burned, balls and/or races. Check balls and races for spalling or cracking. Roll bearing by hand to check for rough turning or excessive looseness or play between balls and races. Replace bear-ings as required.

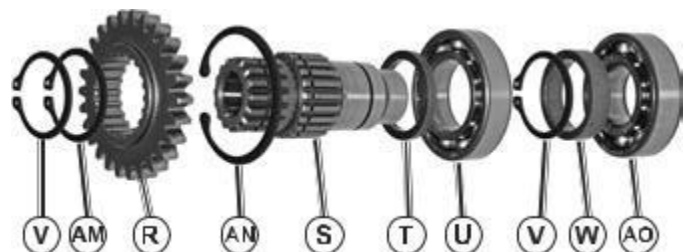

Fig. 47, 4WD Cover Removal

Tuff Torq K92 Hydrostatic Transaxle

12. Remove bolt (F) and keeper plate (AP) from the 4WD cover.
13. Use drift to drive out spring pin (L) and roll pin (M) securing 4WD shift arm (C) to 4WD shift shaft (G); then, remove 4WD shift arm from the 4WD shift shaft. Replace if damaged or worn.

NOTE: Replace O-ring (K, see fig. 52) on 4WD shift shaft when reinstalling.

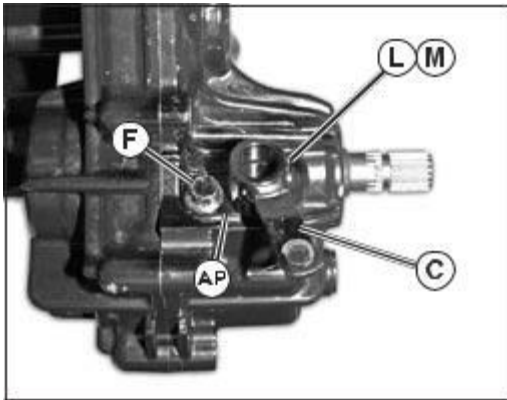

Fig. 48, 4WD Cover Removal

14. Slide the 4WD shift shaft (G) down into the cover until bearing shift block (P) is clear of the front shift collar (Q). Remove the bearing shift block; then, pull out the front shift collar (Q) and 4WD output shaft (N). Drive out roll pin (M) from 4WD shift arm (O) by aligning roll pin with open port in 4WD cover (bolt (I) must be removed). Replace if damaged or worn. (Fig. 49)
15. Remove 4WD shift arm from 4WD shift shaft by pulling shaft up from the 4WD cover.

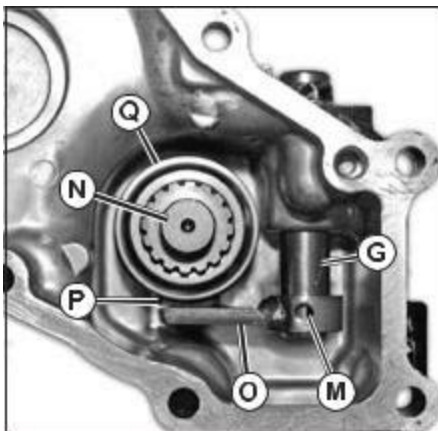

Fig. 49, 4WD Cover Removal

16. Remove the bearing (E) from the 4WD output shaft (N).
17. Carefully remove front shift collar (Q) from 4WD output shaft. As separation occurs the detent balls (AR) and spring (AQ) will become visible. (Fig. 50)

CAUTION: Detent Balls are under pressure from spring while assembled. Care should be taken during disassembly to in-sure that they do not fly out, possibly causing damage and/or injury. Safety glasses should be worn at all times while working on the transaxle.

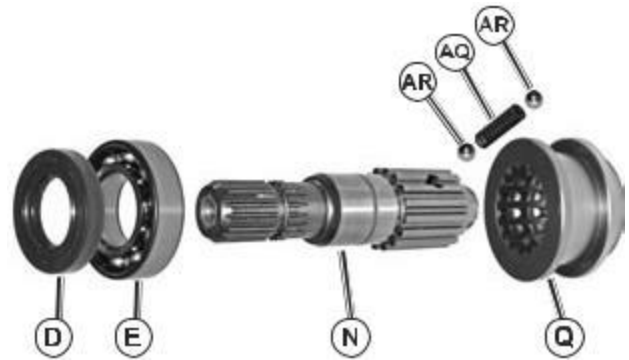

Fig. 50, 4WD Cover Removal

18. From the 4WD gear case (B), remove (2) bolts with wash-ers (AG and AI). Remove (2) bolts (H) and (1) bolt with washer (AL and AI). (Fig. 51)
19. Remove 4WD gear case from motor case assembly.

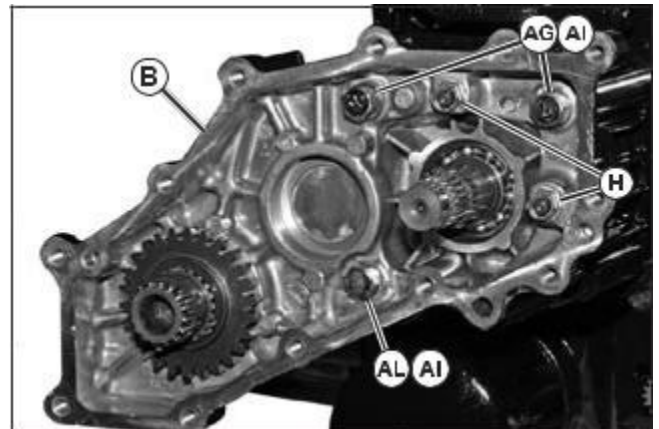

Fig. 51, 4WD Cover Removal

20. Measure OD of bearing surface. If not within specifications, replace front wheel drive output shaft.

NOTE: Replace seal (D) if output shaft is removed. (Fig. 50).

4WD Output Disassembly and Assembly (continued)

21. Measure ID of pilot hole. If not within specifications, replace 4WD output shaft.
22. Inspect sleeve on 4WD output shaft (N) for wear. Re-place, as necessary.
23. Inspect splines on 4WD output shaft (N) and shift collar (Q) for damage. Replace as required. (Fig. 52)
24. Inspect groove in shift collar (Q) for scoring or damage. Replace as required.

Specifications for 4WD Output Shaft:

- OD at Bearing 24.98 - 25.0 mm (0.983 - 0.984 in.)
 - ID Pilot Hole 17.0 - 17.02 mm (0.669 - 0.670 in.)
25. Measure shaft bore in 4WD cover. If not in specifications, replace housing.
 26. Measure OD of shaft in bearing area. If not in specifications, replace shaft.

Specifications:

- Shaft OD 16.93 - 17 mm (0.667 - 0.669 in.)
- 4WD Cover Shaft Bore ID 17 - 17.043 mm (0.669 - 0.671 in.)

Assembly and Installation:

Assembly and installation of the 4WD output assembly is carried out in reverse order of disassembly and removal.

Replace the gasket (AE, see fig. 52), and gasket (AF, only if 4WD gear case was removed) or use a thin bead of silicone sealant between motor case assembly and 4WD gear case. Also, between 4WD gear case and 4WD cover.

Refill transaxle w/approximately 7.8L (8.2 qt) for 4WD and 9.0L (9.5 qt) for 4WD w/rear PTO. Use ATF Type F and fill to crosshatched area of dipstick.

Tighten cap screws to specification.

Torque Specification:

- Cap Screws. 16 - 22 N•m (144 - 192 lb-in.)

4WD Output Disassembly

- A - 4WD Front Cover
- B - 4WD Gear Case
- C - Shift Arm 4WD
- D - Seal
- E - Bearing
- F - Bolt
- G - Shaft Shift 4WD
- H - Bolt
- I - Bolt (12 mm)
- J - Gasket
- K - O-ring
- L - Spring Pin
- M - Spring Pin
- N - Shaft Front Drive
- O - Arm Shift 4WD
- P - Block Shift Bearing
- Q - Collar Front Shift
- R - Gear 4WD
- S - Shaft 4WD
- T - Collar

Tuff Torq K92 Hydrostatic Transaxle

4WD Output Disassembly (continued)

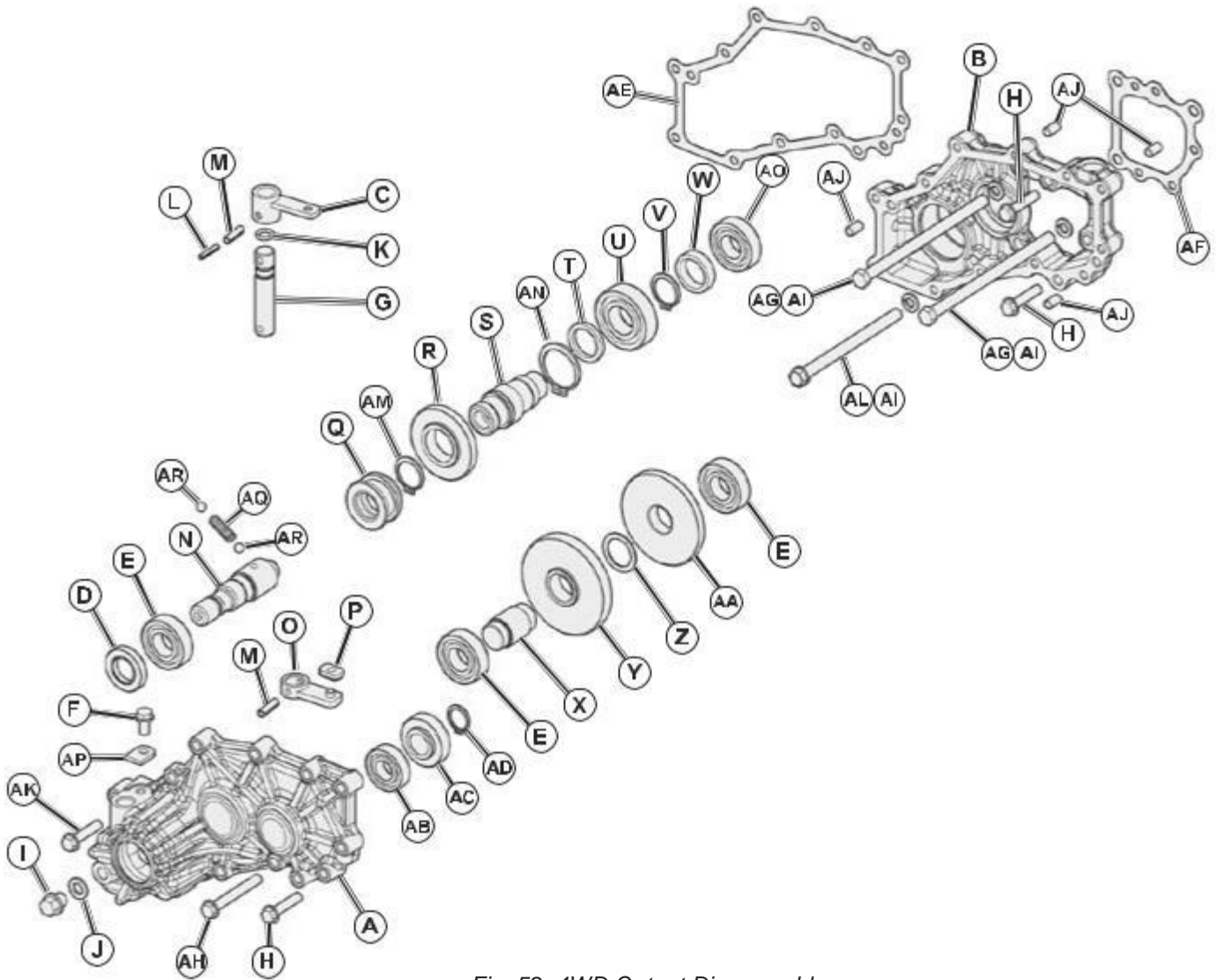

Fig. 52, 4WD Output Disassembly

- | | |
|--------------------------------|-------------------|
| U - Bearing | AG - Bolt |
| V - Snap Ring | AH - Bolt |
| W - Collar | AI - Washer |
| X - Shaft Reduction 4WD | AJ - Guide Pin |
| Y - Gear 4WD | AK - Bolt |
| Z - Washer | AL - Bolt |
| AA - Gear | AM - Ring |
| AB - Bearing | AN - Ring |
| AC - Gear | AO - Bearing |
| AD - Ring | AP - Keeper Plate |
| AE - 4WD Gear Box Gasket | AQ - Spring |
| AF - 4WD Gear Box Cover Gasket | AR - Detent Ball |

Hydrostatic Transmission 2WD and 4WD

Hydrostatic Transmission Removal:

1. Remove charge pump. (See “Charge Pump Removal and Installation” on page 2)

IMPORTANT: Avoid damage! Do not drop or damage pump valve plate when removing center valve block assembly. Do not nick or scratch lapped or machined surfaces of the valve plates or cylinder block components. The slightest damage can cause poor performance.

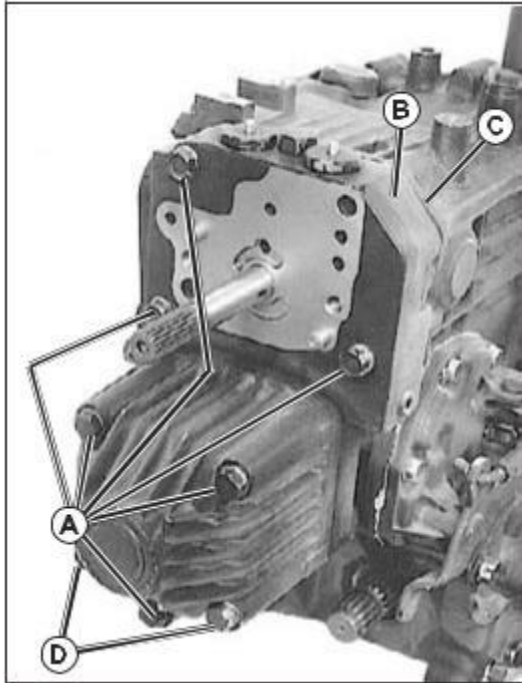

Fig. 53, 2WD Shown (4WD similar)

2. Remove cap screws (A) — leaving in place 2 cap screws (D). Carefully remove center valve block (B) and motor assembly from transaxle.
3. Replace gasket (C) if torn or damaged.

Hydrostatic Transmission Motor Removal:

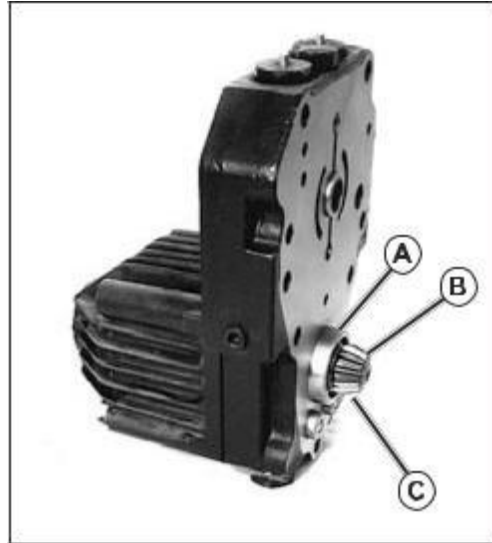

Fig. 54, 2WD Shown (4WD similar)

2WD Shown

1. Remove retaining ring (B), bevel input pinion (C), and ball bearing (A).
2. Inspect bearing for smooth rotation.

NOTE: Bevel input pinion and bevel input gear must be re-placed as a set.

3. Check pinion for wear or damage.
4. Replace retaining ring if ring is distorted during removal.

Tuff Torq K92 Hydrostatic Transaxle

Hydrostatic Transmission Motor Disassembly and Assembly (2WD)

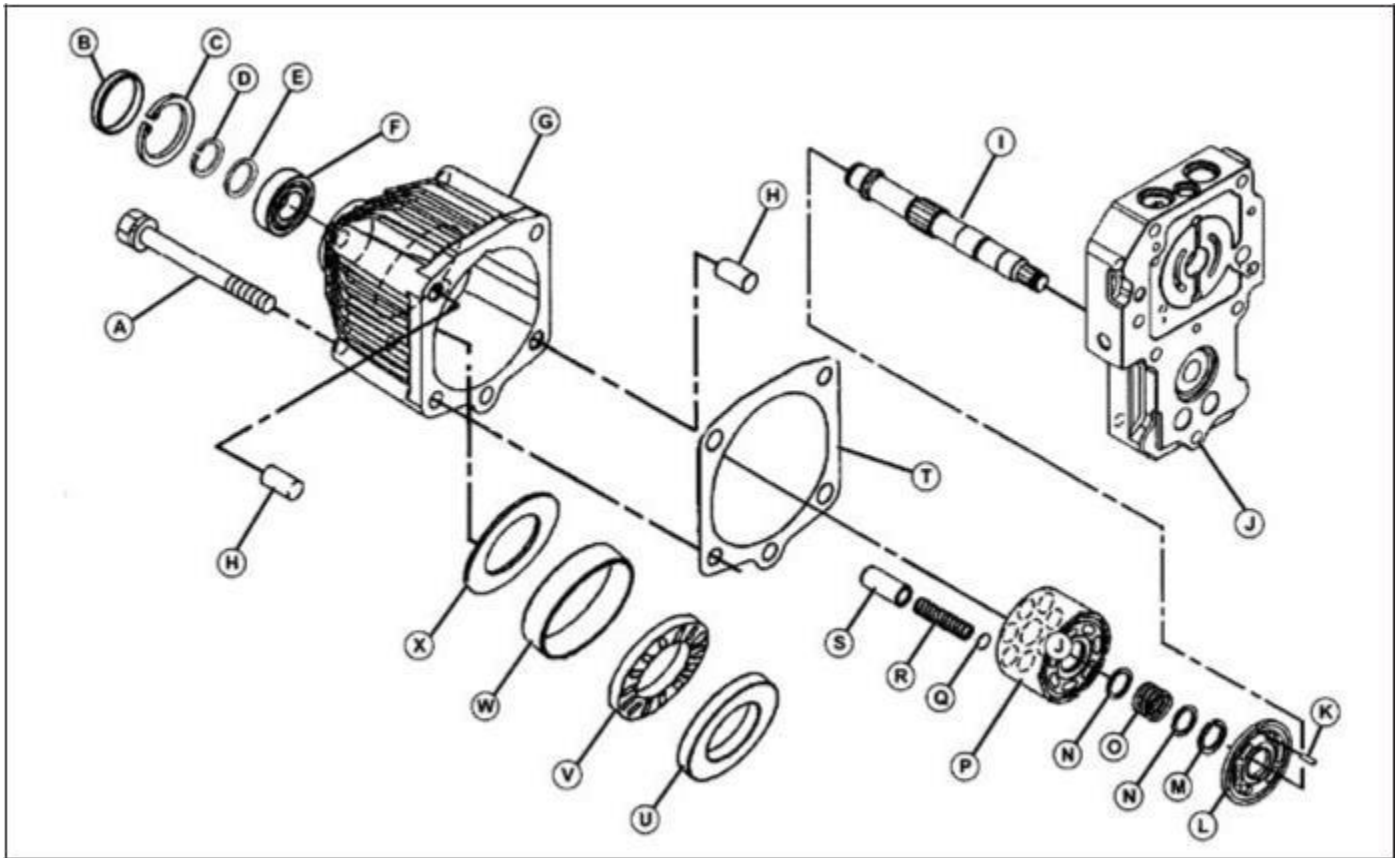

Fig. 55, Hydrostatic Transmission Motor Disassembly (2WD)

- A - Cap Screw (2 pieces)
- B - Seal Cap
- C - Snap Ring
- D - Snap Ring
- E - Washer
- F - Ball Bearing
- G - Motor Case
- H - Locating Sleeve (2 used)
- I - Motor Shaft
- J - Center Valve Block Assembly
- K - Locating Pin
- L - Motor Valve Plate
- M - Snap Ring
- N - Washer
- O - Spring
- P - Cylinder Block
- Q - Shim
- R - Piston Spring

- S - Piston
- T - Gasket
- U - Thick Thrust Plate
- V - Thrust Bearing
- W - Bushing
- X - Thin Thrust Plate

IMPORTANT: Avoid damage! Do not drop or damage motor valve plate when removing motor assembly. Do not nick or scratch lapped or machined surfaces of the valve plate or cylinder block components. The slightest damage can cause poor performance.

1. Remove two cap screws (A). (Fig. 55)

IMPORTANT: Avoid damage! Keep pistons (S) matched with bore of cylinder block (P). Do not interchange motor pistons and valve plate (L) with pump pistons and valve plate. Pistons and cylinder blocks are a matched set.

2. Remove cylinder block assembly.

NOTE: Motor rotating components must be replaced as a set.

Hydrostatic Transmission Motor Disassembly and Assembly (2WD) (continued)

3. Inspect rotating components:

NOTE: Scoring is fine scratches or grooves cut into the highly machined surface. When the scratches can be detected by feel using a lead pencil or fingernail, the part must be replaced.

4. Check valve plate and cylinder block for grooves, scoring, discoloration or pitting.
5. Check for free movement of pistons in cylinder bore.
6. Check pistons for flat areas, scoring or discoloration.
7. Thrust bearing (V) must rotate freely. (Fig. 55)

NOTE: Thin thrust plate (X), bushing (W) and motor case (G) must be replaced as a set. (Fig. 55)

8. Inspect thin thrust washer for wear or damage. Replace as necessary.

IMPORTANT: Avoid damage! Do not damage ball bearing (F) when removing seal cap (B).

9. Remove seal cap (B) and snap ring (C) to remove shaft assembly components.
10. Inspect bushing (W), thrust bearing (V) and shaft (I) for wear or damage. Replace if necessary. (Fig. 55)

NOTE: Apply silicon sealant to outer edge of new seal cap. Install seal cap until cap is approximately 4 mm (5/32 in.) below surface of motor case.

11. Assemble parts in reverse order of removal.

NOTE: Use petroleum jelly to hold valve plate in position.

• Put motor valve plate (L) on center valve block. Make sure bronze surface is away from valve block and notch in valve plate fits on locating pin of valve block.

IMPORTANT: Avoid damage! Apply clean hydraulic oil to all mating surfaces.

IMPORTANT: Avoid damage! Pump and motor valve plates are not interchangeable. The pump valve plate has two lead-in grooves into two of the slotted ports. The motor valve plate (L) has no leading grooves.

NOTE: Motor case will seem springy because the springs in-side the cylinder block are being compressed.

Tuff Torq K92 Hydrostatic Transaxle

Hydrostatic Transmission Motor Disassembly and Assembly (4WD)

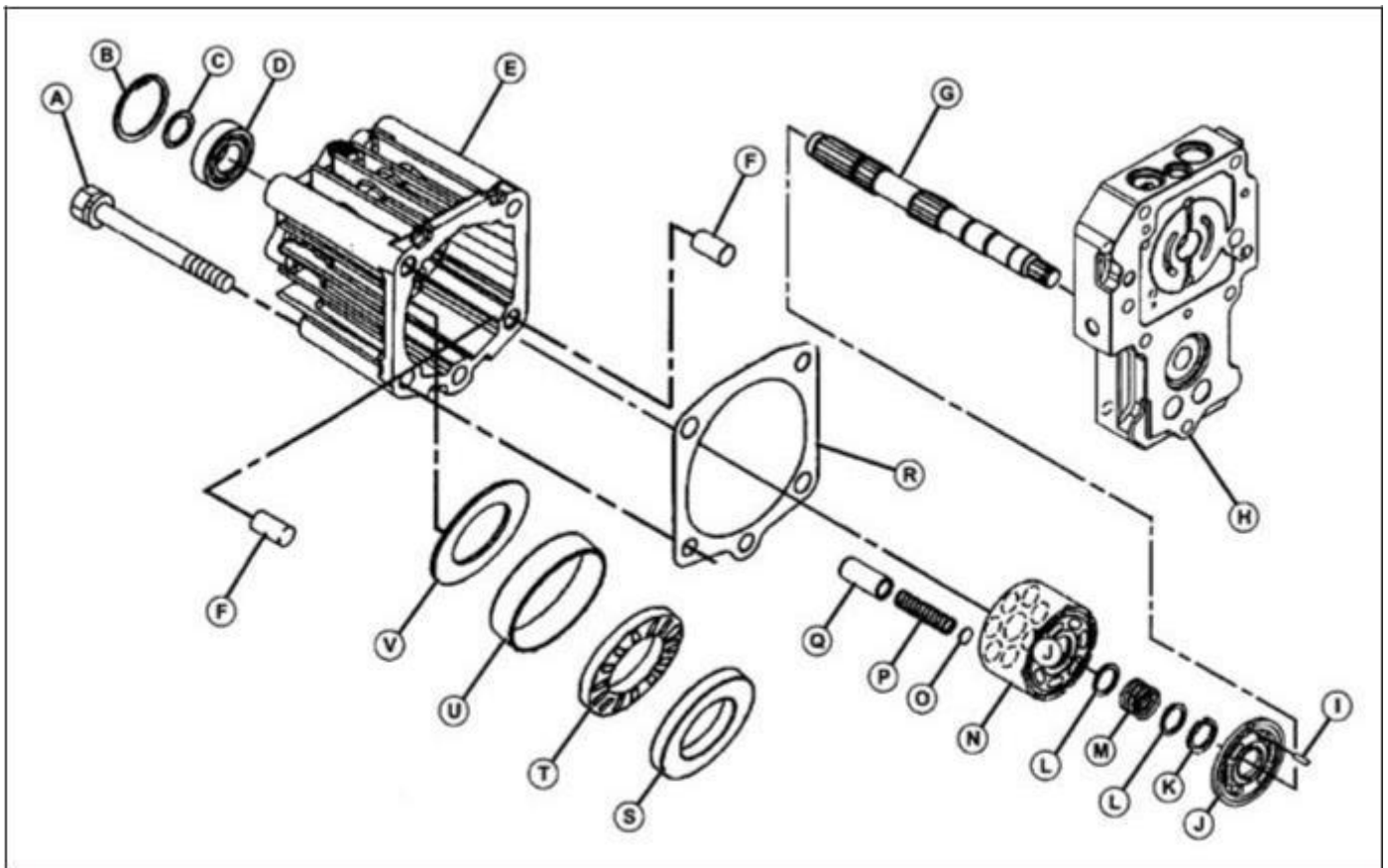

Fig. 56, Hydrostatic Transmission Motor Disassembly (4WD)

- A - Cap Screw (2 pieces)
- B - Snap Ring
- C - Snap Ring
- D - Ball Bearing
- E - Motor Case
- F - Locating Sleeve (2 used)
- G - Motor Shaft
- H - Center Valve Block Assembly
- I - Locating Pin
- J - Motor Valve Plate
- K - Snap Ring
- L - Washer
- M - Spring
- N - Cylinder Block
- O - Shim
- P - Piston Spring
- Q - Piston

- R - Gasket
- S - Thick Thrust Plate
- T - Thrust Bearing
- U - Bushing
- V - Thin Thrust Plate

1. Remove 4WD gear box assembly. (See "4WD Output Disassembly and Assembly" on page 24.)

IMPORTANT: Avoid damage! Do not drop or damage mo-tor valve plate when removing motor assembly. Do not nick or scratch lapped or machined surfaces of the valve plate or cylinder block components. The slightest damage can cause poor performance.

2. Remove two cap screws (A). (Fig. 56)

IMPORTANT: Avoid damage! Keep pistons (Q) matched with bore of cylinder block (N). Do not interchange motor pistons and valve plate (J) with pump pistons and valve plate. Pistons and cylinder blocks are a matched set.

3. Remove cylinder block assembly.

NOTE: Motor rotating components must be replaced as a set.

Hydrostatic Transmission Motor Disassembly and Assembly (4WD) (continued)

4. Inspect rotating components:

NOTE: Scoring is fine scratches or grooves cut into the highly machined surface. When the scratches can be detected by feel using a lead pencil or fingernail, the part must be replaced.

5. Check valve plate and cylinder block for grooves, scoring, discoloration or pitting.
6. Check for free movement of pistons in cylinder bore.
7. Check pistons for flat areas, scoring or discoloration.
8. Thrust bearing (T) must rotate freely. (Fig. 56)

NOTE: Thin thrust plate (V), bushing (U) and motor case (E) must be replaced as a set. (Fig. 56)

9. Inspect thin thrust plate (V) for wear or damage. Re-place as necessary.

IMPORTANT: Avoid damage! Do not damage ball bearing (D) when removing snap ring (B).

10. Remove snap ring (B) to remove shaft assembly components.

11. Inspect bushing (U), thrust bearing (T) and shaft (G) for wear or damage. Replace if necessary. (Fig. 56)

IMPORTANT: Avoid damage! Apply clean hydraulic oil to all mating surfaces.

12. Assemble parts in reverse order of removal.

NOTE: Use petroleum jelly to hold valve plate in position.

- Put motor valve plate (J) on center valve block. Make sure bronze surface is away from valve block and notch in valve plate fits on locating pin of valve block.

IMPORTANT: Avoid damage! Pump and motor valve plates are not interchangeable. The pump valve plate has two lead-in grooves into two of the slotted ports. The motor valve plate (J) has no leading grooves.

NOTE: Motor case will seem springy because the springs inside the cylinder block are being compressed.

Tuff Torq K92 Hydrostatic Transaxle

Center Valve Block Disassembly and Assembly

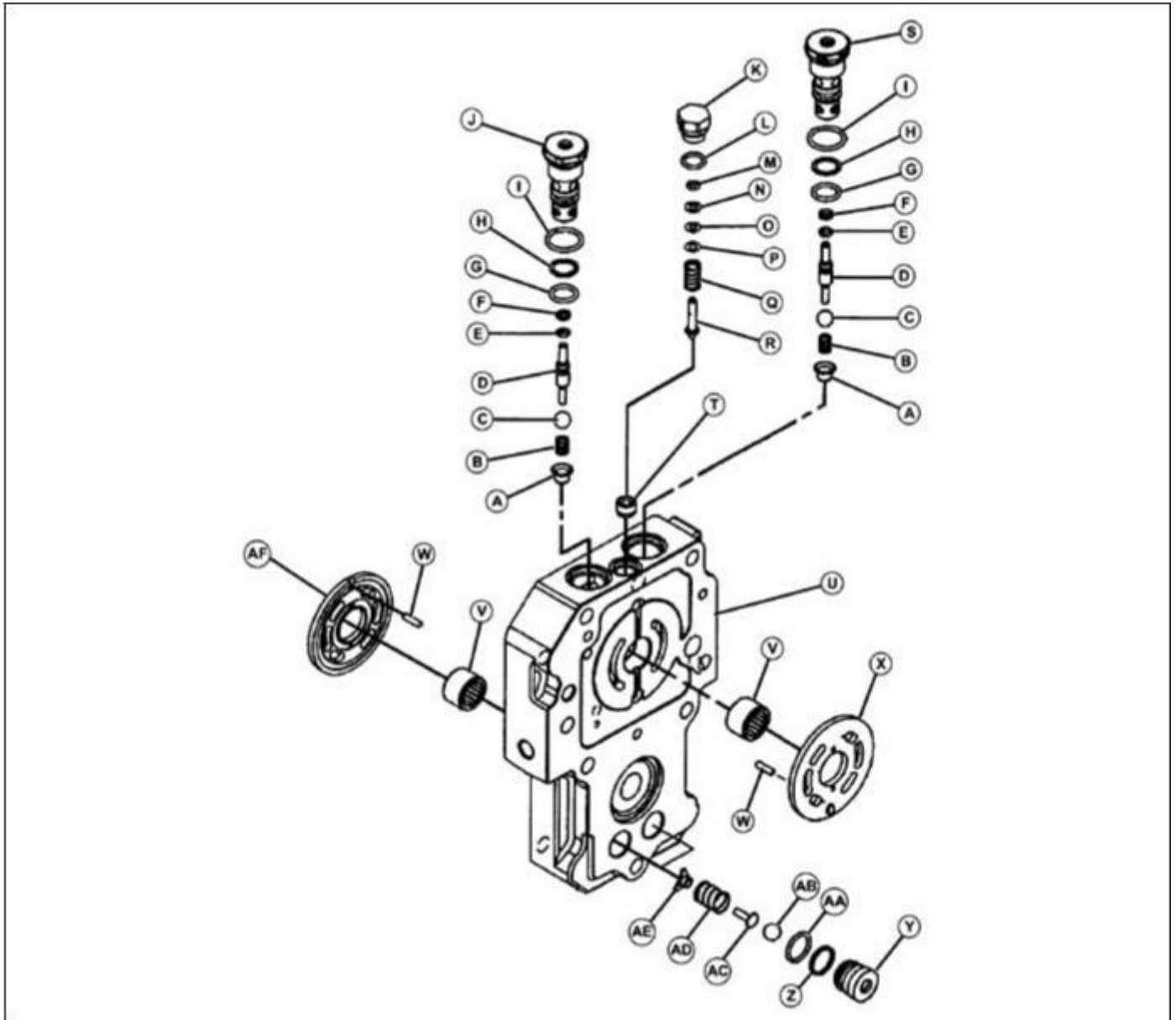

Fig. 57, Center Valve Block Disassembly

- | | |
|-------------------------|--|
| A - Holder | K - Top Plug |
| B - Spring | L - O-ring |
| C - Ball | M - O-ring |
| D - Push Pin | N - Washer |
| E - O-ring | O - Shim (0.5) |
| F - Seal | P - Shim (0.2) |
| G - O-ring | Q - Spring |
| H - Back-up Ring | R - Charge Pressure Relief Valve Plunger |
| I - O-ring | S - Reverse Check Valve |
| J - Forward Check Valve | T - Seat |

Center Valve Block Disassembly and Assembly (continued)

U - Center Valve Block

V - Needle Bearing (2 used)

W- Locating Pin (2 used)

X - Pump Valve Plate

Y - Anti-Cavitation Valve Body

Z - Backup Ring

AA- O-ring

AB- Ball

AC- Ball Holder

AD- Spring

AE- Retainer

AF- Motor Valve Plate

NOTE: Remove motor assembly if necessary to inspect needle bearing. (See "Hydrostatic Transmission Motor Removal:" on page 28.)

1. Remove and inspect directional check valves.

IMPORTANT: Avoid damage! The reverse check valve must be installed in the left port. The check valve can be identified by a small orifice drilled into a land between the two sets of valve passageways.

2. Replace locator pins if missing or damaged.
3. Inspect needle bearings for wear or damage. If bearings are replaced, install new bearings with the stamped end away from center valve block.
4. Push bearings into bore until end of bearing is approximately 3 mm (7/64 in.) above the surface of the valve block.
5. Inspect anti-cavitation valve assemblies.

NOTE: Screens may be located in bores of transaxle case.

6. Check suction screens for blockage.
7. Carefully pull anti-cavitation valve body from center valve block so as not to lose parts.
8. Replace parts as necessary.
9. Apply oil to O-rings and push assembly to bottom of bore.
10. Inspect center valve block where charge pump contacts block for scoring.
11. Replace center valve block if necessary.

NOTE: Scoring is fine scratches or grooves cut into the highly machined surface. When the scratches can be detected by feel using a lead pencil or fingernail, the part must be replaced.

12. Inspect valve plate for grooves, scoring, discoloration or pitting.

IMPORTANT: Avoid damage! Pump and motor valve plates are not interchangeable. The pump valve plate has two lead-in grooves into two of the slotted ports. The motor valve plate has no leading grooves.

13. Put pump valve plate on center valve block. Make sure bronze surface is away from valve block and notch in valve plate fits on locating pin of valve block.

NOTE: Use petroleum jelly to hold valve plate in position.

14. Remove plug to inspect charge pressure relief valve parts.
15. Check plunger for nicks, wear or damage.
16. Inspect plunger seat in center valve block. Remove any obstructions and replace center valve block if seat is worn or damaged.

Hydrostatic Transmission Motor Installation

NOTE: Replace retaining ring (D) if ring is distorted during removal.

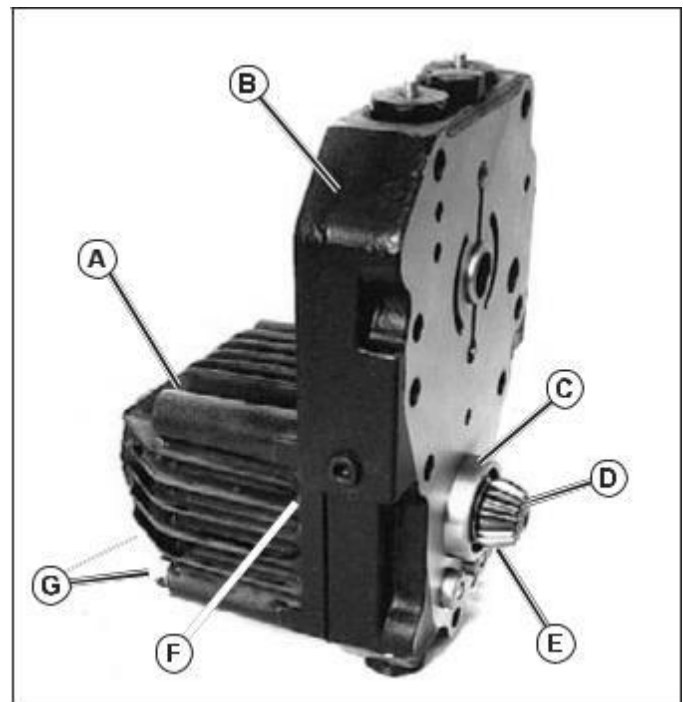

Fig. 58, Hydrostatic (2WD) Motor

1. Secure motor housing assembly (A) and gasket (F) to center valve block (B) with (2) lower cap screws (G). Install ball bearing (C) and bevel input pinion (E) — secure with retaining ring (D).

Hydrostatic Transmission Installation

IMPORTANT: Avoid damage! Do not drop or damage pump valve plate when removing center valve block assembly. Do not nick or scratch lapped or machined surfaces of the valve plates or cylinder block components. The slightest damage can cause poor performance.

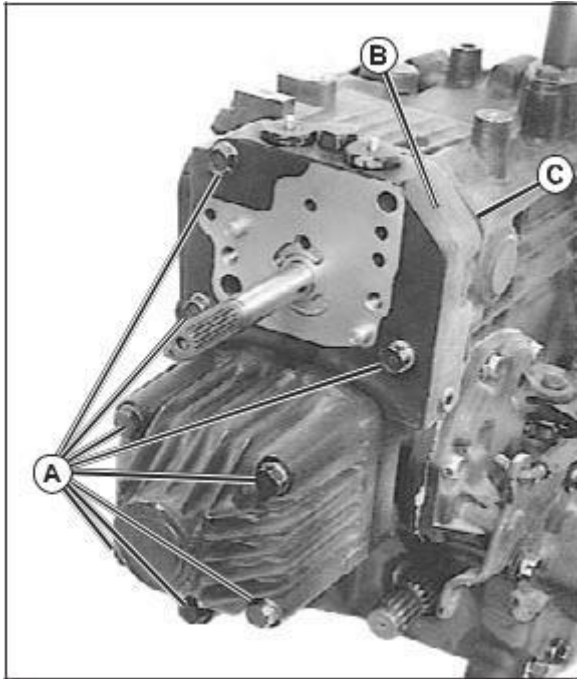

Fig. 59, Hydrostatic, 2WD (4WD similar) Motor Install

1. Install gasket (C). (Fig. 59)
2. Install center valve block (B) and motor assembly to transaxle housing and secure with cap screws (A). (Fig. 59)
 - Tighten cap screws (A) to 39 N•m (29 lb-ft).
3. Install charge pump. (See “Charge Pump Removal and Installation” on page 2)

Hydrostatic Pump Inspection

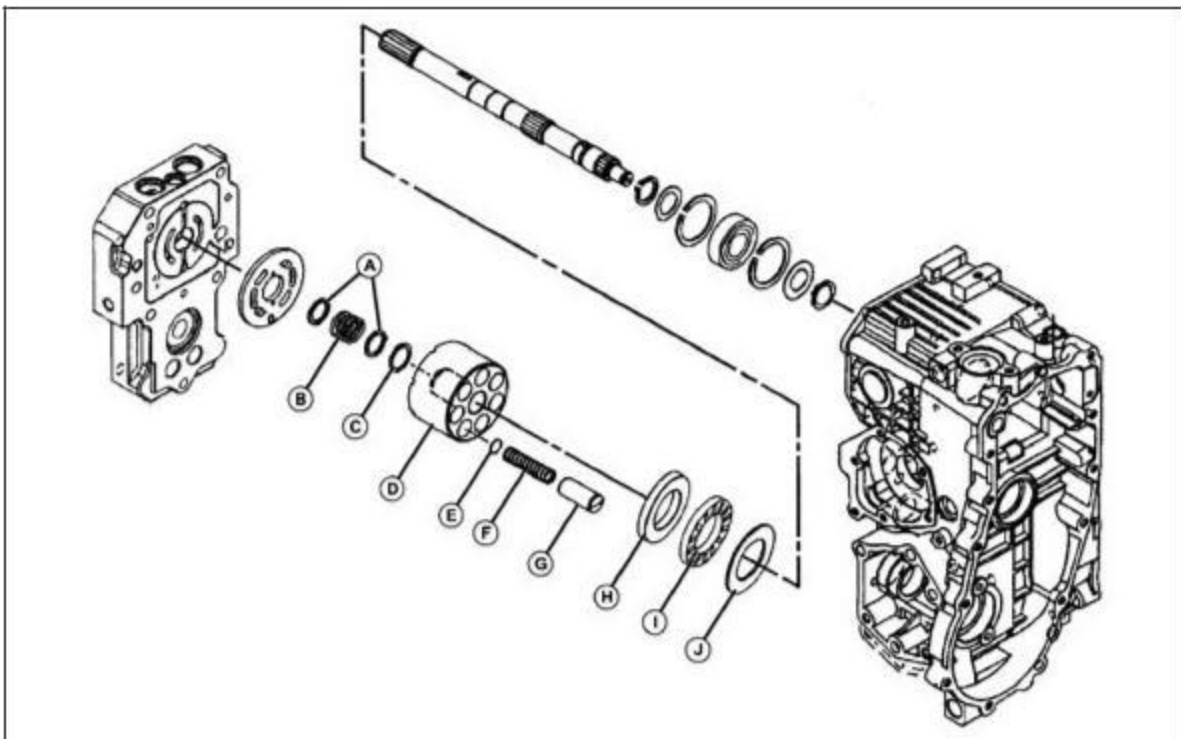

Fig. 60, Hydrostatic Pump Disassembly

Hydrostatic Pump Inspection (continued)

A - Washers

B - Piston Spring (7 used)

C - Snap Ring

D - Cylinder Block

E - Washer

F - Spring

G - Piston (7 used)

H - Thick Thrust Plate

I - Thrust Bearing

J - Thin Thrust Plate

IMPORTANT: Avoid damage! Keep pistons matched with bore of cylinder block. Do not interchange motor pistons and valve plate with pump pistons and valve plate. Pistons and cylinder blocks are a matched set.

1. Spring is compressed. Apply an external force to compress spring farther before removing snap ring. Then slowly remove external force.
2. Remove parts from transaxle as necessary.

NOTE: Pump rotating components must be replaced as a set. Thin thrust plate must be replaced as a set with the pump swash plate and bushing.

3. Check cylinder block for grooves, scoring, discoloration or pitting.

NOTE: Scoring is fine scratches or grooves cut into the highly machined surface. When the scratches can be detected by feel using a lead pencil or fingernail, the part must be replaced.

4. Check for free movement of pistons in cylinder bores.
5. Check pistons for flat areas, scoring or discoloration. Thrust bearing must rotate freely.

For inspection of pump valve plate, refer to "Center Valve Block Disassembly and Assembly:" on page 33.

Transaxle Disassembly

1. Remove control arm damper. (See "Control Arm and Damper Removal and Installation" on page 1.)
2. Remove hydrostatic transmission and pump. (See "Hydrostatic Transmission 2WD and 4WD" on page 35.)
3. Remove axle housings. (See "Rear Axle Assembly Removal and Installation" on page 41, and See "Rear Axle Assembly - Disassembly and Assembly" on page 42.)
4. Remove brakes. (See "Brakes Removal and Installation" page 43.)

5. Remove PTO idler shaft assembly (C), snap ring (E), PTO gear (D) (or rear drive gear set).

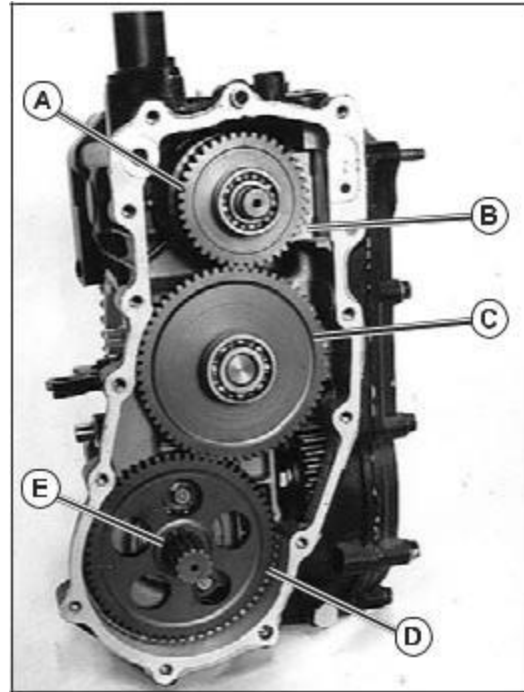

Fig. 61, Without Rear PTO Option

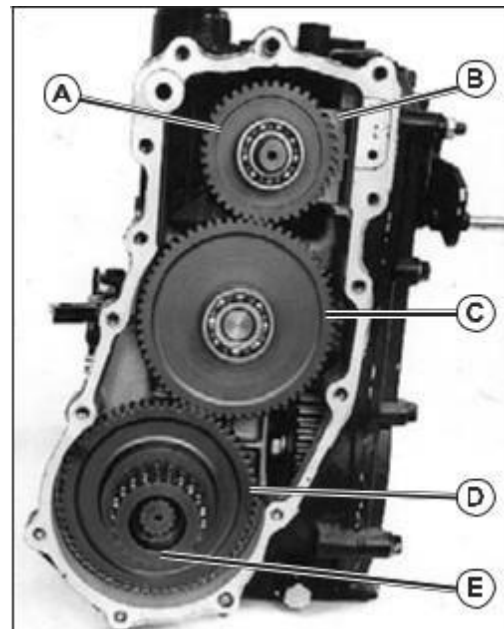

Fig. 62, With Rear PTO Option

6. Remove PTO brake shoe (B) and clutch (A). (See "PTO Brake Removal and Installation" on page 6.)
7. Remove large snap ring (H) and input shaft assembly.
8. Remove large snap ring (L), small snap rings (G and K) washers (M and J), and ball bearing (I) from input shaft (F). (Fig. 63)

Tuff Torq K92 Hydrostatic Transaxle

Transaxle Disassembly (continued)

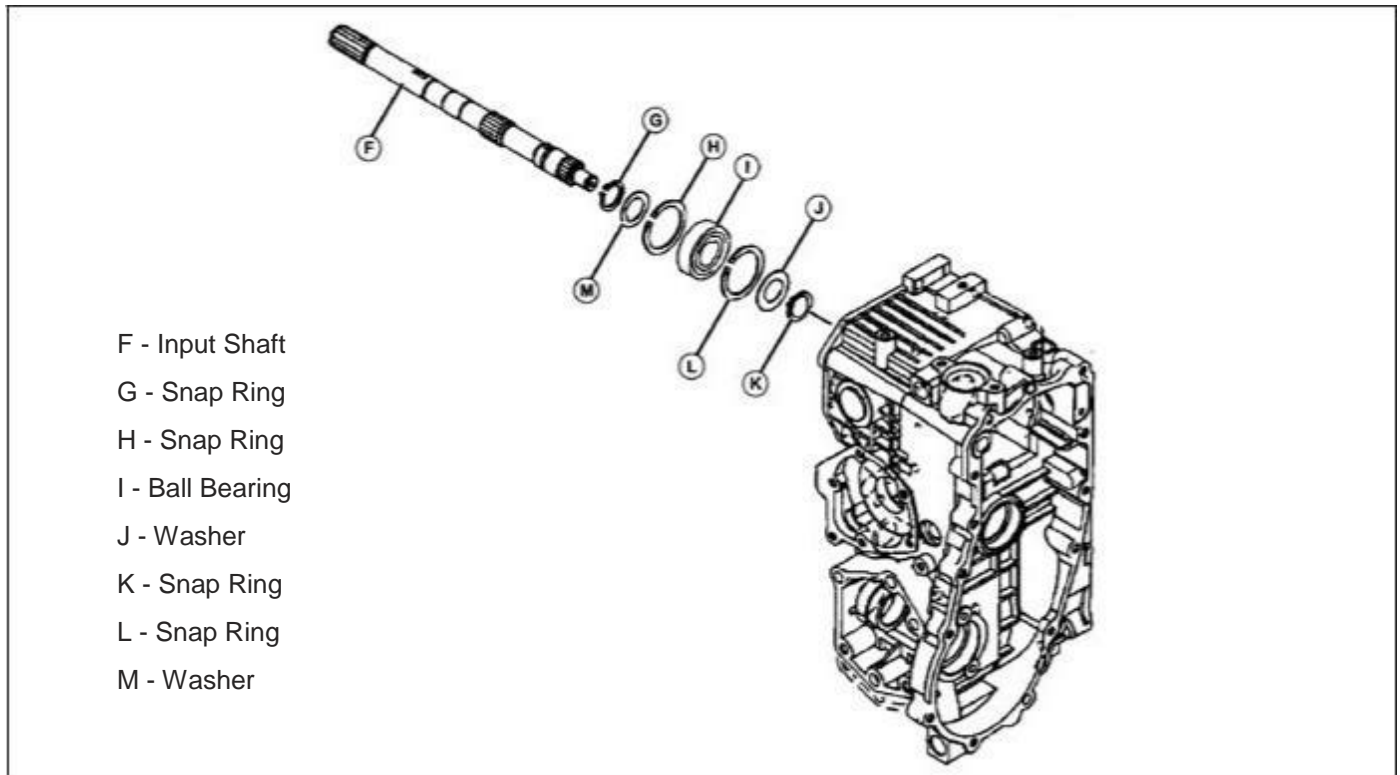

Fig. 63, Transaxle Input Shaft Disassembly

9. Lay transaxle on left side and remove sixteen (16) cap screws (N) attaching right cover assembly (O).



Fig. 64, Right Transaxle Cover

10. Remove final pinion shaft ball bearing. Bearing may remain in cover assembly.

IMPORTANT: Avoid damage! Bearing, washer and differential pinion located on top of differential assembly are loose. Do not drop or lose parts.

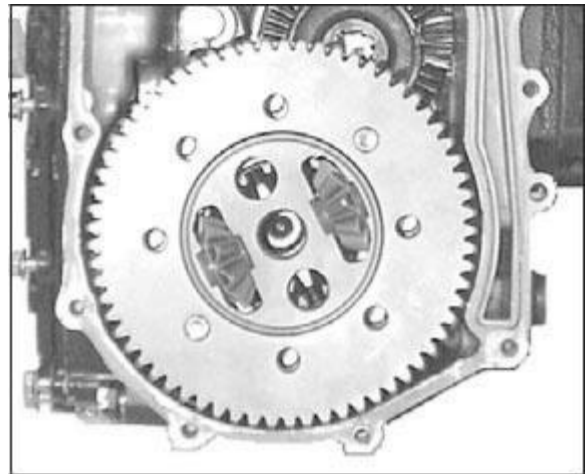

Fig. 65, Final Pinon Gear

11. Lift final gear and differential assembly and differential lock shaft from transaxle case together as an assembly.
12. Remove final pinion shaft assembly. (Fig. 65)

Transaxle (Right Cover) Disassembly and Assembly

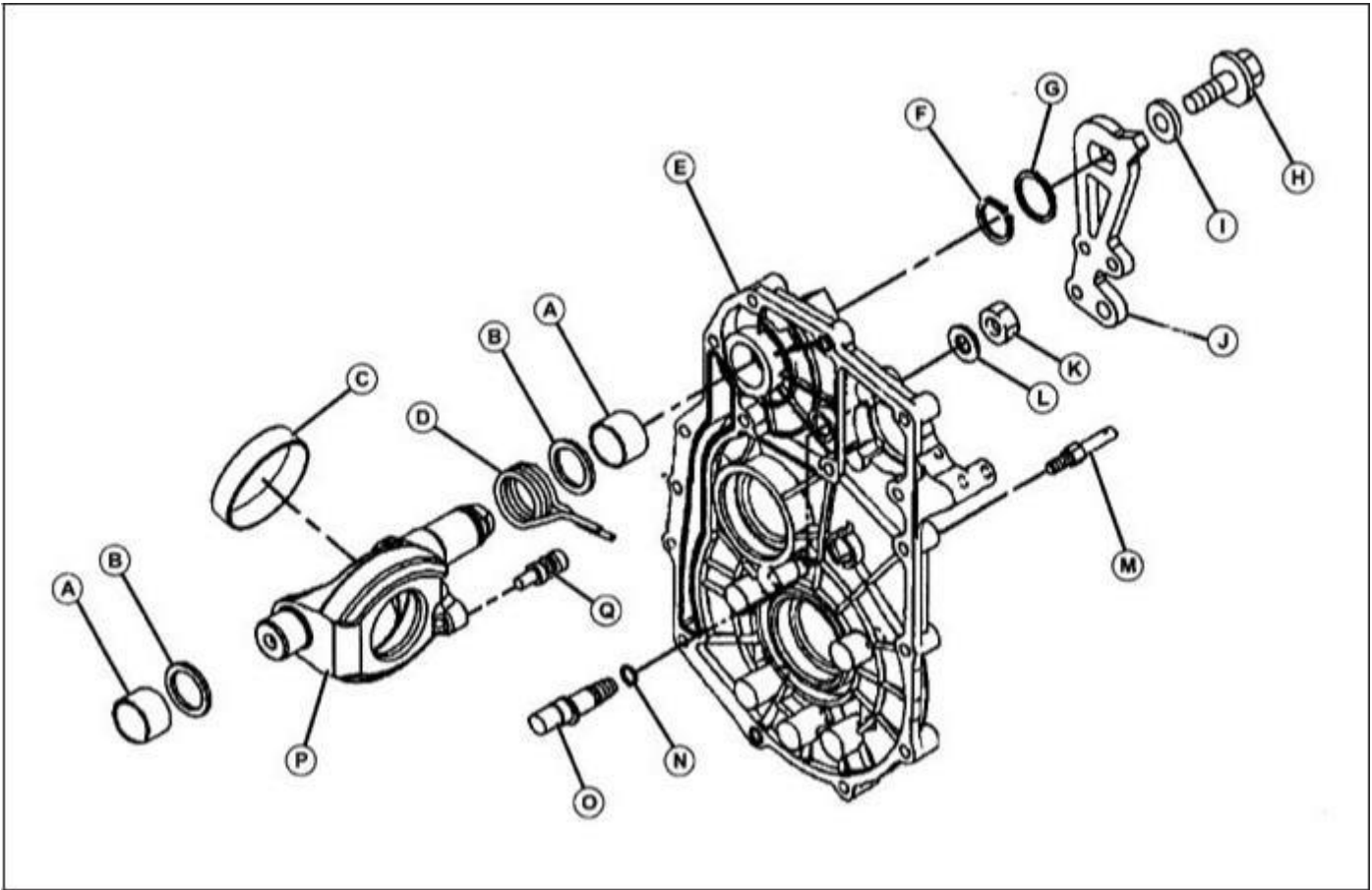

Fig. 66, Transaxle (Right Cover) Disassembly

A - Swash Plate Bearing

B - Washer

C - Bushing

D - Spring

E - Cover

F - Snap Ring

G - Washer

H - Cap Screw

I - Washer

J - Control Arm

K - Nut

L - Washer

M - Pivot Stud

N - O-ring

O - Eccentric Adjust Fulcrum

P - Swash Plate

Q - Fulcrum Cap Screw

1. Remove nut (H), washer (I), and snap ring (F). (Fig. 66)
2. Pull swash plate from cover (E).

NOTE: Pump swash plate, bushing, and thin thrust plate must be replaced as a set.

3. Inspect transaxle cover components.
4. Check bushing, bearing and swash plate contact surfaces for wear or damage. Replace as necessary.
5. Inspect O-rings on swash plate and eccentric adjust fulcrum for cuts or damage.
6. Install spring so legs are crossed and each leg of spring fits into a groove of the fulcrum cap screw.
7. If swash plate bearing was removed, install new bearing until end of bearing is even with the inside surface of the cover.
8. Put petroleum jelly on all O-rings. Install swash plate assembly and remaining components.

NOTE: Use medium strength thread lock and sealer.

Tuff Torq K92 Hydrostatic Transaxle

Inspection of Transaxle Case

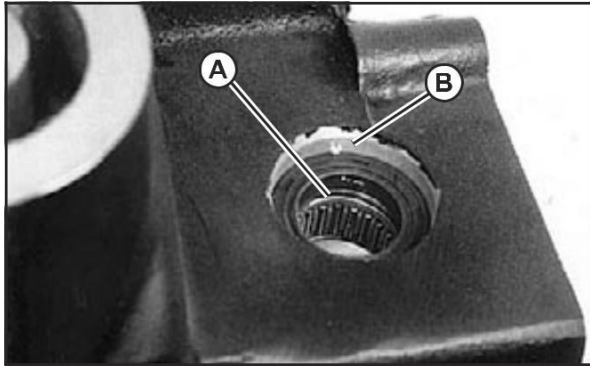

Fig. 67, Front PTO Shaft Port

1. Remove front PTO shaft seal (B). (Fig. 67)
2. Inspect needle bearing (A) for wear or damage. Remove if necessary. Install new needle bearing from inside case with bearing identification marks toward the inside of the case. Push bearing tight against shoulder in bore.
3. Install new seal with the open, spring side towards the inside of the case.
4. Push seal against shoulder in bore.

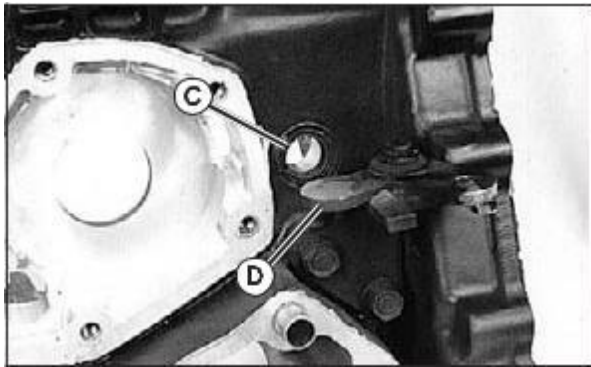

Fig. 68, Differential Shaft Port

5. Replace differential lock shaft seal (C). (Fig. 68)

NOTE: Differential lock plate (D) may have to be removed to install new seal.

6. Install new seal with the open, spring side towards inside of case. Push seal tight against bottom of bore.

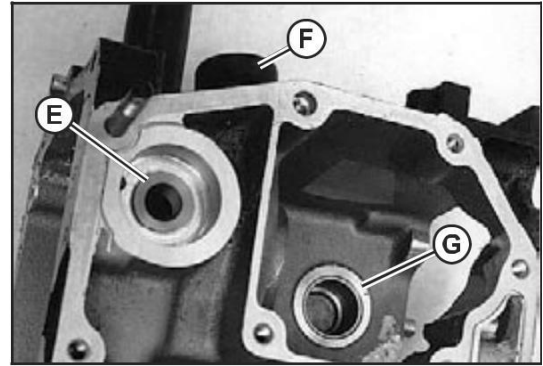

Fig. 69, PTO Brake Pin Port, Swash Plate Bearing, and Vent Cap

7. Inspect PTO brake pin sleeve (E) for scoring or damage. Replace if necessary.
8. Push sleeve out from inside of case.
9. Install new sleeve into case until flange of sleeve is tight against case.
10. Inspect swash plate bearing (G) for wear or damage. Replace if necessary.
11. Install new bearing using a disk driver. Push bearing to bottom of bore.
12. Inspect vent cap (F) for damage or obstructions. Replace as necessary.

Transaxle Assembly:

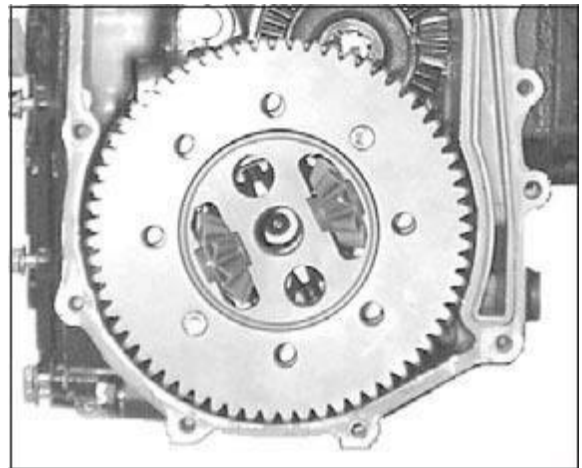

Fig. 70, Final Pinion Gear

1. Apply clean hydraulic oil to all internal components.
2. Install final pinion shaft assembly into transaxle case with bevel gear end in first.

IMPORTANT: Avoid damage! Bearing and washer on top of differential assembly are loose. Do not drop or lose parts.

3. Put fork of differential lock shaft into groove of collar on differential assembly. Install differential assembly and differential lock shaft together into transaxle case.
4. Install ball bearing.



Fig. 71, Transaxle Right Cover Assembly

5. Apply a bead of silicon sealant to mating surface of transaxle case.
6. Carefully lower right transaxle cover assembly (B) onto case while making sure bearings and shafts fit into bores properly. Make sure washer on swash plate does not fall out of position. Secure with sixteen (16) cap screws (A), and tighten to specification below. (Fig. 71)

Transaxle Case Cap Screw Torque Specifications:

- Used Transaxle Case 25 N•m (18 lb-ft)
- New Transaxle Case 30 N•m (22 lb-ft)

7. Assemble bearing, washers and snap rings on input shaft.
8. Install input shaft assembly and large snap ring.

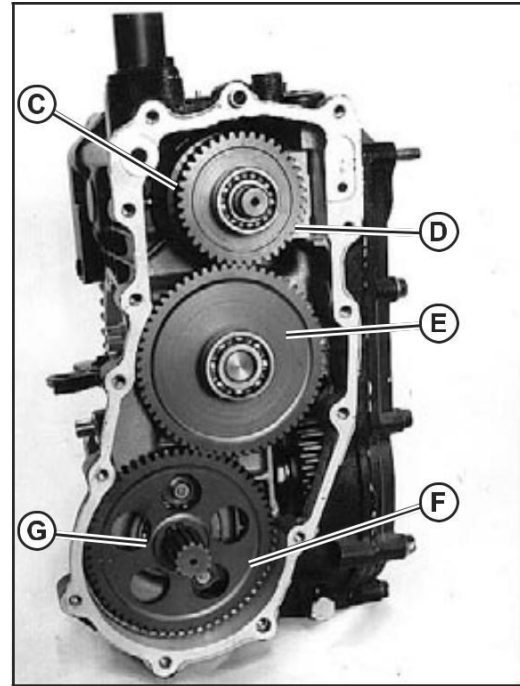

Fig. 72, Without Rear PTO Option, Assembly

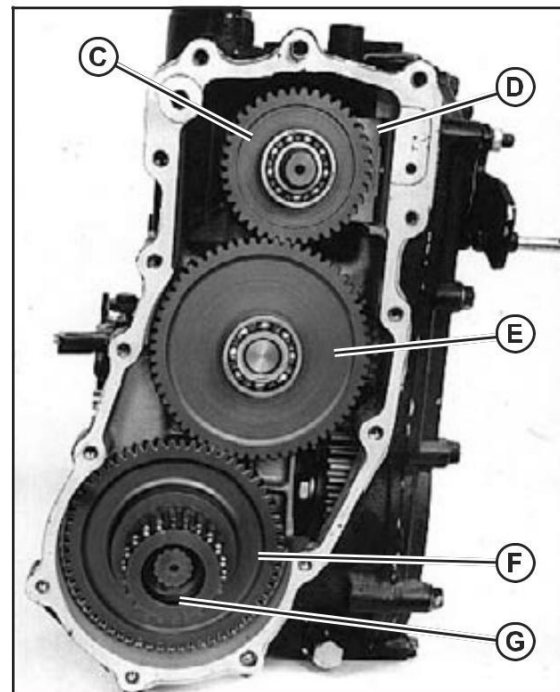

Fig. 73, With Rear PTO Option, Assembly

9. Install PTO brake shoe (D) and PTO clutch assembly (C). (See "PTO Brake Removal and Installation" on page 6.) (Fig. 72)
10. Install PTO idler shaft assembly (E), PTO gear (F) (or rear PTO gear on rear PTO option units), and snap ring (G).
11. Install PTO drive train. (See "PTO Drive Train (Mid and Rear PTO) Removal and Installation" on page 11.)
12. Install brakes. (See "Brakes Removal and Installation" on page 43.)
13. Install axle housings. (Fig. 74)
14. Install hydrostatic transmission and pump.
15. Install control arm damper. (See "Control Arm and Damper Removal and Installation" on page 1)

Rear Axle Assembly Removal and Installation

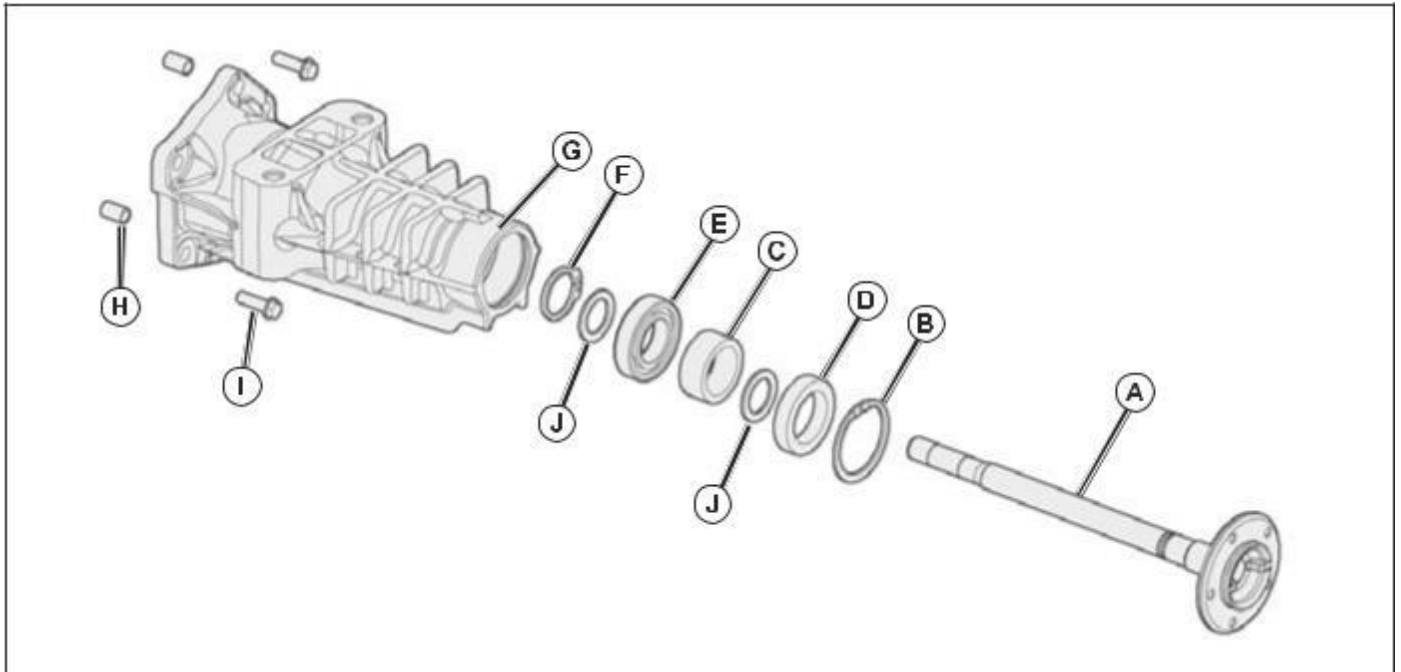

Fig. 74, Axle Disassembly

- A - Shaft
- B - Snap Ring
- C - Sleeve
- D - Seal
- E - Ball Bearing
- F - Snap Ring
- G - Axle Housing
- H - Bushing (2 used)
- I - Cap Screw (6 used)
- J - Washer

IMPORTANT: Note position of two locator bushings (J) when removing axle housing.

1. Remove six cap screws (I) holding axle housing to transaxle housing, and remove axle assembly. (Fig. 74)
2. Clean axle housing and transaxle mating surfaces. Apply a bead of silicon sealant to mating surface.
3. Repeat for other side if necessary. Installation is done in the reverse order of removal.

Rear Axle Assembly - Disassembly and Assembly

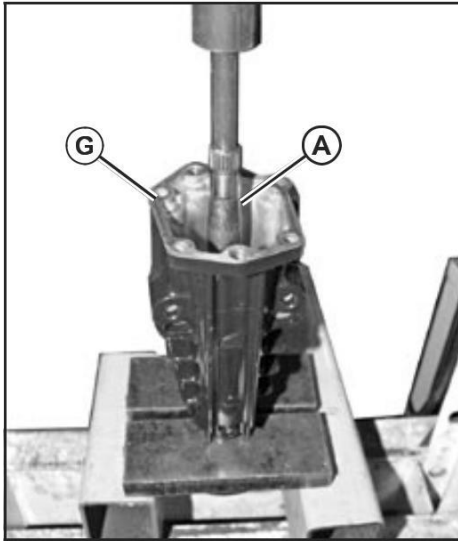

Fig. 75, Rear Axle Disassembly

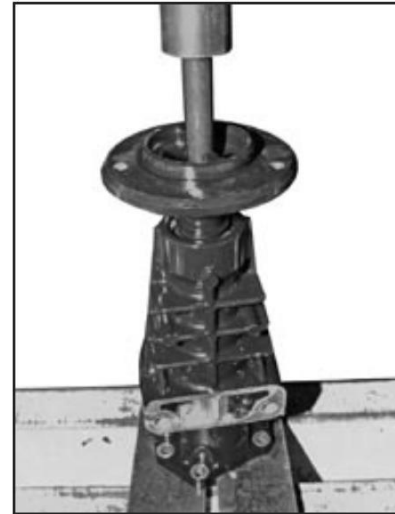

Fig. 76, Rear Axle Assembly

1. Remove large snap ring (B) from groove of axle housing (G). (Fig. 74)
2. Use a press to remove axle shaft (A) from axle housing (G). (Fig. 75)
3. Remove remaining snap ring to remove axle shaft components.
4. Inspect axle shaft and housing for wear or damage. Replace parts as necessary.
5. Inspect bearing for smooth rotation. Replace if necessary.

NOTE: Ball bearing is not pressed into housing. When placed in axle housing it may be loose. A clearance up to 0.38 mm (0.015 in.) is normal.

6. Install bearing, seal and snap ring into axle housing. Put spring-side of seal into housing first.
7. Apply petroleum jelly to lips of seal and inner diameter of sleeve.
8. Install snap ring, washer and sleeve on axle shaft. Use a piece of pipe with a minimum inside diameter of 31 mm (1-3/16 in.) to push sleeve and washer tight against shoulder of shaft.

IMPORTANT: Avoid damage! Do not use excessive force to install axle shaft. Axle housing may be cracked or damaged if too much force is used.

9. Install axle shaft assembly into axle housing using a press. Press shaft only until a rapid increase in pressure is noticed.

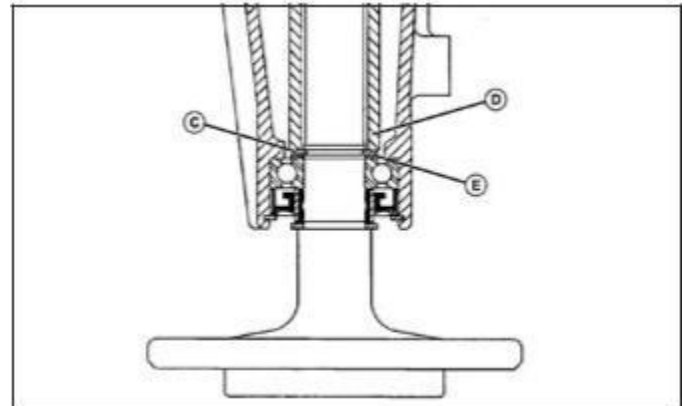

Fig. 77, Rear Axle Cut-away

10. Install washer (E) and snap ring (C) on axle shaft. (Fig. 77)
11. Use a piece of pipe (D) with a minimum inside diameter of 31 mm (1-3/16 in.), maximum outer diameter of 43 mm (1-11/16 in.) and approximately 330 mm (13 in.) long to install snap ring.

IMPORTANT: Avoid damage! Do not use excessive force to install axle shaft. Axle housing may be cracked or damaged if too much force is used.

Tuff Torq K92 Hydrostatic Transaxle

Brakes Removal and Installation

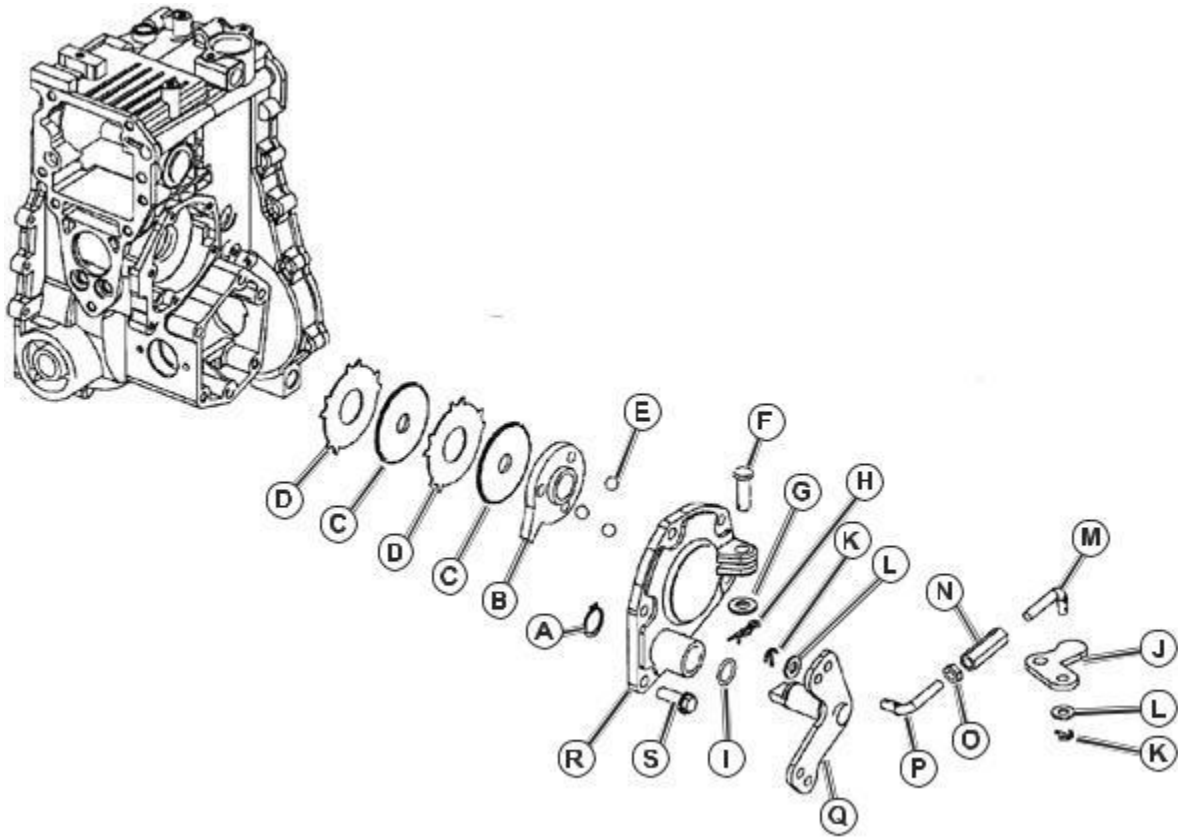

Fig. 78, Brake Disassembly

- A - Snap Ring
- B - Brake Actuator Plate
- C - Friction Plate
- D - Steel Plate
- E - Steel Ball
- F - Clevis Pin
- G - Washer
- H - Spring Lock Pin
- I - O-ring
- J - Interlock Plate
- K - Cotter Pin
- L - Washer
- M - Rod
- N - Adjustment Nut
- O - Nut
- P - Rod

- Q - Cam Lever
- R - Brake Cover
- S - Cap Screw

1. Inspect components on brake cover (R). Replace as nec-essary. Apply petroleum jelly to O-ring. (Fig. 78)
2. Inspect plates for wear or spline damage. If groove pattern in friction plates is no longer visible, replace plates.
3. Apply petroleum jelly to balls (E) and install balls in cover.
4. Install steel plates (D) and friction plates (C) alternately beginning with a steel plate.
5. Apply a bead of silicon sealant to brake cover mating surface of transaxle case.
6. Install brake actuator plate (B) and brake cover assembly (R).

Brake Cover Cap Screw Torque Specifications:

Used Transaxle Case	25 N•m (18 lb-ft)
New Transaxle Case	30 N•m (22 lb-ft)

Hydrostatic Flow Diagram Check Points

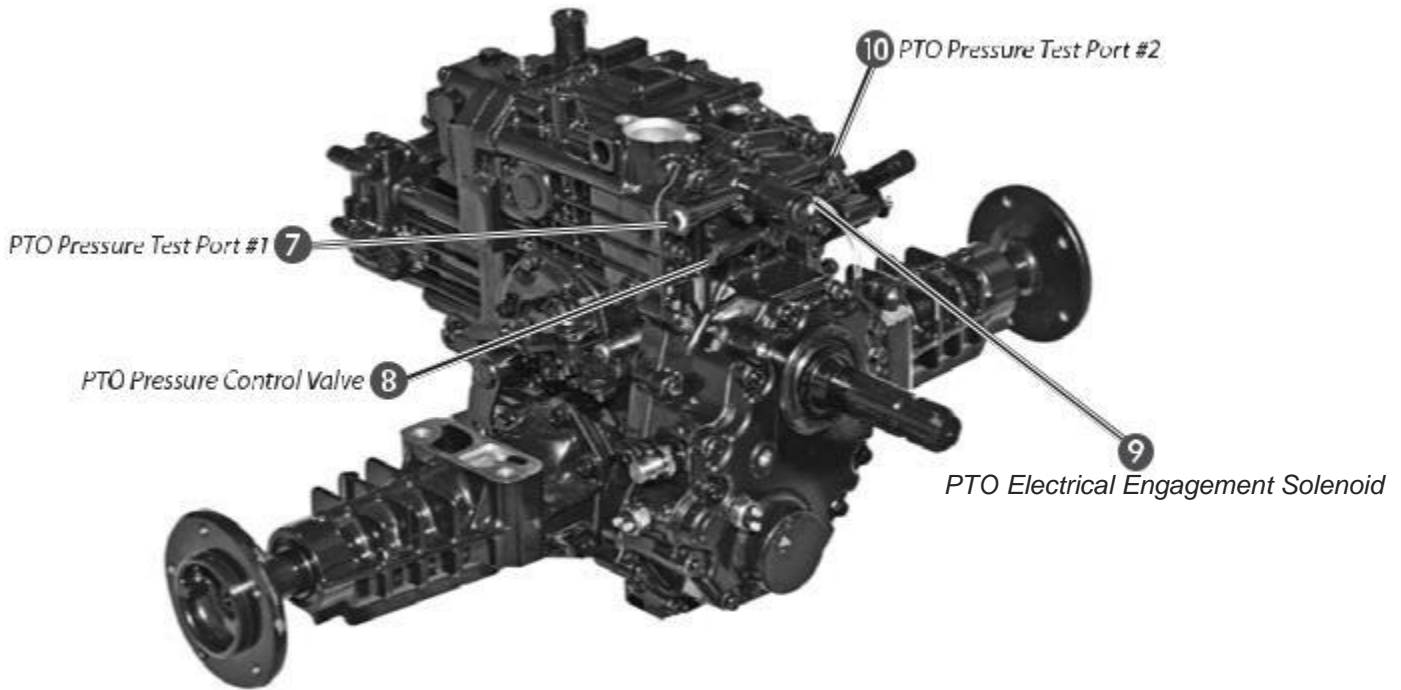

Fig. 79, Check Points Rear PTO

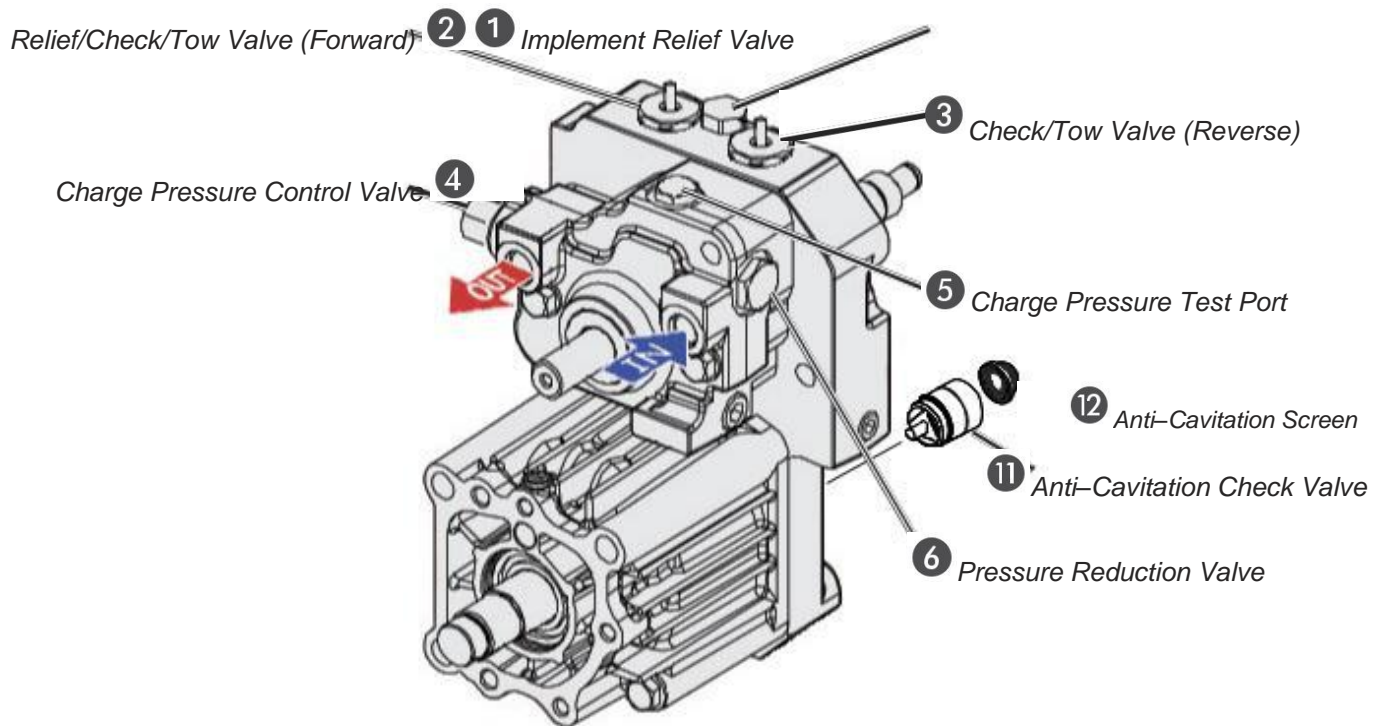
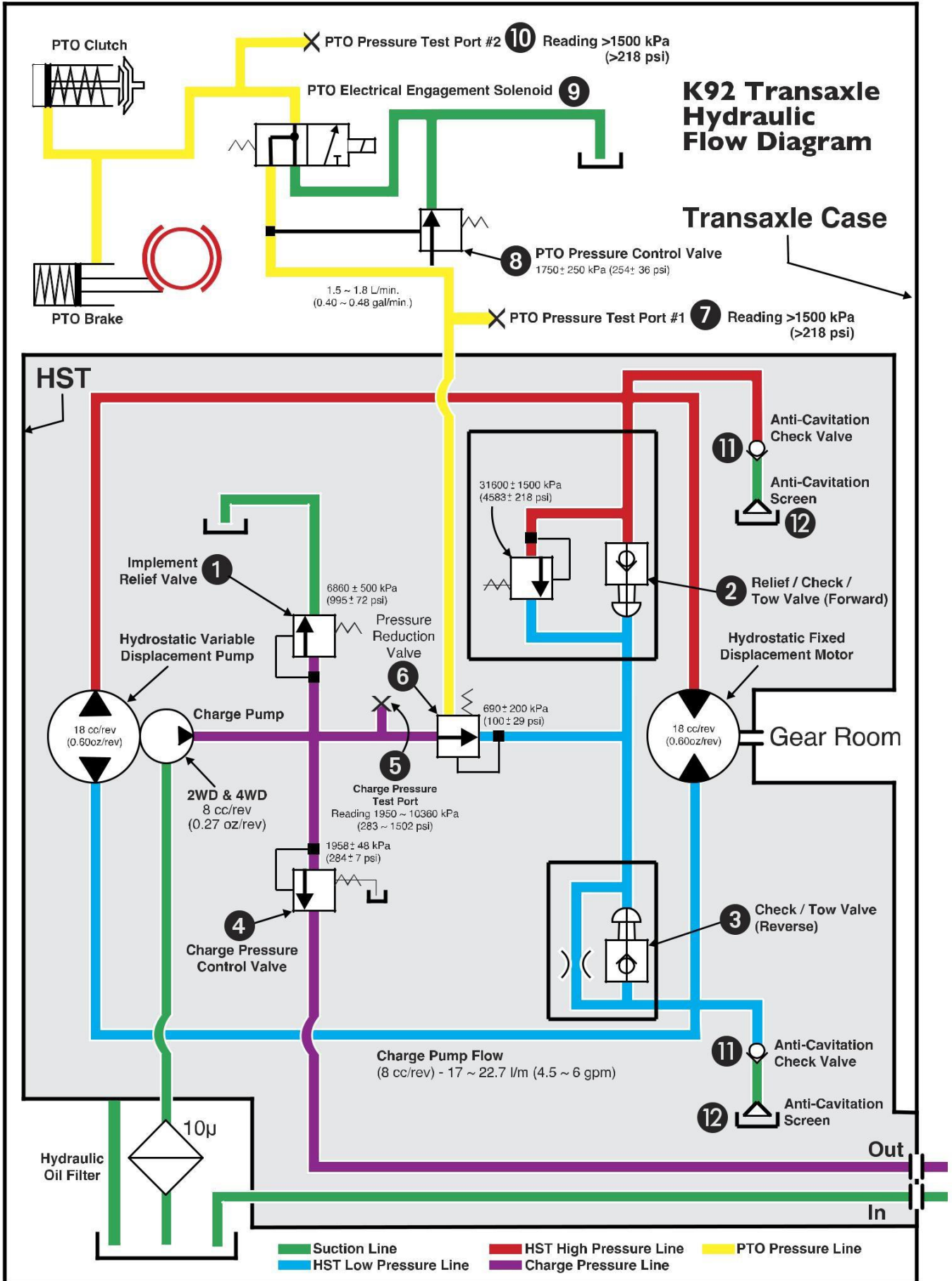

Fig. 80, Check Points Charge Pump/Center Valve



Troubleshooting Guides

Note: If your specific problem and/or solution is not listed below, consult a qualified Tuff Torq Distributor.

Hydrostatic Transmission Problems

Machine will not move on its own power

- ◆ Free-wheeling linkage set for push or partially set
- ◆ Control pedal linkage bent, binding or disconnected
- ◆ Directional control valves leaking or stuck down
- ◆ Brakes set or not releasing
- ◆ Anti-cavitation valves leaking or stuck open
- ◆ Charge pump scored or worn
- ◆ Pump or motor valve plates scored or worn
- ◆ Charge pressure relief valve leaking. Seat valve or spring damaged
- ◆ Drive shaft not turning pump input shaft or charge pump key sheared

Machine will not move—Wheels locked up

- ◆ Brakes set or not releasing

Will not move in one direction

- ◆ Free-wheeling linkage set for push or partially set
- ◆ Control pedal linkage bent, binding or disconnected
- ◆ Directional control valves leaking or stuck down
- ◆ Directional valve in wrong location
- ◆ Anti-cavitation valves leaking or stuck open
- ◆ Pump or motor valve plates scored or worn

Too aggressive in reverse

- ◆ Free-wheeling linkage set for push or partially set
- ◆ Linkage damper (shock absorber) failed
- ◆ Directional control valves leaking or stuck down
- ◆ Pump or motor valve plates scored or worn

Slow forward under load, or speed drops when load is applied

- ◆ Forward pedal height needs to be adjusted
- ◆ Free-wheeling linkage set for push or partially set
- ◆ Control pedal linkage bent, binding or disconnected
- ◆ Directional control valves leaking or stuck down
- ◆ Drive shaft not turning pump input shaft or charge pump key sheared
- ◆ Anti-cavitation valves leaking or stuck open
- ◆ Directional valve in wrong location
- ◆ Charge pump scored or worn
- ◆ Pump or motor valve plates scored or worn
- ◆ Filter plugged or suction side air leak. Check filter, charge pump or case seal
- ◆ Engine performance is poor or not operating or set at correct operating speeds

Erratic speed

- ◆ Free-wheeling linkage set for push or partially set
- ◆ Linkage damper (shock absorber) failed
- ◆ Control pedal linkage bent, binding or disconnected
- ◆ Brakes set or not releasing
- ◆ Directional control valves leaking or stuck down
- ◆ Drive shaft not turning pump input shaft or charge pump key sheared
- ◆ Anti-cavitation valves leaking or stuck open
- ◆ Charge pump scored or worn
- ◆ Pump or motor valve plates scored or worn
- ◆ Filter plugged or suction side air leak. Check filter, charge pump or case seal
- ◆ Charge pressure relief valve leaking. Seat valve or spring damaged
- ◆ Swash plate control shaft or bushing worn
- ◆ Engine performance is poor or not operating or set at correct operating speeds. See Engine diagnosis

Machine will not stop

- ◆ Free-wheeling linkage set for push or partially set
- ◆ Control pedal linkage bent, binding or disconnected
- ◆ Brakes set or not releasing
- ◆ Neutral adjustment is not correct
- ◆ Anti-cavitation valves leaking or stuck open
- ◆ Swash plate control shaft or bushing worn

Transmission operating hot

- ◆ Free-wheeling linkage set for push or partially set
- ◆ Control pedal linkage bent, binding or disconnected
- ◆ Brakes set or not releasing. See Brakes section
- ◆ Neutral adjustment is not correct
- ◆ Oil cooler may be plugged with debris
- ◆ Directional control valves leaking or stuck down
- ◆ Anti-cavitation valves leaking or stuck open
- ◆ Charge pump scored or worn
- ◆ Pump or motor valve plates scored or worn

Hydraulic noise

- ◆ Free-wheeling linkage set for push or partially set
- ◆ Brakes set or not releasing. See Brakes section
- ◆ Neutral adjustment is not correct
- ◆ Drive shaft not turning pump input shaft or charge pump key sheared
- ◆ Directional control valves leaking or stuck down
- ◆ Anti-cavitation valves leaking or stuck open
- ◆ Charge pump scored or worn

Troubleshooting Guides

Hydrostatic Transmission Problems (continued)

Hydraulic noise (continued)

- ◆ Pump or motor valve plates scored or worn
- ◆ Filter plugged or suction side air leak. Check filter, charge pump or case seal
- ◆ Charge pressure relief valve leaking. Seat valve or spring damaged
- ◆ Swash plate control shaft or bushing worn

Gear noise, dependent on speed, direction of travel or during a turn

- ◆ Go through procedures in “Hydrostatic Transmission Test” for additional tests
- ◆ Brakes set or not releasing. See Brakes section
- ◆ Drive shaft not turning pump input shaft or charge pump key sheared
- ◆ Charge pump scored or worn
- ◆ Pump or motor valve plates scored or worn
- ◆ Filter plugged or suction side air leak. Check filter, charge pump or case seal

Mid PTO Engagement Problems

PTO will not engage

- ◆ Check engagement solenoid circuit
- ◆ PTO switch not working
- ◆ PTO lube reduction valve orifice plugged
- ◆ Engagement valve installed incorrectly
- ◆ PTO pressure control valve faulty
- ◆ PTO clutch piston leaking, input shaft seal leaking or clutch disk worn
- ◆ Low charge pump output
- ◆ PTO shaft, gear or bearing failure

Engine stalls when PTO is engaged

- ◆ Excessive load on PTO output. Remove load
- ◆ Use higher engine rpm. Check engine performance
- ◆ Hydraulic circuit in relief. Remove restriction or load
- ◆ PTO brake is not releasing. Check brake piston, O-rings
- ◆ PTO shaft, gear or bearing failure

PTO will not stay engaged

- ◆ Check engagement solenoid circuit
- ◆ Engagement valve installed incorrectly
- ◆ PTO clutch piston leaking, input shaft seal leaking or clutch disk worn

PTO will not stay engaged (continued)

- ◆ Low charge pump output
- ◆ PTO pressure control valve faulty

Gear or bearing noise with PTO engaged

- ◆ PTO brake is not releasing. Check brake piston, O-rings
- ◆ PTO brake springs faulty

PTO shaft slows down

- ◆ Excessive load on PTO output. Remove load
- ◆ Use higher engine rpm. Check engine performance
- ◆ PTO lube reduction valve orifice plugged
- ◆ Low charge pump output
- ◆ PTO pressure control valve faulty
- ◆ PTO clutch piston leaking, input shaft seal leaking or clutch disk worn

PTO Shaft will not stop, or slow to stop

- ◆ Check engagement solenoid circuit
- ◆ Engagement valve installed incorrectly
- ◆ PTO brake is not releasing. Check brake piston, O-rings
- ◆ Excessive load on PTO output. Remove load
- ◆ PTO brake springs faulty

Transaxle Engagement Problems

Hydraulic transmission complaint

- ◆ Brakes are applied or mis-adjusted

Rear drive wheels are locked up; will not move directional pins down

- ◆ Brakes are applied or mis-adjusted
- ◆ Differential lock collar, pin or differential carrier failure
- ◆ Check axle or differential gear failure

Rear wheel free-wheel; no transaxle drive; hydraulic control valve pins are up

- ◆ Check axle or differential gear failure
- ◆ Differential lock collar, pin or differential carrier failure

Troubleshooting Guides

Transaxle Engagement Problems (continued)

Differential lock will not engage

- ◆ Differential lock linkage is mis-adjusted.
- ◆ Differential lock collar, pin or differential carrier fail-ure

Differential lock will not disengage

- ◆ Brakes are applied or mis-adjusted
- ◆ Differential lock linkage is mis-adjusted
- ◆ Differential is engaged. Check adjustment and/or repair differential lock
- ◆ Differential lock collar, pin or differential carrier fail-ure

Transaxle Noise Problems

Ratcheting noise as machine moves

- ◆ Brakes are applied or mis-adjusted
- ◆ Differential lock linkage is mis-adjusted
- ◆ Differential is engaged. Check adjustment and/or repair differential lock
- ◆ Differential lock collar, pin or differential carrier fail-ure
- ◆ Check axle or differential gear failure

Ratcheting noise as machine turns

- ◆ Differential lock linkage is mis-adjusted
- ◆ Differential is engaged. Check adjustment and/or repair differential lock
- ◆ Differential lock collar, pin or differential carrier fail-ure
- ◆ Check axle or differential gear failure